

# MICRO 100<sup>®</sup>

Make More With Micro 100



More Than 600 New  
Turning Tools Inside ▶

Your Source for Fully Stocked Turning Tools



## Make More with Micro 100

### Endurance & Quality

Micro 100 tooling is engineered using the latest CNC grinding technology and manufacturing practices to create the industry's highest quality products.

### Powerful Performance

Micro 100 tooling is designed to excel at vastly increased speed and feed rates while providing exceptional results in a wide array of difficult-to-machine materials.

### Earned Reputation

Micro 100 has built, and earned, an international reputation for manufacturing high quality solid carbide turning tools that are built to last.

Harvey Performance Company combines the leading Harvey Tool, Helical Solutions, Micro 100 brands, and Titan USA to provide world class tooling, unmatched service, and innovative solutions that increase productivity for our customers.



#### Think Harvey Tool First

More than 25,000 miniature and specialty end mills. Ship today, in your machine tomorrow.

[www.harveytool.com](http://www.harveytool.com)



#### Let Helical Impress You

Material-optimized high performance carbide end mills. Run faster, push harder, machine smarter.

[www.helicaltool.com](http://www.helicaltool.com)



#### Make More with Micro 100

Exceptional quality turning tools designed for durability and performance in a range of difficult-to-machine materials.

[www.micro100.com](http://www.micro100.com)



#### Trust in Titan USA

Broad assortment of premium quality, fully stocked, general purpose cutting tools of exceptional value.

[www.titancuttingtools.com](http://www.titancuttingtools.com)

# Our Make More Promise

In today's competitive machining industry, the pressure is high for shops to increase metal removal rates, boost productivity, and improve their bottom line. When "making more" is pivotal, you can count on Micro 100 to help you gain a competitive edge and set your shop up for success. From our expansive tool offering and off-the-shelf availability, to our excellent product quality and highly repeatable Micro-Quik™ Quick Change system, we guarantee you'll Make More with Micro 100 every time you choose us.

**Turning Quick Change**  
pg 11

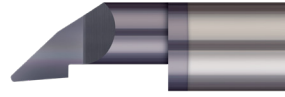

**Turning Standard**  
pg 69

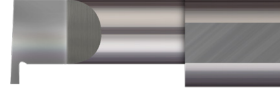

**Milling**  
pg 155



**Holemaking & Threading**  
pg 252



## New Turning Tools & Quickchange Holders

Quick Change Grooving Tools Retaining Ring Corner Radius Right Hand

pg 31



Standard Profiling Tools Axial Profiling

pg 90



Standard Grooving Tools Retaining Ring Square Right Hand Miniature

pg 91

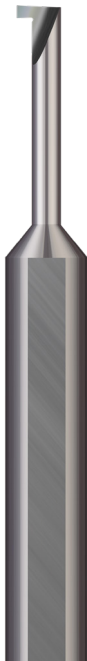

Standard Grooving Tools Retaining Ring Corner Radius Right Hand

pg 99



Quick Change Tool Holders Straight Holder Standard Length

pg 50



Quick Change Tool Holders Straight Holder Long Length

pg 52

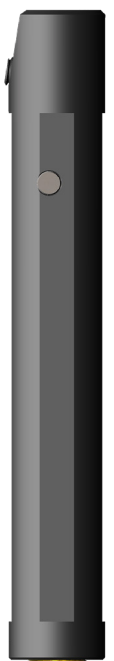

Learn more on pg 10 about Quick Change Tool Holders

# TURNING

Begins on page 11

## Internal Diameter (ID) – Quick Change ..... 12

- Quick Change – Boring Tools ..... 12
  - Right Hand ..... 12
  - Helical Back Rake ..... 17
  - Top Rake Chipbreaker ..... 19
- Boring Head Tools ..... 21
- Reverse Boring ..... 22
- Quick Change – Profiling Tools ..... 23
- Quick Change – Grooving Tools ..... 26
  - Retaining Ring **New Style and Sizes!** ..... 26
  - Full Radius ..... 33
  - Undercutting ..... 36
  - Face Grooving ..... 37
- Quick Change – Threading Tools ..... 42
- Quick Change – Holmaking Tools ..... 45
- Quick Change – Holders & Parts **New Styles and Sizes!** ..... 50



Quick Change Reverse Boring Tools on pg 22



Quick Change Spotting Drills on pg 45



Standard Miniature Boring Tools on pg 69

## Internal Diameter (ID) – Standard ..... 69

- Standard – Boring Tools ..... 69
  - Right Hand ..... 69
  - Left Hand ..... 79
  - Helical Back Rake ..... 82
  - Top Rake Chipbreaker ..... 86
  - Brazed ..... 87
- Standard – Profiling Tools **New Style!** ..... 89
- Standard – Grooving Tools **New Style and Sizes!** ..... 91
  - Retaining Ring ..... 91
  - Full Radius ..... 101
  - Undercutting ..... 103
  - O-Ring Grooving ..... 105
  - Face Grooving ..... 106
- Standard – Threading Tools ..... 111
- Standard – Tool Holders ..... 120

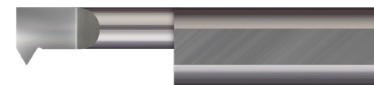

Standard Threading Tools on pg 111

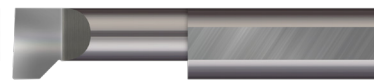

Standard Thread Relief Tools on pg 119

## TURNING (CONT.)

Internal Diameter (ID) – Indexable ..... 122

Outside Diameter (OD) – Indexable ..... 126

Outside Diameter (OD) – Brazed ..... 131

## MILLING

Begins on page 155

End Mills ..... 156

Material Specific End Mills ..... 182

Specialty Profiles ..... 232

Undercutting End Mills ..... 232

Drill / End Mills ..... 234

Chamfer Cutters ..... 236

Runner Cutters ..... 238

Engraving Cutters ..... 239

Keyseat Cutters ..... 243

Corner Rounding End Mills ..... 246

Dovetail Cutters ..... 248

Die Sink Cutters ..... 249

Indexable Milling ..... 250

Holemaking & Threading ..... 252

Drills ..... 252

Combined Drill & Countersinks ..... 255

Thread Milling Cutters ..... 256

## BLANKS, SETS & ACCESSORIES

Begins on page 263

Blanks, Sets & Accessories ..... 263



Brazed Forming Tools 90° Radius  
Concave Left Hand on pg 140

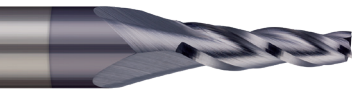

3 Flute Tapered End Mill  
on pg 169

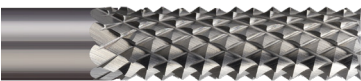

Diamond Cut End Mills for  
Composites on pg 228



Spade Drills on pg 253



Multi-Form Thread Milling  
Cutters on pg 258

## Table of Contents – Tool Number Prefix

Prefix	Page
AECM	179
AELM	164
AEMM	159
AL	132
AMRM	156
AR	132
ARC	216, 223
ARM / ARMM	192, 220
ASM / ASMM	191, 219
BB	75
BB Set	271
BBL	79
BBM	70
BBS	70
BEF / BEFM	196
BEL / BELM	176
BEM / BEMM	170
BL	133
BLR / BLRM	176
BMR / BMRM	170
BMS	170
BMSM	170
BR	133
BT	131
BTL	131
C	134
CL	151
CPG	284
CR	150
CRE	247

Prefix	Page
CREM	246
CRT	135
CS	236
CT	152
D	136
DC / DCM	255
DC Set	282
DM / DMM	234
DR	254
DSC	249
DT	248
E	146
EL	147
EMH / EMHM	195
EMS / EMSM	167
ER	147
FG	106
FGC	108
FGF	110
FR	101
FRT	141
GEC	179
GEL / GELM	164
GEM / GEMM	159
GLR / GLRM	166
GR	142
GR-F	143
GS	144
GS-F	145
HBB / HBM	84

Prefix	Page
HBBC	82
HMCM	182
HR / HRM	264
IAT	116
IDLT	118
IDRT	118
IT	111
IT Set	273
ITL	113
ITM	115
KC	243
LC	149
LT	148
LTR	119
MBB / MBBM	69
MBB Set	270
MBC	237
MEF / MEFM	183, 202
MMBM	176
MMRM	181
MRF	238
MRT	238
MRR <b>NEW!</b>	91
MTR	261
OR	105
PBT	86
PF	90
PR <b>NEW!</b>	89
QBB	13, 15
QBM	21

## Table of Contents – Tool Number Prefix

Prefix	Page
QBT	19
QC	67
QCS	49
QDC	47
QDH	57
QDS / QDSM	57
QFG	37
QFGC	39
QFGF	41
QFR	34
QHBBC	17
QI	64
QIT	42
QMBB	12
QMFR	33
QMRR	26
QPF	24
QPR	23
QRB	22
QRR	28
QRRC <b>NEW!</b>	31
QSD	48
QSG	63
QSP	65
QSPD	45
QSR	66
QTH / QTHM	53
QTHL / QTHML	55
QTS / QTSP <b>NEW!</b>	50
QTSL / QTSP <b>NEW!</b>	52

Prefix	Page
QUP	36
QZST	59,60
RAD	139
RAD Set	275
RAL	140
RAL Set	276
RC	149
RDA	228
RDB	229
RDC	230
RDD	230
RDE	231
RME / RMEM	156
RNC / RNCM	239
RR / RRM	92
RR Set	272
RRC <b>NEW!</b>	99
RRL	97
RS / RSM	268
RSC / RSCM	239
RT	148
RTC / RTCM	239
RXD	137
RXL	138
SAT	117
SBM / SBMM	232
SD	253
SDH / SDHM	189
SEM	159
SFA / SFAM	222

Prefix	Page
SFBM	176
SFL / SFLM	226
SFP / SFPM	224
SHL / SHLM	190
SHR / SHRM	190
SME	156
SPD	252
SPG	284
SR / SRM	265
T	153
TBB / TBBL	87
TBB / TBBL Sets	276
TBBC / TBBCL	88
TD	284
TH / THM / THMA	120
TM	256-259
TMM	260
TP	284
TPG	284
TRG	141
TSM	169
T-V	154
UC	103
UP	104
VHM / VHMM	193,213,217
VHS / VHSM	193,213
VLM	194,214
VLR	194,215,218
VLR / VLRM	215

# Micro 100 Micro-Quik™

Radial and axial repeatability. Tip-to-tip consistency. Part-to-part accuracy.

Micro 100's Micro-Quik™ is a breakthrough tool change system that saves machinists countless hours by allowing for incredibly fast tool changes without sacrificing locational repeatability or machining accuracy. This fool proof system delivers impressive radial and axial repeatability, tip-to-tip consistency, and part-to-part accuracy.

In critical accuracy situations, many customers have enjoyed .0002" tool-to-tool repeatability, achieved in fewer than 30 seconds. This is 90% faster than conventional tool change methods, which oftentimes take in excess of 5 minutes, start-to-finish.

Because of its simplicity and extremely low margin for error, Micro-Quik™ is the preferred tool change method of machine shops worldwide, even those employing new and up-and-coming machinists.

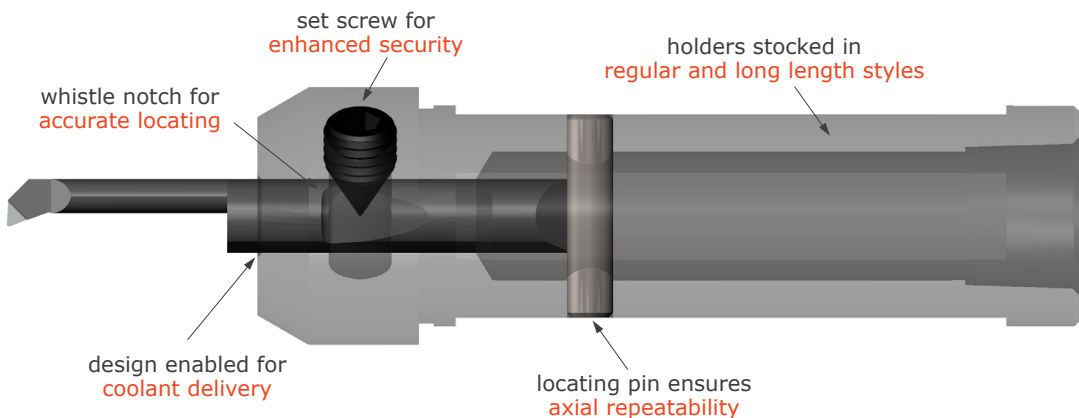

## A Unique Design

Micro 100's Micro-Quik™ features a whistle notch configuration, proven to enhance axial accuracy over the standard set screw design used by other quick change system manufacturers. The whistle notch used by Micro 100 ensures that the tool is always held in location, anchored accurately in place, and pushed completely against the locating mechanism.

This axial consistency prevents all-too-common tool failures, scrap parts, and lost machine time due to improperly secured tools.

## Incredible Benefits

Micro-Quik™ users have long enjoyed the benefits it provides: tool changes in less than 30 seconds, fewer tool change errors, impressive radial and axial repeatability, and increased machine up-time.

Learn which quick change tool holder is best for you on pg 10



## How It Works

During tool changes, the precision ground bevel specially engineered on the rear of each Micro 100 quick change tool aligns with a locating pin in the quick change tool holder. The distance from this locational point to the tip of the tool is highly controlled, meaning that our Micro-Quik™ tooling system ensures a very high degree of tool length and centerline repeatability.

## Easy 3-Step Process

1. Remove the existing tool by loosening the set screw.
2. Remove the used tool.
3. Insert the new tool and retighten the set screw.



**Quick Change Tooling begins on pg 12**

### Vast Holder Offering

- Standard Length Tool Holders
- Long Length Tool Holders
- Double-Ended Tool Holders
- Holders for Star Swiss Machines
- Imperial and Metric Tool Shanks
- Plumbed and Ported Coolant Access Options
- Tool Holders for Grinding Custom Profiles

### Expansive Tool Offering

- Boring Tools
- Axial Profiling Tools
- Radial Profiling Tools
- Top Rake Chipbreakers
- Grooving Tools
- Face Grooving Tools
- Undercutting Tools
- Threading Tools
- Spotting Drills
- Combined Drill & Countersinks
- Spade Drills
- Chamfer Tools

**More Than 1,900 Stocked Quick Change Tools!**

# Quick Change Tool Holders

Begins on pg 50

Our Spring 2021 Product Catalog introduces new headless-style quick change tool holders to Micro 100's offering, rounding out our **fully stocked** selection of best-in-class tool holders that deliver unparalleled speed, repeatability, and accuracy. Our newest quick change holders are engineered for **use in all Swiss, standard lathe, or multi-function lathe machines** and are designed for ease of installation through the back side of the tooling block.

Plumbed & Ported  
QTSP pg 50

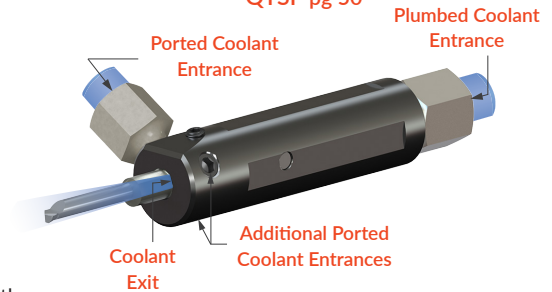

## New Straight Quick Change Tool Holders

- Enhanced application flexibility and headless design
- Optimized for use in any Swiss, standard lathe, or multi-function lathe
- Offered with ported, plumbed, or ported & plumbed coolant access options
- Designed for ease of installation through the back side of the tooling block
- Stocked in standard and long length styles

Choose from 5 time-saving Quick Change holder styles!

Unmatched Speed, Repeatability, & Accuracy

**New!**

Headless tool holders engineered for use in any Swiss, standard, or multi-function lathe machine. Designed for ease of installation through the back side of the tooling block.

See pages 50-52

	Straight Holder Standard Length QTS / QTSP	Straight Holder Long Length QTSL / QTSPL	Headed Holder Standard Length QTH / QTHM	Headed Holder Long Length QTHL / QTHML	Tool Holder System Double Ended Modular QDH / QDS / QDSM
	A reliable go-to for maximum machine compatibility and best-in-class coolant delivery options.		"The Original" holder designed to excel in high axial force operations.		Double-ended for use in twin spindle and Y-axis tooling block locations.
	pages 50-51	page 52	pages 53-54	pages 55-56	pages 57-58
Coolant Access Type	Plumbed & Ported	Plumbed & Ported	Plumbed	Plumbed	Ported
Headless Holder Design for Easy Machine Access	✓	✓			✓
Adjustable Holder Depth in the Block	✓	✓			✓
Can Be Loaded Through Back of Tooling Block for Ease of Use	✓	✓			✓
Headed Design for Repeatable Holder Replacement			✓	✓	
Long Length for Extended Reach Applications		✓		✓	
Modular & Double-Ended for Added Versatility					✓
Set Screw Number/Orientation	1/Top	1/Top	1/Side	1/Side	1/Side

# TURNING

## Internal Diameter & Outside Diameter

### Internal Diameter (ID) – Quick Change ..... 12

Quick Change – Boring Tools .....	12
Quick Change – Profiling Tools .....	23
Quick Change – Grooving Tools <b>New Style and Sizes!</b> .....	26
Quick Change – Threading Tools .....	42
Quick Change – Holmaking Tools .....	45
Quick Change – Holders & Parts <b>New Styles and Sizes!</b> .....	50

### Internal Diameter (ID) – Standard ..... 69

Standard – Boring Tools .....	69
Standard – Profiling Tools <b>New Style!</b> .....	89
Standard – Grooving Tools <b>New Style and Sizes!</b> .....	91
Standard – Threading Tools .....	111
Standard – Tool Holders .....	120

### Internal Diameter (ID) – Indexable ..... 122

Indexable – Boring Bars, Boring .....	122
Indexable – Boring Bars, Facing .....	124
Indexable – Boring Bars, Profiling .....	125

### Outside Diameter (OD) – Indexable ..... 126

Indexable – Tool Holders, Chamfering & Turning .....	126
Indexable – Tool Holders, Facing & Turning .....	127
Indexable – Tool Holders, Profiling .....	130

### Outside Diameter (OD) – Brazed ..... 131

Brazed – Box Turning Tools .....	131
Brazed – Forming Tools .....	132
Brazed – Grooving Tools .....	141
Brazed – Threading Tools .....	146
Brazed – Screw Machining Tools .....	148
Brazed – Cut Off Tools .....	150

# Quick Change – Boring Tools

QMBB

Right Hand – Sharp – Miniature

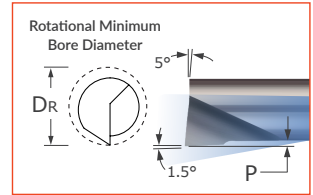
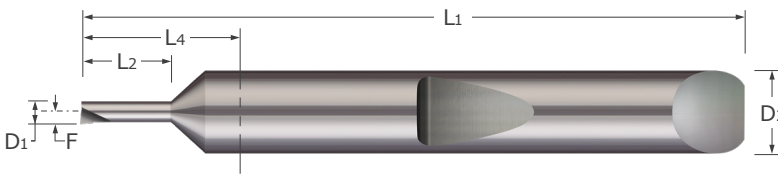

Quick Change – Boring Tools

- Designed for facing and boring applications in bores .015" and larger
- Polished split face for improved edge retention and chip evacuation while reducing galling
- Split geometry makes the tool as rigid as possible
- On center neck design allows for static (D<sub>1</sub>) and live/rotating (D<sub>R</sub>) applications
- Coolant fed enabled shank design
- Sharp corner profile
- Proprietary Micro-Quik™ quick change system maximizes productivity through reliable accuracy and locational repeatability
- AlTiN coated option provides added lubricity and increased wear resistance in difficult to machine materials
- Solid carbide
- CNC ground in the USA

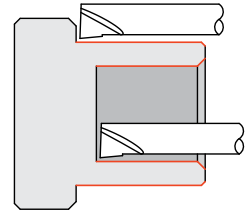

Minimum Bore Diameter	Rotational Minimum Bore Diameter	Maximum Bore Depth	Projection	Length From Holder	Centerline Offset	Shank Diameter	Overall Length	Uncoated		AlTiN Coated	
								Tool #	Price	Tool #	Price
D <sub>1</sub>	D <sub>R</sub>	L <sub>2</sub> <sup>+0.030"</sup> / <sub>-.000"</sub>	P	L <sub>4</sub>	F	D <sub>2</sub> (h6)	L <sub>1</sub>				
.0135	.0150	.050	.0015	.590	.0075	.1875	1.5	QMBB-015050	42.30	QMBB-015050X	44.20
.0180	.0200	.075	.0020	.590	.0100	.1875	1.5	QMBB-020075	42.30	QMBB-020075X	44.20
.0225	.0250	.100	.0025	.590	.0125	.1875	1.5	QMBB-025100	37.25	QMBB-025100X	39.15
.0270	.0300	.100	.0030	.590	.0150	.1875	1.5	QMBB-030100	37.25	QMBB-030100X	39.15
.0315	.0350	.100	.0035	.590	.0175	.1875	1.5	QMBB-035100	37.25	QMBB-035100X	39.15
.0315	.0350	.150	.0035	.590	.0175	.1875	1.5	QMBB-035150	37.25	QMBB-035150X	39.15
.0360	.0400	.150	.0040	.590	.0200	.1875	1.5	QMBB-040150	37.25	QMBB-040150X	39.15
.0360	.0400	.200	.0040	.590	.0200	.1875	1.5	QMBB-040200	37.25	QMBB-040200X	39.15
.0405	.0450	.150	.0045	.590	.0225	.1875	1.5	QMBB-045150	37.25	QMBB-045150X	39.15
.0405	.0450	.200	.0045	.590	.0225	.1875	1.5	QMBB-045200	37.25	QMBB-045200X	39.15
.0440	.0500	.150	.0060	.590	.0250	.1875	1.5	QMBB-050150	29.15	QMBB-050150X	31.05
.0440	.0500	.200	.0060	.590	.0250	.1875	1.5	QMBB-050200	29.15	QMBB-050200X	31.05
.0440	.0500	.300	.0060	.590	.0250	.1875	1.5	QMBB-050300	29.15	QMBB-050300X	31.05
.0525	.0600	.150	.0075	.590	.0300	.1875	1.5	QMBB-060150	29.15	QMBB-060150X	31.05
.0525	.0600	.200	.0075	.590	.0300	.1875	1.5	QMBB-060200	29.15	QMBB-060200X	31.05
.0525	.0600	.300	.0075	.590	.0300	.1875	1.5	QMBB-060300	29.15	QMBB-060300X	31.05
.0525	.0600	.400	.0075	.590	.0300	.1875	1.5	QMBB-060400	29.15	QMBB-060400X	31.05
.0525	.0600	.500	.0075	.590	.0300	.1875	1.5	QMBB-060500	29.15	QMBB-060500X	31.05
.0625	.0700	.150	.0075	.590	.0350	.1875	1.5	QMBB-070150	29.15	QMBB-070150X	31.05
.0625	.0700	.200	.0075	.590	.0350	.1875	1.5	QMBB-070200	29.15	QMBB-070200X	31.05
.0625	.0700	.300	.0075	.590	.0350	.1875	1.5	QMBB-070300	29.15	QMBB-070300X	31.05
.0625	.0700	.400	.0075	.590	.0350	.1875	1.5	QMBB-070400	29.15	QMBB-070400X	31.05
.0625	.0700	.500	.0075	.590	.0350	.1875	1.5	QMBB-070500	29.15	QMBB-070500X	31.05
.0700	.0800	.150	.0100	.590	.0400	.1875	1.5	QMBB-080150	29.15	QMBB-080150X	31.05
.0700	.0800	.200	.0100	.590	.0400	.1875	1.5	QMBB-080200	29.15	QMBB-080200X	31.05
.0700	.0800	.300	.0100	.590	.0400	.1875	1.5	QMBB-080300	29.15	QMBB-080300X	31.05
.0700	.0800	.500	.0100	.590	.0400	.1875	1.5	QMBB-080500	29.15	QMBB-080500X	31.05
.0700	.0800	.600	.0100	1.090	.0400	.1875	2.0	QMBB-080600	29.15	QMBB-080600X	31.05
.0800	.0900	.300	.0100	.590	.0450	.1875	1.5	QMBB-090300	29.15	QMBB-090300X	31.05
.0800	.0900	.500	.0100	.590	.0450	.1875	1.5	QMBB-090500	29.15	QMBB-090500X	31.05
.0800	.0900	.700	.0100	1.090	.0450	.1875	2.0	QMBB-090700	29.15	QMBB-090700X	31.05
.0875	.1000	.300	.0125	.590	.0500	.1875	1.5	QMBB-100300	29.15	QMBB-100300X	31.05
.0875	.1000	.500	.0125	.590	.0500	.1875	1.5	QMBB-100500	29.15	QMBB-100500X	31.05
.0875	.1000	.700	.0125	1.090	.0500	.1875	2.0	QMBB-100700	29.15	QMBB-100700X	31.05
.0875	.1000	.800	.0125	1.090	.0500	.1875	2.0	QMBB-100800	29.15	QMBB-100800X	31.05

See pg 50-62 for quick change holder options

## QBB

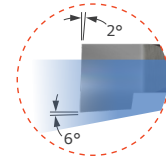
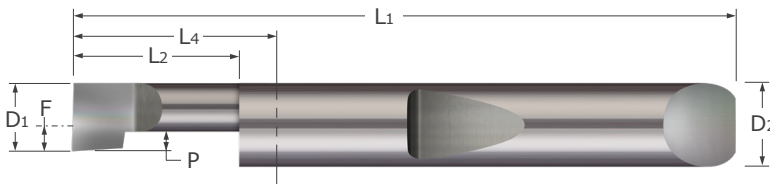
Quick Change – Boring Tools  
Right Hand – Sharp

- Designed for facing and boring applications in bores .050" and larger
- Polished split face for improved edge retention and chip evacuation while reducing galling
- Split geometry makes the tool as rigid as possible
- Coolant fed enabled shank design
- Sharp corner profile
- Proprietary Micro-Quik™ quick change system maximizes productivity through reliable accuracy and locational repeatability
- AlTiN coated option provides added lubricity and increased wear resistance in difficult to machine materials
- Solid carbide ■ CNC ground in the USA

## Coolant Groove Style

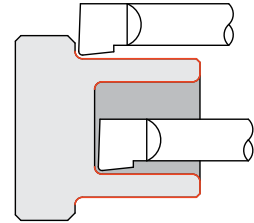
QBB-050s  
thru 120s

Minimum Bore Diameter D1	Maximum Bore Depth L2 $\begin{matrix} +.030'' \\ -.000'' \end{matrix}$	Projection P	Length From Holder L4	Centerline Offset F	Shank Diameter D2 (h6)	Overall Length L1	Uncoated		AlTiN Coated	
							Tool #	Price	Tool #	Price
.0500	.150	.013	.590	-.043	.1875	1.5	QBB-050150	29.15	QBB-050150X	31.05
.0500	.200	.013	.590	-.043	.1875	1.5	QBB-050200	29.15	QBB-050200X	31.05
.0500	.300	.013	.590	-.043	.1875	1.5	QBB-050300	29.15	QBB-050300X	31.05
.0500	.400	.013	.590	-.043	.1875	1.5	QBB-050400	29.15	QBB-050400X	31.05
.0600	.150	.015	.590	-.033	.1875	1.5	QBB-060150	29.15	QBB-060150X	31.05
.0600	.200	.015	.590	-.033	.1875	1.5	QBB-060200	29.15	QBB-060200X	31.05
.0600	.300	.015	.590	-.033	.1875	1.5	QBB-060300	29.15	QBB-060300X	31.05
.0600	.400	.015	.590	-.033	.1875	1.5	QBB-060400	29.15	QBB-060400X	31.05
.0600	.500	.015	.590	-.033	.1875	1.5	QBB-060500	29.15	QBB-060500X	31.05
.0800	.200	.020	.590	-.013	.1875	1.5	QBB-080200	29.15	QBB-080200X	31.05
.0800	.300	.020	.590	-.013	.1875	1.5	QBB-080300	29.15	QBB-080300X	31.05
.0800	.500	.020	.590	-.013	.1875	1.5	QBB-080500	29.15	QBB-080500X	31.05
.0800	.600	.020	1.090	-.013	.1875	2.0	QBB-080600	29.15	QBB-080600X	31.05
.1000	.200	.025	.590	.006	.1875	1.5	QBB-100200	30.85	QBB-100200X	32.75
.1000	.300	.025	.590	.006	.1875	1.5	QBB-100300	30.85	QBB-100300X	32.75
.1000	.500	.025	.590	.006	.1875	1.5	QBB-100500	30.85	QBB-100500X	32.75
.1000	.700	.025	1.090	.006	.1875	2.0	QBB-100700	30.85	QBB-100700X	32.75
.1100	.300	.028	.590	.016	.1875	1.5	QBB-110300-000	30.85	QBB-110300-000X	33.75
.1200	.250	.030	.590	.026	.1875	1.5	QBB-120250-000	30.85	QBB-120250-000X	33.75
.1200	.350	.030	.590	.026	.1875	1.5	QBB-120350-000	30.85	QBB-120350-000X	33.75
.1200	.500	.030	.590	.026	.1875	1.5	QBB-120500-000	30.85	QBB-120500-000X	33.75
.1200	.800	.030	1.090	.026	.1875	2.0	QBB-120800-000	30.85	QBB-120800-000X	33.75

Continued on next page

See pg 50-62 for quick change holder options

See pg 12 for miniature sizes

For better chip control and freer cutting action, see Helical Back Rake and Top Rake Chipbreaker tools on pgs 17-20

# Quick Change – Boring Tools

## Right Hand – Sharp (cont.)

**QBB**

Continued from previous page

Minimum Bore Diameter	Maximum Bore Depth	Projection	Length From Holder	Centerline Offset	Shank Diameter	Overall Length	Uncoated		AlTiN Coated	
D1	L2 <sup>+0.030"</sup> <sub>-.000"</sub>	P	L4	F	D2 (h6)	L1	Tool #	Price	Tool #	Price
.1400	.250	.035	.590	.046	.1875	1.5	QBB-140250-000	30.85	QBB-140250-000X	33.75
.1400	.400	.035	.590	.046	.1875	1.5	QBB-140400-000	30.85	QBB-140400-000X	33.75
.1400	.500	.035	.590	.046	.1875	1.5	QBB-140500-000	30.85	QBB-140500-000X	33.75
.1400	.800	.035	1.090	.046	.1875	2.0	QBB-140800-000	30.85	QBB-140800-000X	33.75
.1600	.400	.040	.590	.066	.1875	1.5	QBB-160400-000	30.85	QBB-160400-000X	33.75
.1600	.500	.040	.590	.066	.1875	1.5	QBB-160500-000	30.85	QBB-160500-000X	33.75
.1600	.600	.040	1.090	.066	.1875	2.0	QBB-160600-000	30.85	QBB-160600-000X	33.75
.1600	1.000	.040	1.090	.066	.1875	2.0	QBB-1601000-000	30.85	QBB-1601000-000X	33.75
.1800	.350	.045	.853	.055	.2500	2.0	QBB-180350-000	34.60	QBB-180350-000X	39.50
.1800	.500	.045	.853	.055	.2500	2.0	QBB-180500-000	34.60	QBB-180500-000X	39.50
.1800	.600	.045	.853	.055	.2500	2.0	QBB-180600-000	34.60	QBB-180600-000X	39.50
.1800	.750	.045	.853	.055	.2500	2.0	QBB-180750-000	34.60	QBB-180750-000X	39.50
.2000	.400	.050	.853	.075	.2500	2.0	QBB-200400-000	34.60	QBB-200400-000X	39.50
.2000	.500	.050	.853	.075	.2500	2.0	QBB-200500-000	34.60	QBB-200500-000X	39.50
.2000	.750	.050	.853	.075	.2500	2.0	QBB-200750-000	34.60	QBB-200750-000X	39.50
.2000	1.000	.050	1.353	.075	.2500	2.5	QBB-2001000-000	34.60	QBB-2001000-000X	39.50
.2300	.500	.058	.853	.073	.3125	2.0	QBB-230500-000	44.40	QBB-230500-000X	51.20
.2300	.750	.058	.853	.073	.3125	2.0	QBB-230750-000	44.40	QBB-230750-000X	51.20
.2300	1.000	.058	1.353	.073	.3125	2.5	QBB-2301000-000	44.40	QBB-2301000-000X	51.20
.2300	1.500	.058	1.853	.073	.3125	3.0	QBB-2301500-000	44.40	QBB-2301500-000X	51.20
.2900	.750	.073	.853	.133	.3125	2.0	QBB-290750-000	44.40	QBB-290750-000X	51.20
.2900	1.000	.073	1.353	.133	.3125	2.5	QBB-2901000-000	44.40	QBB-2901000-000X	51.20

See pg 50-62 for quick change holder options

See pg 12 for miniature sizes

For better chip control and freer cutting action, see Helical Back Rake and Top Rake Chipbreaker tools on pgs 17-20

Quick Change – Boring Tools

QBB

Quick Change – Boring Tools  
Right Hand

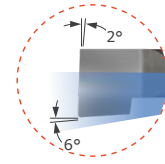
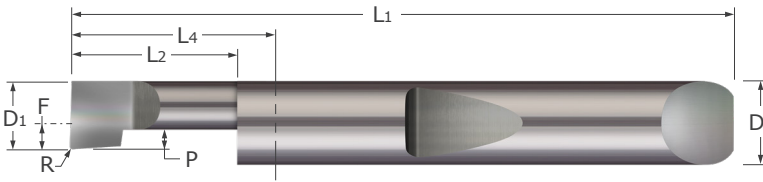

- Designed for facing and boring applications in bores .110" and larger
- Polished split face for improved edge retention and chip evacuation while reducing galling
- Split geometry makes the tool as rigid as possible
- Coolant fed enabled shank design
- Corner radius profile
- Proprietary Micro-Quik™ quick change system maximizes productivity through reliable accuracy and locational repeatability
- AlTiN coated option provides added lubricity and increased wear resistance in difficult to machine materials
- Solid carbide ■ CNC ground in the USA

Coolant Groove Styles

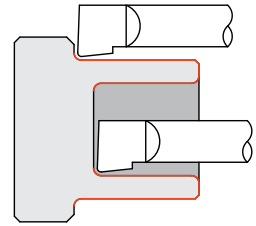

Quick Change – Boring Tools

Min. Bore Diameter	Max. Bore Depth	Radius	Projection	Length From Holder	Centerline Offset	Shank Diameter	Overall Length	Uncoated		AlTiN Coated	
D1	L2 <sup>+ .030"</sup> <sub>- .000"</sub>	R <sup>+ .003"</sup> <sub>- .000"</sub>	P	L4	F	D2 (h6)	L1	Tool #	Price	Tool #	Price
.1100	.300	.003	.028	.590	.016	.1875	1.5	QBB-110300	30.85	QBB-110300X	32.75
.1100	.500	.003	.028	.590	.016	.1875	1.5	QBB-110500	30.85	QBB-110500X	32.75
.1100	.700	.003	.028	1.090	.016	.1875	2.0	QBB-110700	30.85	QBB-110700X	32.75
.1200	.250	.003	.030	.590	.026	.1875	1.5	QBB-120250	30.85	QBB-120250X	32.75
.1200	.350	.003	.030	.590	.026	.1875	1.5	QBB-120350	30.85	QBB-120350X	32.75
.1200	.500	.003	.030	.590	.026	.1875	1.5	QBB-120500	30.85	QBB-120500X	32.75
.1200	.700	.003	.030	1.090	.026	.1875	2.0	QBB-120700	30.85	QBB-120700X	32.75
.1200	.800	.003	.030	1.090	.026	.1875	2.0	QBB-120800	30.85	QBB-120800X	32.75
.1400	.400	.003	.035	.590	.046	.1875	1.5	QBB-140400	30.85	QBB-140400X	32.75
.1400	.600	.003	.035	1.090	.046	.1875	2.0	QBB-140600	30.85	QBB-140600X	32.75
.1400	.800	.003	.035	1.090	.046	.1875	2.0	QBB-140800	30.85	QBB-140800X	32.75
.1600	.400	.003	.040	.590	.066	.1875	1.5	QBB-160400	30.85	QBB-160400X	32.75
.1600	.600	.003	.040	1.090	.066	.1875	2.0	QBB-160600	30.85	QBB-160600X	32.75
.1600	.750	.003	.040	1.090	.066	.1875	2.0	QBB-160750	30.85	QBB-160750X	32.75
.1600	1.000	.003	.040	1.090	.066	.1875	2.0	QBB-1601000	30.85	QBB-1601000X	32.75
.1800	.500	.005	.045	.853	.055	.2500	2.0	QBB-180500	33.30	QBB-180500X	37.20
.1800	.750	.005	.045	.853	.055	.2500	2.0	QBB-180750	33.30	QBB-180750X	37.20
.1800	1.000	.005	.045	1.353	.055	.2500	2.5	QBB-1801000	33.30	QBB-1801000X	37.20
.1800	1.250	.005	.045	1.353	.055	.2500	2.5	QBB-1801250	33.30	QBB-1801250X	37.20
.1800	1.500	.005	.045	1.853	.055	.2500	3.0	QBB-1801500	39.10	QBB-1801500X	43.00
.2000	.500	.005	.050	.853	.075	.2500	2.0	QBB-200500	33.30	QBB-200500X	37.20
.2000	.750	.005	.050	.853	.075	.2500	2.0	QBB-200750	33.30	QBB-200750X	37.20
.2000	1.000	.005	.050	1.353	.075	.2500	2.5	QBB-2001000	33.30	QBB-2001000X	37.20
.2000	1.200	.005	.050	1.353	.075	.2500	2.5	QBB-2001200	33.30	QBB-2001200X	37.20
.2000	1.500	.005	.050	1.853	.075	.2500	3.0	QBB-2001500	39.10	QBB-2001500X	43.00
.2300	.500	.005	.058	.853	.073	.3125	2.0	QBB-230500	44.70	QBB-230500X	48.90
.2300	.750	.005	.058	.853	.073	.3125	2.0	QBB-230750	44.70	QBB-230750X	48.90
.2300	1.000	.005	.058	1.353	.073	.3125	2.5	QBB-2301000	44.70	QBB-2301000X	50.50

See pg 50-62 for quick change holder options

Continued on next page

See pg 12 for miniature sizes

For better chip control and freer cutting action, see Helical Back Rake and Top Rake Chipbreaker tools on pgs 17-20

# Quick Change – Boring Tools

**QBB**

Right Hand (cont.)

Continued from previous page

Quick Change – Boring Tools

Min. Bore Diameter	Max. Bore Depth	Radius	Projection	Length From Holder	Centerline Offset	Shank Diameter	Overall Length	Uncoated		AlTiN Coated	
D1	L2 $\begin{matrix} +.030" \\ -.000" \end{matrix}$	R $\begin{matrix} +.003" \\ -.000" \end{matrix}$	P	L4	F	D2 (h6)	L1	Tool #	Price	Tool #	Price
.2300	1.250	.005	.058	1.353	.073	.3125	2.5	QBB-2301250	44.70	QBB-2301250X	50.50
.2300	1.500	.005	.058	1.853	.073	.3125	3.0	QBB-2301500	51.40	QBB-2301500X	57.20
.2300	1.600	.005	.058	1.853	.073	.3125	3.0	QBB-2301600	51.40	QBB-2301600X	57.20
.2900	.500	.005	.073	.853	.133	.3125	2.0	QBB-290500	44.70	QBB-290500X	48.90
.2900	.750	.005	.073	.853	.133	.3125	2.0	QBB-290750	44.70	QBB-290750X	48.90
.2900	1.000	.005	.073	1.353	.133	.3125	2.5	QBB-2901000	44.70	QBB-2901000X	50.50
.2900	1.250	.005	.073	1.353	.133	.3125	2.5	QBB-2901250	44.70	QBB-2901250X	50.50
.2900	1.500	.005	.073	1.853	.133	.3125	3.0	QBB-2901500	51.40	QBB-2901500X	57.20
.2900	1.750	.005	.073	1.853	.133	.3125	3.0	QBB-2901750	51.40	QBB-2901750X	57.20
.3200	.500	.005	.080	.853	.132	.3750	2.0	QBB-320500	60.95	QBB-320500X	65.15
.3200	.750	.005	.080	.853	.132	.3750	2.0	QBB-320750	60.95	QBB-320750X	65.15
.3200	1.000	.005	.080	1.353	.132	.3750	2.5	QBB-3201000	60.95	QBB-3201000X	66.75
.3200	1.250	.005	.080	1.353	.132	.3750	2.5	QBB-3201250	60.95	QBB-3201250X	66.75
.3200	1.500	.005	.080	1.853	.132	.3750	3.0	QBB-3201500	67.75	QBB-3201500X	73.55
.3200	1.800	.005	.080	1.853	.132	.3750	3.0	QBB-3201800	67.75	QBB-3201800X	73.55
.3200	2.000	.005	.080	2.353	.132	.3750	3.5	QBB-3202000	73.80	QBB-3202000X	81.25
.3200	2.500	.005	.080	2.853	.132	.3750	4.0	QBB-3202500	77.95	QBB-3202500X	85.40
.3600	.750	.005	.090	.853	.172	.3750	2.0	QBB-360750	60.95	QBB-360750X	65.15
.3600	1.000	.005	.090	1.353	.172	.3750	2.5	QBB-3601000	60.95	QBB-3601000X	66.75
.3600	1.250	.005	.090	1.353	.172	.3750	2.5	QBB-3601250	60.95	QBB-3601250X	66.75
.3600	1.500	.005	.090	1.853	.172	.3750	3.0	QBB-3601500	67.75	QBB-3601500X	73.55
.3600	1.800	.005	.090	1.853	.172	.3750	3.0	QBB-3601800	67.75	QBB-3601800X	73.55
.3600	2.000	.005	.090	2.353	.172	.3750	3.5	QBB-3602000	73.80	QBB-3602000X	81.25
.3600	2.500	.005	.090	2.853	.172	.3750	4.0	QBB-3602500	77.95	QBB-3602500X	85.40
.4600	1.000	.005	.115	1.040	.210	.5000	2.5	QBB-4601000	84.90	QBB-4601000X	92.05
.4600	1.250	.005	.115	1.540	.210	.5000	3.0	QBB-4601250	84.90	QBB-4601250X	92.05
.4600	1.500	.005	.115	1.540	.210	.5000	3.0	QBB-4601500	84.90	QBB-4601500X	92.05
.4600	2.000	.005	.115	2.040	.210	.5000	3.5	QBB-4602000	93.15	QBB-4602000X	102.45
.4600	2.500	.005	.115	2.540	.210	.5000	4.0	QBB-4602500	98.60	QBB-4602500X	107.90
.4600	3.000	.005	.115	3.040	.210	.5000	4.5	QBB-4603000	103.30	QBB-4603000X	114.35
.4900	1.000	.005	.123	1.040	.240	.5000	2.5	QBB-4901000	84.90	QBB-4901000X	92.05
.4900	1.250	.005	.123	1.540	.240	.5000	3.0	QBB-4901250	84.90	QBB-4901250X	92.05
.4900	1.500	.005	.123	1.540	.240	.5000	3.0	QBB-4901500	84.90	QBB-4901500X	92.05
.4900	2.000	.005	.123	2.040	.240	.5000	3.5	QBB-4902000	93.15	QBB-4902000X	102.45
.4900	2.500	.005	.123	2.540	.240	.5000	4.0	QBB-4902500	98.60	QBB-4902500X	107.90
.4900	3.000	.005	.123	3.040	.240	.5000	4.5	QBB-4903000	103.30	QBB-4903000X	114.35

See pg 50-62 for quick change holder options

See pg 12 for miniature sizes

For better chip control and freer cutting action, see Helical Back Rake and Top Rake Chipbreaker tools on pgs 17-20



**QHBBC**

**Quick Change – Boring Tools**  
Helical Back Rake – Corner Radius

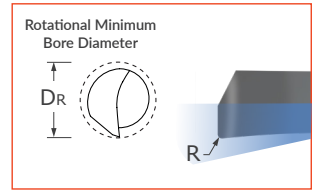
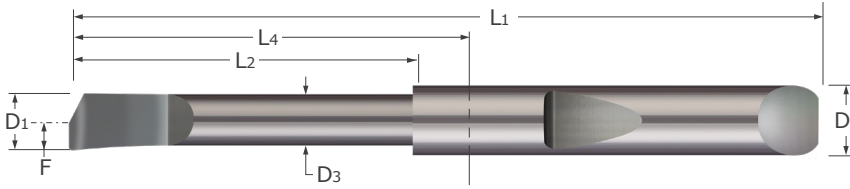

- Designed for boring applications in bores .0275" and larger
- Polished face for improved edge retention and chip evacuation while reducing galling
- Helical grind provides ideal top rake for better chip control and freer cutting
- Well suited for machining plastics
- On center neck design allows for static (D<sub>1</sub>) and live/rotating (D<sub>r</sub>) applications
- Coolant fed enabled shank design
- Corner radius profile
- Proprietary Micro-Quik™ quick change system maximizes productivity through reliable accuracy and locational repeatability
- Solid carbide ■ CNC ground in the USA

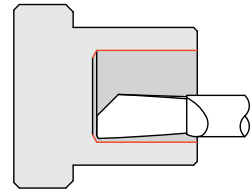

Quick Change – Boring Tools

Minimum Bore Diameter	Rotational Minimum Bore Diameter	Maximum Bore Depth	Radius	Neck Diameter	Length From Holder	Centerline Offset	Shank Diameter	Overall Length	Uncoated	
D <sub>1</sub>	D <sub>r</sub>	L <sub>2</sub> <sup>+ .050"</sup> <sub>- .000"</sub>	R <sup>+ .003"</sup> <sub>- .000"</sub>	D <sub>3</sub> <sup>+ .000"</sup> <sub>- .002"</sub>	L <sub>4</sub>	F	D <sub>2</sub> (h6)	L <sub>1</sub>	Tool #	Price
.0275	.030	.187	.004	.025	.590	.015	.1875	1.5	QHBBC-030187-004	30.90
.0275	.030	.250	.004	.025	.590	.015	.1875	1.5	QHBBC-030250-004	30.90
.0325	.035	.125	.004	.030	.590	.018	.1875	1.5	QHBBC-035125-004	30.90
.0325	.035	.187	.004	.030	.590	.018	.1875	1.5	QHBBC-035187-004	30.90
.0325	.035	.250	.004	.030	.590	.018	.1875	1.5	QHBBC-035250-004	30.90
.0375	.040	.187	.004	.035	.590	.020	.1875	1.5	QHBBC-040187-004	30.90
.0375	.040	.250	.004	.035	.590	.020	.1875	1.5	QHBBC-040250-004	30.90
.0375	.040	.312	.004	.035	.590	.020	.1875	1.5	QHBBC-040312-004	30.90
.0450	.050	.187	.004	.040	.590	.025	.1875	1.5	QHBBC-050187-004	30.90
.0450	.050	.312	.004	.040	.590	.025	.1875	1.5	QHBBC-050312-004	30.90
.0450	.050	.375	.004	.040	.590	.025	.1875	1.5	QHBBC-050375-004	30.90
.0550	.060	.250	.004	.050	.590	.030	.1875	1.5	QHBBC-060250-004	30.90
.0550	.060	.375	.004	.050	.590	.030	.1875	1.5	QHBBC-060375-004	30.90
.0550	.060	.500	.004	.050	.590	.030	.1875	1.5	QHBBC-060500-004	30.90
.0650	.070	.312	.004	.060	.590	.035	.1875	1.5	QHBBC-070312-004	30.90
.0650	.070	.437	.004	.060	.590	.035	.1875	1.5	QHBBC-070437-004	30.90
.0650	.070	.562	.004	.060	1.090	.035	.1875	2.0	QHBBC-070562-004	30.90
.0750	.080	.375	.004	.070	.590	.040	.1875	1.5	QHBBC-080375-004	30.90
.0750	.080	.500	.004	.070	.590	.040	.1875	1.5	QHBBC-080500-004	30.90
.0750	.080	.625	.004	.070	1.090	.040	.1875	2.0	QHBBC-080625-004	30.90
.0850	.090	.375	.004	.080	.590	.045	.1875	1.5	QHBBC-090375-004	30.90
.0850	.090	.500	.004	.080	.590	.045	.1875	1.5	QHBBC-090500-004	30.90
.0850	.090	.687	.004	.080	1.090	.045	.1875	2.0	QHBBC-090687-004	30.90
.0950	.100	.437	.004	.090	.590	.050	.1875	1.5	QHBBC-100437-004	30.90
.0950	.100	.562	.004	.090	1.090	.050	.1875	2.0	QHBBC-100562-004	30.90
.0950	.100	.750	.004	.090	1.090	.050	.1875	2.0	QHBBC-100750-004	30.90
.1100	.120	.500	.004	.100	.590	.060	.1875	1.5	QHBBC-120500-004	30.90
.1100	.120	.625	.004	.100	1.090	.060	.1875	2.0	QHBBC-120625-004	30.90
.1100	.120	1.000	.004	.100	1.090	.060	.1875	2.0	QHBBC-1201000-004	30.90

Continued on next page

See pg 50-62 for quick change holder options

# Quick Change – Boring Tools

## Helical Back Rake – Corner Radius (cont.)

QHBBC

Continued from previous page

Minimum Bore Diameter	Rotational Minimum Bore Diameter	Maximum Bore Depth	Radius	Neck Diameter	Length From Holder	Centerline Offset	Shank Diameter	Overall Length	Uncoated	
D1	D <sub>r</sub>	L <sub>2</sub> <sup>+ .050"</sup> <sub>– .000"</sub>	R <sup>+ .003"</sup> <sub>– .000"</sub>	D <sub>3</sub> <sup>+ .000"</sup> <sub>– .002"</sub>	L <sub>4</sub>	F	D <sub>2</sub> (h6)	L <sub>1</sub>	Tool #	Price
.1225	.135	.562	.004	.110	1.090	.068	.1875	2.0	QHBBC-135562-004	30.90
.1225	.135	.750	.004	.110	1.090	.068	.1875	2.0	QHBBC-135750-004	30.90
.1225	.135	1.000	.004	.110	1.090	.068	.1875	2.0	QHBBC-1351000-004	30.90
.1400	.150	.625	.004	.130	1.090	.075	.1875	2.0	QHBBC-1500625-004	30.90
.1400	.150	1.000	.004	.130	1.090	.075	.1875	2.0	QHBBC-1501000-004	30.90
.1400	.150	1.250	.004	.130	1.590	.075	.1875	2.5	QHBBC-1501250-004	30.90
.1700	.180	1.000	.004	.160	1.090	.090	.1875	2.0	QHBBC-1801000-004	30.90
.1700	.180	1.250	.004	.160	1.590	.090	.1875	2.5	QHBBC-1801250-004	30.90
.1700	.180	1.500	.004	.160	1.590	.090	.1875	2.5	QHBBC-1801500-004	30.90
.1975	.210	1.000	.004	.185	1.353	.105	.2500	2.5	QHBBC-2101000-004	35.05
.1975	.210	1.250	.004	.185	1.353	.105	.2500	2.5	QHBBC-2101250-004	35.05
.1975	.210	1.500	.004	.185	1.853	.105	.2500	3.0	QHBBC-2101500-004	35.05
.2275	.240	1.000	.004	.215	1.353	.120	.2500	2.5	QHBBC-2401000-004	35.05
.2275	.240	1.500	.004	.215	1.853	.120	.2500	3.0	QHBBC-2401500-004	35.05
.2275	.240	1.750	.004	.215	1.853	.120	.2500	3.0	QHBBC-2401750-004	35.05
.2750	.300	1.000	.004	.250	1.353	.150	.3125	2.5	QHBBC-3001000-004	46.15
.2750	.300	1.500	.004	.250	1.853	.150	.3125	3.0	QHBBC-3001500-004	46.15
.2750	.300	1.750	.004	.250	1.853	.150	.3125	3.0	QHBBC-3001750-004	46.15
.3400	.360	1.000	.004	.320	1.353	.180	.3750	2.5	QHBBC-3601000-004	62.85
.3400	.360	1.500	.004	.320	1.853	.180	.3750	3.0	QHBBC-3601500-004	62.85
.3400	.360	2.000	.004	.320	2.353	.180	.3750	3.5	QHBBC-3602000-004	78.45
.3400	.360	2.500	.004	.320	2.853	.180	.3750	4.0	QHBBC-3602500-004	78.45

See pg 50-62 for quick change holder options

Quick Change – Boring Tools

**QBT**

**Quick Change – Boring Tools**  
Top Rake Chipbreaker

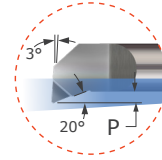
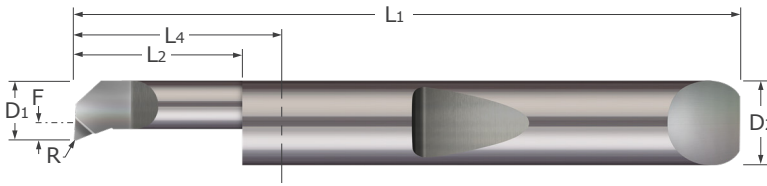

- Optimized for finishing operations
- Top rake geometry provides freer cutting
- Polished face for reducing galling
- Coolant fed enabled shank design
- Corner radius profile
- Proprietary Micro-Quik™ quick change system maximizes productivity through reliable accuracy and locational repeatability
- AlTiN coated option provides added lubricity and increased wear resistance in difficult to machine materials
- Solid carbide ■ CNC ground in the USA

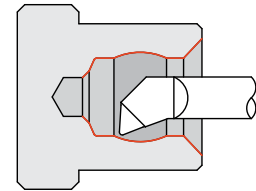

Minimum Bore Diameter	Maximum Bore Depth	Radius	Projection	Length From Holder	Centerline Offset	Shank Dia.	Overall Length	Uncoated		AlTiN Coated	
D1	L2 <sup>+ .030"</sup> <sub>- .000"</sub>	R <sup>+ .0005"</sup> <sub>- .0005"</sub>	P	L4	F	D2 (h6)	L1	Tool #	Price	Tool #	Price
.0500	.200	.002	.005	.590	-.044	.1875	1.5	QBT-050200	31.05	QBT-050200X	32.95
.0500	.400	.002	.005	.590	-.044	.1875	1.5	QBT-050400	31.05	QBT-050400X	32.95
.0500	.500	.002	.005	.590	-.044	.1875	1.5	QBT-050500	31.05	QBT-050500X	32.95
.0600	.200	.002	.010	.590	-.034	.1875	1.5	QBT-060200	31.05	QBT-060200X	32.95
.0600	.400	.002	.010	.590	-.034	.1875	1.5	QBT-060400	31.05	QBT-060400X	32.95
.0600	.500	.002	.010	.590	-.034	.1875	1.5	QBT-060500	31.05	QBT-060500X	32.95
.0700	.200	.004	.015	.590	-.024	.1875	1.5	QBT-070200	31.05	QBT-070200X	32.95
.0700	.400	.004	.015	.590	-.024	.1875	1.5	QBT-070400	31.05	QBT-070400X	32.95
.0700	.600	.004	.015	1.090	-.024	.1875	2.0	QBT-070600	31.05	QBT-070600X	32.95
.1100	.250	.004	.015	.590	.016	.1875	1.5	QBT-110250	31.05	QBT-110250X	32.95
.1100	.500	.004	.015	.590	.016	.1875	1.5	QBT-110500	31.05	QBT-110500X	32.95
.1100	.750	.004	.015	1.090	.016	.1875	2.0	QBT-110750	31.05	QBT-110750X	32.95
.1200	.250	.004	.020	.590	.026	.1875	1.5	QBT-120250	31.05	QBT-120250X	32.95
.1200	.500	.004	.020	.590	.026	.1875	1.5	QBT-120500	31.05	QBT-120500X	32.95
.1200	.750	.004	.020	1.090	.026	.1875	2.0	QBT-120750	31.05	QBT-120750X	32.95
.1200	1.000	.004	.020	1.090	.026	.1875	2.0	QBT-1201000	31.05	QBT-1201000X	32.95
.1600	.500	.006	.025	.590	.066	.1875	1.5	QBT-160500	31.05	QBT-160500X	32.95
.1600	.750	.006	.025	1.090	.066	.1875	2.0	QBT-160750	31.05	QBT-160750X	32.95
.1600	1.000	.006	.025	1.090	.066	.1875	2.0	QBT-1601000	31.05	QBT-1601000X	32.95
.1600	1.250	.006	.025	1.590	.066	.1875	2.5	QBT-1601250	31.05	QBT-1601250X	34.00
.1800	.500	.006	.030	.853	.055	.2500	2.0	QBT-180500	38.85	QBT-180500X	42.75
.1800	.750	.006	.030	.853	.055	.2500	2.0	QBT-180750	38.85	QBT-180750X	42.75
.1800	1.000	.006	.030	1.353	.055	.2500	2.5	QBT-1801000	38.85	QBT-1801000X	42.75
.1800	1.250	.006	.030	1.353	.055	.2500	2.5	QBT-1801250	38.85	QBT-1801250X	42.75
.1800	1.500	.006	.030	1.853	.055	.2500	3.0	QBT-1801500	44.65	QBT-1801500X	48.55
.2000	.600	.006	.030	.853	.075	.2500	2.0	QBT-200600	38.85	QBT-200600X	42.75
.2000	1.000	.006	.030	1.353	.075	.2500	2.5	QBT-2001000	38.85	QBT-2001000X	42.75
.2000	1.250	.006	.030	1.353	.075	.2500	2.5	QBT-2001250	38.85	QBT-2001250X	42.75
.2000	1.500	.006	.030	1.853	.075	.2500	3.0	QBT-2001500	44.65	QBT-2001500X	48.55

Continued on next page

See pg 50-62 for quick change holder options

# Quick Change – Boring Tools

**QBT**

## Top Rake Chipbreaker (cont.)

Continued from previous page

Minimum Bore Diameter	Maximum Bore Depth	Radius	Projection	Length From Holder	Centerline Offset	Shank Dia.	Overall Length	Uncoated		AlTiN Coated	
D1	L2 <sup>+0.030"</sup> <sub>-.000"</sub>	R <sup>+0.0005"</sup> <sub>-.0005"</sub>	P	L4	F	D2 (h6)	L1	Tool #	Price	Tool #	Price
.2300	.750	.006	.040	.853	.074	.3125	2.0	QBT-230750	48.45	QBT-230750X	52.65
.2300	1.100	.006	.040	1.353	.074	.3125	2.5	QBT-2301100	48.45	QBT-2301100X	54.25
.2300	1.300	.006	.040	1.353	.074	.3125	2.5	QBT-2301300	48.45	QBT-2301300X	54.25
.2300	1.600	.006	.040	1.853	.074	.3125	3.0	QBT-2301600	56.50	QBT-2301600X	62.30
.3000	1.000	.006	.050	1.353	.113	.3750	2.5	QBT-3001000	58.25	QBT-3001000X	64.05
.3000	1.600	.006	.050	1.853	.113	.3750	3.0	QBT-3001600	65.15	QBT-3001600X	70.95
.3000	2.100	.006	.050	2.853	.113	.3750	3.5	QBT-3002100	70.95	QBT-3002100X	78.40
.3600	1.000	.006	.050	1.353	.173	.3750	2.5	QBT-3601000	58.25	QBT-3601000X	64.05
.3600	1.600	.006	.050	1.853	.173	.3750	3.0	QBT-3601600	65.15	QBT-3601600X	70.95
.3600	2.100	.006	.050	2.353	.173	.3750	3.5	QBT-3602100	70.95	QBT-3602100X	78.40
.4600	1.000	.006	.075	1.040	.210	.5000	2.5	QBT-4601000	88.50	QBT-4601000X	95.65
.4600	1.600	.006	.075	2.040	.210	.5000	3.5	QBT-4601600	88.50	QBT-4601600X	95.65
.4600	2.100	.006	.075	2.540	.210	.5000	4.0	QBT-4602100	93.45	QBT-4602100X	102.75
.4900	1.000	.006	.075	1.040	.240	.5000	2.5	QBT-4901000	88.50	QBT-4901000X	95.65
.4900	1.600	.006	.075	2.040	.240	.5000	3.5	QBT-4901600	88.50	QBT-4901600X	95.65
.4900	2.100	.006	.075	2.540	.240	.5000	4.0	QBT-4902100	93.45	QBT-4902100X	102.75

See pg 50-62 for quick change holder options

Quick Change – Boring Tools

QBM

Quick Change – Boring Tools  
Boring Head Tools

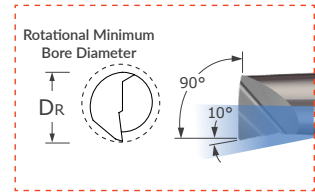
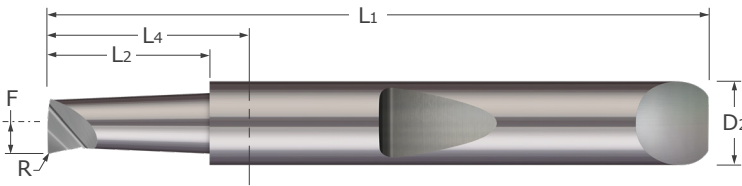

- Designed for boring applications requiring maximum rigidity
- Tapered neck and top rake geometry for increased performance
- Polished face for reducing galling
- Coolant fed enabled shank design
- Corner radius profile
- Proprietary Micro-Quik™ quick change system maximizes productivity through reliable accuracy and locational repeatability
- AlTiN coated option provides added lubricity and increased wear resistance in difficult to machine materials
- Solid carbide ■ CNC ground in the USA

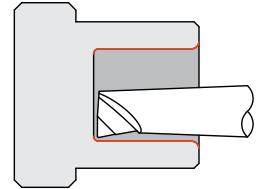

Quick Change – Boring Tools

Rotational Minimum Bore Diameter	Maximum Bore Depth	Radius	Length From Holder	Centerline Offset	Shank Diameter	Overall Length	Uncoated		AlTiN Coated	
							Tool #	Price	Tool #	Price
D <sub>R</sub>	L <sub>2</sub> <sup>+0.030"</sup> / <sub>-.000"</sub>	R <sup>+0.001"</sup> / <sub>-.001"</sub>	L <sub>4</sub>	F <sup>+0.0005"</sup> / <sub>-.0005"</sub>	D <sub>2</sub> (h6)	L <sub>1</sub>				
.1180	.500	.003	.853	.0550	.2500	2.0	QBM-118500	33.30	QBM-118500X	37.20
.1180	.750	.003	.853	.0550	.2500	2.0	QBM-118750	33.30	QBM-118750X	37.20
.1500	.500	.003	.853	.0710	.2500	2.0	QBM-150500	33.30	QBM-150500X	37.20
.1500	.750	.003	.853	.0710	.2500	2.0	QBM-150750	33.30	QBM-150750X	37.20
.2000	.500	.008	.853	.0950	.2500	2.0	QBM-200500	33.30	QBM-200500X	37.20
.2000	.750	.008	.853	.0950	.2500	2.0	QBM-200750	33.30	QBM-200750X	37.20
.2000	1.250	.008	1.353	.0950	.2500	2.5	QBM-2001250	33.30	QBM-2001250X	37.20
.2300	.750	.008	.853	.1100	.2500	2.0	QBM-230750	33.30	QBM-230750X	37.20
.2300	1.250	.008	1.353	.1100	.2500	2.5	QBM-2301250	33.30	QBM-2301250X	37.20
.2300	1.500	.008	1.853	.1100	.2500	3.0	QBM-2301500	37.70	QBM-2301500X	41.60
.3000	1.000	.008	1.353	.1450	.3750	2.5	QBM-3001000	60.95	QBM-3001000X	66.75
.3000	1.500	.008	1.853	.1450	.3750	3.0	QBM-3001500	67.75	QBM-3001500X	73.55
.3000	1.750	.008	1.853	.1450	.3750	3.0	QBM-3001750	67.75	QBM-3001750X	73.55
.3600	1.000	.008	1.353	.1750	.3750	2.5	QBM-3601000	60.95	QBM-3601000X	66.75
.3600	1.500	.008	1.853	.1750	.3750	3.0	QBM-3601500	67.75	QBM-3601500X	73.55
.3600	2.000	.008	2.353	.1750	.3750	3.5	QBM-3602000	73.80	QBM-3602000X	79.60
.4600	1.000	.008	1.040	.2250	.5000	2.5	QBM-4601000	84.90	QBM-4601000X	92.05
.4600	1.500	.008	1.540	.2250	.5000	3.0	QBM-4601500	84.90	QBM-4601500X	92.05
.4600	2.000	.008	2.040	.2250	.5000	3.5	QBM-4602000	93.15	QBM-4602000X	102.45
.4600	2.500	.008	2.540	.2250	.5000	4.0	QBM-4602500	98.60	QBM-4602500X	107.90
.4600	3.000	.008	3.040	.2250	.5000	4.5	QBM-4603000	103.30	QBM-4603000X	114.35

See pg 50-62 for quick change holder options

# Quick Change – Boring Tools

QRB

## Reverse Boring

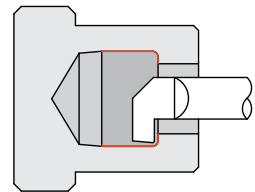
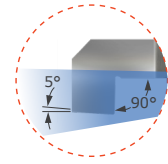
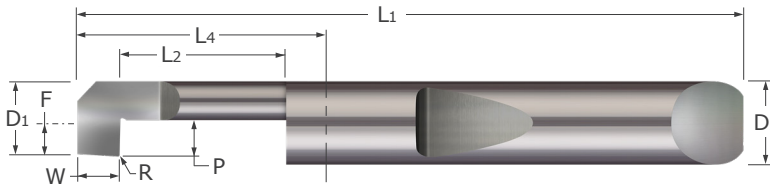

Quick Change – Boring Tools

- Designed to bore from the inside, toward the face of the part
- Polished split face for improved edge retention and chip evacuation while reducing galling
- Split geometry makes the tool as rigid as possible
- Coolant fed enabled shank design
- Inside corner radius profile
- Proprietary Micro-Quik™ quick change system maximizes productivity through reliable accuracy and locational repeatability
- AlTiN coated option provides added lubricity and increased wear resistance in difficult to machine materials
- Solid carbide ■ CNC ground in the USA

Minimum Bore Dia.	Maximum Bore Depth	Width	Radius	Projection	Length From Holder	Centerline Offset	Shank Dia.	Overall Length	Uncoated		AlTiN Coated	
D1	L2 <sup>+0.015"</sup> <sub>-.000"</sub>	W <sup>+0.002"</sup> <sub>-.000"</sub>	R <sup>+0.001"</sup> <sub>-.001"</sub>	P	L4	F	D2 (h6)	L1	Tool #	Price	Tool #	Price
.1560	.500	.075	.005	.060	.590	.062	.1875	1.5	QRB-156500	30.85	QRB-156500X	32.75
.1560	.750	.075	.005	.060	1.090	.062	.1875	2.0	QRB-156750	30.85	QRB-156750X	32.75
.1560	1.000	.075	.005	.060	1.090	.062	.1875	2.0	QRB-1561000	30.85	QRB-1561000X	32.75
.1800	.500	.100	.005	.080	.853	.055	.2500	2.0	QRB-180500	33.30	QRB-180500X	37.20
.1800	.750	.100	.005	.080	1.353	.055	.2500	2.5	QRB-180750	33.30	QRB-180750X	37.20
.1800	1.000	.100	.005	.080	1.353	.055	.2500	2.5	QRB-1801000	33.30	QRB-1801000X	37.20
.2000	.500	.113	.008	.090	.853	.075	.2500	2.0	QRB-200500	33.30	QRB-200500X	37.20
.2000	.750	.113	.008	.090	1.353	.075	.2500	2.5	QRB-200750	33.30	QRB-200750X	37.20
.2000	1.000	.113	.008	.090	1.353	.075	.2500	2.5	QRB-2001000	33.30	QRB-2001000X	37.20
.2000	1.250	.113	.008	.090	1.853	.075	.2500	3.0	QRB-2001250	39.10	QRB-2001250X	43.00
.2300	.500	.138	.008	.110	.853	.073	.3125	2.0	QRB-230500	44.70	QRB-230500X	48.90
.2300	.750	.138	.008	.110	1.353	.073	.3125	2.5	QRB-230750	44.70	QRB-230750X	50.50
.2300	1.000	.138	.008	.110	1.353	.073	.3125	2.5	QRB-2301000	44.70	QRB-2301000X	50.50
.2300	1.250	.138	.008	.110	1.853	.073	.3125	3.0	QRB-2301250	51.40	QRB-2301250X	57.20
.3000	.500	.138	.008	.110	.853	.143	.3125	2.0	QRB-300500	44.70	QRB-300500X	48.90
.3000	.750	.138	.008	.110	1.353	.143	.3125	2.5	QRB-300750	44.70	QRB-300750X	48.90
.3000	1.000	.138	.008	.110	1.353	.143	.3125	2.5	QRB-3001000	44.70	QRB-3001000X	50.50
.3000	1.250	.138	.008	.110	1.853	.143	.3125	3.0	QRB-3001250	51.40	QRB-3001250X	57.20
.3600	.750	.163	.008	.130	1.353	.172	.3750	2.5	QRB-360750	60.95	QRB-360750X	66.75
.3600	1.000	.163	.008	.130	1.353	.172	.3750	2.5	QRB-3601000	60.95	QRB-3601000X	66.75
.3600	1.250	.163	.008	.130	1.853	.172	.3750	3.0	QRB-3601250	67.75	QRB-3601250X	73.55
.3600	1.500	.163	.008	.130	1.853	.172	.3750	3.0	QRB-3601500	67.75	QRB-3601500X	75.20
.4600	1.000	.200	.008	.160	1.540	.210	.5000	3.0	QRB-4601000	84.90	QRB-4601000X	92.05
.4600	1.250	.200	.008	.160	1.540	.210	.5000	3.0	QRB-4601250	84.90	QRB-4601250X	94.20
.4600	1.500	.200	.008	.160	2.040	.210	.5000	3.5	QRB-4601500	93.15	QRB-4601500X	102.45
.4600	1.800	.200	.008	.160	2.040	.210	.5000	3.5	QRB-4601800	93.15	QRB-4601800X	104.20
.4900	1.000	.200	.008	.160	1.540	.240	.5000	3.0	QRB-4901000	84.90	QRB-4901000X	92.05
.4900	1.250	.200	.008	.160	1.540	.240	.5000	3.0	QRB-4901250	84.90	QRB-4901250X	94.20
.4900	1.500	.200	.008	.160	2.040	.240	.5000	3.5	QRB-4901500	93.15	QRB-4901500X	102.45
.4900	1.800	.200	.008	.160	2.040	.240	.5000	3.5	QRB-4901800	93.15	QRB-4901800X	104.20

See pg 50-62 for quick change holder options

QPR

Quick Change – Profiling Tools

Radial Profiling

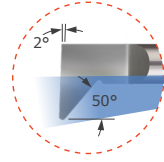
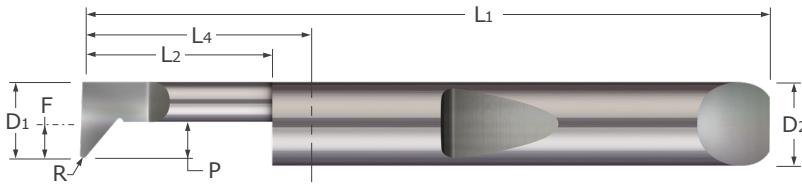

- Designed for radial profiling
- Excellent choice for fine finishing
- Can be used in thread relief applications
- Split geometry makes the tool as rigid as possible
- Coolant fed enabled shank design
- Corner radius profile
- Proprietary Micro-Quik™ quick change system maximizes productivity through reliable accuracy and locational repeatability
- AlTiN coated option provides added lubricity and increased wear resistance in difficult to machine materials
- Solid carbide ■ CNC ground in the USA

Coolant Groove Styles

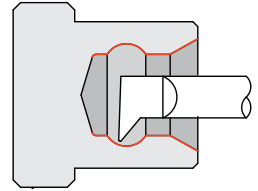

Quick Change – Profiling Tools

Minimum Bore Diameter	Maximum Bore Depth	Radius	Projection	Length From Holder	Centerline Offset	Shank Dia.	Overall Length	Uncoated		AlTiN Coated	
D1	L2 <sup>+ .030"</sup> <sub>- .000"</sub>	R <sup>+ .0005"</sup> <sub>- .0005"</sub>	P	L4	F	D2 (h6)	L1	Tool #	Price	Tool #	Price
.0700	.200	.0050	.025	.590	-.023	.1875	1.5	QPR-070200	31.05	QPR-070200X	32.95
.0700	.300	.0050	.025	.590	-.023	.1875	1.5	QPR-070300	31.05	QPR-070300X	32.95
.0700	.500	.0050	.025	.590	-.023	.1875	1.5	QPR-070500	31.05	QPR-070500X	32.95
.1100	.250	.0050	.040	.590	.016	.1875	1.5	QPR-110250	31.05	QPR-110250X	32.95
.1100	.500	.0050	.040	.590	.016	.1875	1.5	QPR-110500	31.05	QPR-110500X	32.95
.1200	.250	.0080	.050	.590	.026	.1875	1.5	QPR-120250	31.05	QPR-120250X	32.95
.1200	.500	.0080	.050	.590	.026	.1875	1.5	QPR-120500	31.05	QPR-120500X	32.95
.1200	.750	.0080	.050	1.090	.026	.1875	2.0	QPR-120750	31.05	QPR-120750X	32.95
.1600	.500	.0080	.050	.590	.066	.1875	1.5	QPR-160500	31.05	QPR-160500X	32.95
.1600	.750	.0080	.050	1.090	.066	.1875	2.0	QPR-160750	31.05	QPR-160750X	32.95
.1600	1.000	.0080	.050	1.090	.066	.1875	2.0	QPR-1601000	31.05	QPR-1601000X	32.95
.1800	.500	.0080	.080	.853	.055	.2500	2.0	QPR-180500	38.85	QPR-180500X	42.75
.1800	.750	.0080	.080	.853	.055	.2500	2.0	QPR-180750	38.85	QPR-180750X	42.75
.1800	1.000	.0080	.080	1.353	.055	.2500	2.5	QPR-1801000	38.85	QPR-1801000X	42.75
.2300	.750	.0080	.080	.853	.073	.3125	2.0	QPR-230750	48.45	QPR-230750X	52.65
.2300	1.000	.0080	.080	1.353	.073	.3125	2.5	QPR-2301000	48.45	QPR-2301000X	54.25
.2300	1.250	.0080	.080	1.353	.073	.3125	2.5	QPR-2301250	48.45	QPR-2301250X	54.25
.3000	1.000	.0080	.110	1.353	.143	.3125	2.5	QPR-3001000	48.45	QPR-3001000X	54.25
.3000	1.250	.0080	.110	1.353	.143	.3125	2.5	QPR-3001250	48.45	QPR-3001250X	54.25
.3600	1.000	.0080	.130	1.353	.172	.3750	2.5	QPR-3601000	63.15	QPR-3601000X	68.95
.3600	1.250	.0080	.130	1.353	.172	.3750	2.5	QPR-3601250	63.15	QPR-3601250X	68.95
.4600	1.000	.0080	.150	1.540	.210	.5000	3.0	QPR-4601000	88.50	QPR-4601000X	95.65
.4600	1.500	.0080	.150	1.540	.210	.5000	3.0	QPR-4601500	88.50	QPR-4601500X	95.65
.4600	1.800	.0080	.150	2.040	.210	.5000	3.5	QPR-4601800	96.65	QPR-4601800X	105.95
.4900	1.000	.0080	.150	1.540	.240	.5000	3.0	QPR-4901000	88.50	QPR-4901000X	95.65
.4900	1.500	.0080	.150	1.540	.240	.5000	3.0	QPR-4901500	88.50	QPR-4901500X	95.65
.4900	1.800	.0080	.150	2.040	.240	.5000	3.5	QPR-4901800	96.65	QPR-4901800X	105.95

See pg 50-62 for quick change holder options

# Quick Change – Profiling Tools

QPF

## Axial Profiling

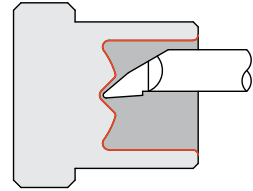
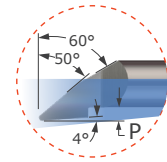
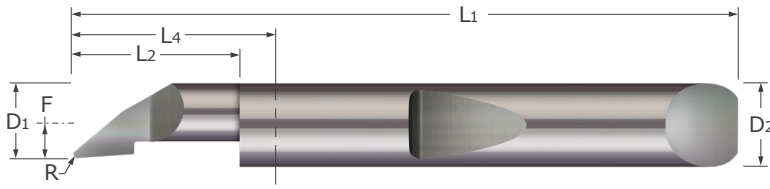

Quick Change – Profiling Tools

- Designed for both radial and axial profiling
- Unique design maximizes tool versatility and part feature creation
- Polished split face for improved edge retention and chip evacuation while reducing galling
- Split geometry makes the tool as rigid as possible
- Coolant fed enabled shank design
- Corner radius profile
- Proprietary Micro-Quik™ quick change system maximizes productivity through reliable accuracy and locational repeatability
- AlTiN coated option provides added lubricity and increased wear resistance in difficult to machine materials
- Solid carbide ■ CNC ground in the USA

Minimum Bore Diameter	Maximum Bore Depth	Radius	Projection	Length From Holder	Centerline Offset	Shank Dia.	Overall Length	Uncoated		AlTiN Coated	
D1	L2	R	P	L4	F	D2 (h6)	L1	Tool #	Price	Tool #	Price
.0500	.200	.0050	.005	.590	-.044	.1875	1.5	QPF-050200	31.05	QPF-050200X	32.95
.0500	.400	.0050	.005	.590	-.044	.1875	1.5	QPF-050400	31.05	QPF-050400X	32.95
.0500	.500	.0050	.005	.590	-.044	.1875	1.5	QPF-050500	31.05	QPF-050500X	32.95
.0600	.200	.0050	.005	.590	-.034	.1875	1.5	QPF-060200	31.05	QPF-060200X	32.95
.0600	.400	.0050	.005	.590	-.034	.1875	1.5	QPF-060400	31.05	QPF-060400X	32.95
.0600	.500	.0050	.005	.590	-.034	.1875	1.5	QPF-060500	31.05	QPF-060500X	32.95
.0700	.200	.0050	.010	.590	-.024	.1875	1.5	QPF-070200	31.05	QPF-070200X	32.95
.0700	.400	.0050	.010	.590	-.024	.1875	1.5	QPF-070400	31.05	QPF-070400X	32.95
.0700	.500	.0050	.010	.590	-.024	.1875	1.5	QPF-070500	31.05	QPF-070500X	32.95
.0700	.600	.0050	.010	1.090	-.024	.1875	2.0	QPF-070600	31.05	QPF-070600X	32.95
.1100	.250	.0050	.015	.590	.016	.1875	1.5	QPF-110250	31.05	QPF-110250X	32.95
.1100	.500	.0050	.015	.590	.016	.1875	1.5	QPF-110500	31.05	QPF-110500X	32.95
.1100	.750	.0050	.015	1.090	.016	.1875	2.0	QPF-110750	31.05	QPF-110750X	32.95
.1200	.250	.0080	.020	.590	.026	.1875	1.5	QPF-120250	31.05	QPF-120250X	32.95
.1200	.500	.0080	.020	.590	.026	.1875	1.5	QPF-120500	31.05	QPF-120500X	32.95
.1200	.750	.0080	.020	1.090	.026	.1875	2.0	QPF-120750	31.05	QPF-120750X	32.95
.1200	1.000	.0080	.020	1.090	.026	.1875	2.0	QPF-1201000	31.05	QPF-1201000X	32.95
.1600	.500	.0080	.030	.590	.066	.1875	1.5	QPF-160500	31.05	QPF-160500X	32.95
.1600	.750	.0080	.030	1.090	.066	.1875	2.0	QPF-160750	31.05	QPF-160750X	32.95
.1600	1.000	.0080	.030	1.090	.066	.1875	2.0	QPF-1601000	31.05	QPF-1601000X	32.95
.1800	.500	.0080	.030	.853	.055	.2500	2.0	QPF-180500	38.85	QPF-180500X	42.75
.1800	.750	.0080	.030	.853	.055	.2500	2.0	QPF-180750	38.85	QPF-180750X	42.75
.1800	1.000	.0080	.030	1.353	.055	.2500	2.5	QPF-1801000	38.85	QPF-1801000X	42.75
.2000	.600	.0080	.030	.853	.075	.2500	2.0	QPF-200600	38.85	QPF-200600X	42.75
.2000	1.000	.0080	.030	1.353	.075	.2500	2.5	QPF-2001000	38.85	QPF-2001000X	42.75
.2300	.750	.0080	.030	.853	.074	.3125	2.0	QPF-230750	48.45	QPF-230750X	52.65
.2300	1.000	.0080	.030	1.353	.074	.3125	2.5	QPF-2301000	48.45	QPF-2301000X	54.25
.2300	1.100	.0080	.030	1.353	.074	.3125	2.5	QPF-2301100	48.45	QPF-2301100X	54.25
.2300	1.250	.0080	.030	1.353	.074	.3125	2.5	QPF-2301250	48.45	QPF-2301250X	54.25

Continued on next page

See pg 50-62 for quick change holder options



## QPF

## Quick Change – Profiling Tools

## Axial Profiling (cont.)

Continued from previous page

Minimum Bore Diameter	Maximum Bore Depth	Radius	Projection	Length From Holder	Centerline Offset	Shank Dia.	Overall Length	Uncoated		AlTiN Coated	
D1	L2 $\begin{matrix} +.030'' \\ -.000'' \end{matrix}$	R $\begin{matrix} +.0005'' \\ -.0005'' \end{matrix}$	P	L4	F	D2 (h6)	L1	Tool #	Price	Tool #	Price
.3000	1.000	.0080	.030	1.353	.144	.3125	2.5	QPF-3001000	48.45	QPF-3001000X	54.25
.3000	1.250	.0080	.030	1.353	.144	.3125	2.5	QPF-3001250	48.45	QPF-3001250X	54.25
.3600	1.000	.0080	.030	1.353	.173	.3750	2.5	QPF-3601000	63.15	QPF-3601000X	68.95
.3600	1.250	.0080	.030	1.353	.173	.3750	2.5	QPF-3601250	63.15	QPF-3601250X	68.95
.4600	1.000	.0080	.050	1.040	.210	.5000	2.5	QPF-4601000	88.50	QPF-4601000X	95.65
.4600	1.600	.0080	.050	2.040	.210	.5000	3.5			QPF-4601600X	105.95
.4900	1.600	.0080	.050	2.040	.240	.5000	3.5			QPF-4901600X	105.95
.4900	1.800	.0080	.050	2.040	.240	.5000	3.5			QPF-4901800X	105.95

See pg 50-62 for quick change holder options

# Quick Change – Grooving Tools

## Retaining Ring – Square – Miniature

QMRR

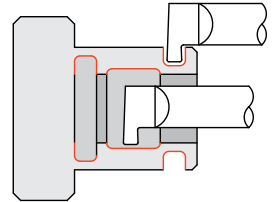
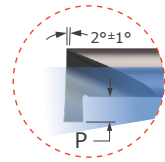
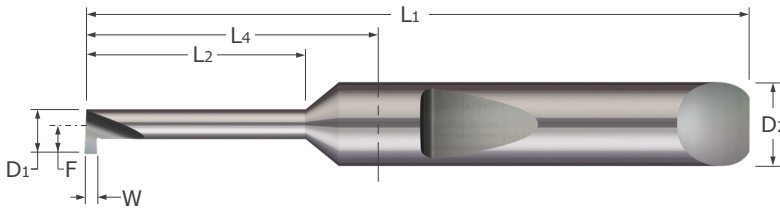

- Designed for generating retaining ring grooves in bores .060" and larger
- Polished face for improved edge retention and chip evacuation while reducing galling
- On-center neck design
- Coolant fed enabled shank design
- Sharp corner profile
- Proprietary Micro-Quik™ quick change system maximizes productivity through reliable accuracy and locational repeatability
- AlTiN coated option provides added lubricity and increased wear resistance in difficult to machine materials
- Solid carbide ■ CNC ground in the USA

Quick Change – Grooving Tools

Width	Minimum Bore Dia.	Maximum Bore Depth	Projection	Length From Holder	Centerline Offset	Shank Dia.	Overall Length	Uncoated		AlTiN Coated	
W $\begin{smallmatrix} +.002" \\ -.000" \end{smallmatrix}$	D1	L2 $\begin{smallmatrix} +.030" \\ -.000" \end{smallmatrix}$	P	L4	F	D2 (h6)	L1	Tool #	Price	Tool #	Price
.010	.0600	.100	.020	.590	.040	.1875	1.5	QMRR-010-100-060	43.20	QMRR-010-100-060X	45.10
.010	.0600	.150	.020	.590	.040	.1875	1.5	QMRR-010-150-060	43.20	QMRR-010-150-060X	45.10
.010	.0600	.250	.020	.590	.040	.1875	1.5	QMRR-010-250-060	43.20	QMRR-010-250-060X	45.10
.015	.0600	.100	.020	.590	.040	.1875	1.5	QMRR-015-100-060	43.20	QMRR-015-100-060X	45.10
.015	.0600	.150	.020	.590	.040	.1875	1.5	QMRR-015-150-060	43.20	QMRR-015-150-060X	45.10
.015	.0600	.250	.020	.590	.040	.1875	1.5	QMRR-015-250-060	43.20	QMRR-015-250-060X	45.10
.015	.0800	.250	.025	.590	.053	.1875	1.5	QMRR-015-250-080	43.20	QMRR-015-250-080X	45.10
.015	.0800	.375	.025	.590	.053	.1875	1.5	QMRR-015-375-080	43.20	QMRR-015-375-080X	45.10
.015	.0800	.500	.025	.590	.053	.1875	1.5	QMRR-015-500-080	43.20	QMRR-015-500-080X	45.10
.015	.1000	.250	.030	.590	.065	.1875	1.5	QMRR-015-250-100	43.20	QMRR-015-250-100X	45.10
.015	.1000	.500	.030	.590	.065	.1875	1.5	QMRR-015-500-100	43.20	QMRR-015-500-100X	45.10
.015	.1000	.750	.030	1.090	.065	.1875	2.0	QMRR-015-750-100	43.20	QMRR-015-750-100X	45.10
.017	.1200	.150	.040	.590	.080	.1875	1.5	QMRR-017-150-120	43.20	QMRR-017-150-120X	45.10 NEW
.017	.1200	.250	.040	.590	.080	.1875	1.5	QMRR-017-250-120	43.20	QMRR-017-250-120X	45.10 NEW
.020	.0600	.100	.020	.590	.040	.1875	1.5	QMRR-020-100-060	38.85	QMRR-020-100-060X	40.75
.020	.0600	.150	.020	.590	.040	.1875	1.5	QMRR-020-150-060	38.85	QMRR-020-150-060X	40.75
.020	.0600	.250	.020	.590	.040	.1875	1.5	QMRR-020-250-060	38.85	QMRR-020-250-060X	40.75
.020	.0700	.100	.020	.590	.045	.1875	1.5	QMRR-020-100-070	38.85	QMRR-020-100-070X	40.75 NEW
.020	.0700	.150	.020	.590	.045	.1875	1.5	QMRR-020-150-070	38.85	QMRR-020-150-070X	40.75 NEW
.020	.0800	.150	.025	.590	.053	.1875	1.5	QMRR-020-150-080	38.85	QMRR-020-150-080X	40.75 NEW
.020	.0800	.250	.025	.590	.053	.1875	1.5	QMRR-020-250-080	38.85	QMRR-020-250-080X	40.75
.020	.0800	.375	.025	.590	.053	.1875	1.5	QMRR-020-375-080	38.85	QMRR-020-375-080X	40.75
.020	.0800	.500	.025	.590	.053	.1875	1.5	QMRR-020-500-080	38.85	QMRR-020-500-080X	40.75
.020	.0900	.150	.025	.590	.058	.1875	1.5	QMRR-020-150-090	38.85	QMRR-020-150-090X	40.75 NEW
.020	.0900	.250	.025	.590	.058	.1875	1.5	QMRR-020-250-090	38.85	QMRR-020-250-090X	40.75 NEW
.020	.1000	.150	.030	.590	.065	.1875	1.5	QMRR-020-150-100	38.85	QMRR-020-150-100X	40.75 NEW
.020	.1000	.250	.030	.590	.065	.1875	1.5	QMRR-020-250-100	38.85	QMRR-020-250-100X	40.75
.020	.1000	.500	.030	.590	.065	.1875	1.5	QMRR-020-500-100	38.85	QMRR-020-500-100X	40.75
.020	.1000	.750	.030	1.090	.065	.1875	2.0	QMRR-020-750-100	38.85	QMRR-020-750-100X	40.75

Continued on next page

See pg 50-62 for quick change holder options

## QMRR

Quick Change – Grooving Tools  
Retaining Ring – Square – Miniature (cont.)

Continued from previous page

	Width	Minimum Bore Dia.	Maximum Bore Depth	Projection	Length From Holder	Centerline Offset	Shank Dia.	Overall Length	Uncoated		AITIN Coated	
	W $\begin{smallmatrix} +.002" \\ -.000" \end{smallmatrix}$	D1	L2 $\begin{smallmatrix} +.030" \\ -.000" \end{smallmatrix}$	P	L4	F	D2 (h6)	L1	Tool #	Price	Tool #	Price
NEW	.020	.1200	.150	.040	.590	.080	.1875	1.5	QMRR-020-150-120	38.85	QMRR-020-150-120X	40.75
	.020	.1200	.250	.040	.590	.080	.1875	1.5	QMRR-020-250-120	38.85	QMRR-020-250-120X	40.75
NEW	.020	.1200	.375	.040	.590	.080	.1875	1.5	QMRR-020-375-120	38.85	QMRR-020-375-120X	40.75
	.020	.1200	.500	.040	.590	.080	.1875	1.5	QMRR-020-500-120	38.85	QMRR-020-500-120X	40.75
	.020	.1200	.750	.040	1.090	.080	.1875	2.0	QMRR-020-750-120	38.85	QMRR-020-750-120X	40.75
NEW	.025	.1200	.150	.040	.590	.080	.1875	1.5	QMRR-025-150-120	38.85	QMRR-025-150-120X	40.75
NEW	.025	.1200	.250	.040	.590	.080	.1875	1.5	QMRR-025-250-120	38.85	QMRR-025-250-120X	40.75
NEW	.030	.0700	.100	.020	.590	.045	.1875	1.5	QMRR-030-100-070	38.85	QMRR-030-100-070X	40.75
NEW	.030	.0700	.150	.020	.590	.045	.1875	1.5	QMRR-030-150-070	38.85	QMRR-030-150-070X	40.75
NEW	.030	.0800	.150	.025	.590	.053	.1875	1.5	QMRR-030-150-080	38.85	QMRR-030-150-080X	40.75
	.030	.0800	.250	.025	.590	.053	.1875	1.5	QMRR-030-250-080	38.85	QMRR-030-250-080X	40.75
	.030	.0800	.375	.025	.590	.053	.1875	1.5	QMRR-030-375-080	38.85	QMRR-030-375-080X	40.75
	.030	.0800	.500	.025	.590	.053	.1875	1.5	QMRR-030-500-080	38.85	QMRR-030-500-080X	40.75
NEW	.030	.0900	.150	.025	.590	.058	.1875	1.5	QMRR-030-150-090	38.85	QMRR-030-150-090X	40.75
NEW	.030	.0900	.250	.025	.590	.058	.1875	1.5	QMRR-030-250-090	38.85	QMRR-030-250-090X	40.75
NEW	.030	.1000	.150	.030	.590	.065	.1875	1.5	QMRR-030-150-100	38.85	QMRR-030-150-100X	40.75
	.030	.1000	.250	.030	.590	.065	.1875	1.5	QMRR-030-250-100	38.85	QMRR-030-250-100X	40.75
NEW	.030	.1000	.375	.030	.590	.065	.1875	1.5	QMRR-030-375-100	38.85	QMRR-030-375-100X	40.75
	.030	.1000	.500	.030	.590	.065	.1875	1.5	QMRR-030-500-100	38.85	QMRR-030-500-100X	40.75
	.030	.1000	.750	.030	1.090	.065	.1875	2.0	QMRR-030-750-100	38.85	QMRR-030-750-100X	40.75
NEW	.030	.1200	.150	.040	.590	.080	.1875	1.5	QMRR-030-150-120	38.85	QMRR-030-150-120X	40.75
	.030	.1200	.250	.040	.590	.080	.1875	1.5	QMRR-030-250-120	38.85	QMRR-030-250-120X	40.75
NEW	.030	.1200	.375	.040	.590	.080	.1875	1.5	QMRR-030-375-120	38.85	QMRR-030-375-120X	40.75
	.030	.1200	.500	.040	.590	.080	.1875	1.5	QMRR-030-500-120	38.85	QMRR-030-500-120X	40.75
	.030	.1200	.750	.040	1.090	.080	.1875	2.0	QMRR-030-750-120	38.85	QMRR-030-750-120X	40.75

See pg 50-62 for quick change holder options

# Quick Change – Grooving Tools

QRR

## Retaining Ring – Square

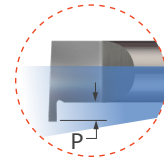
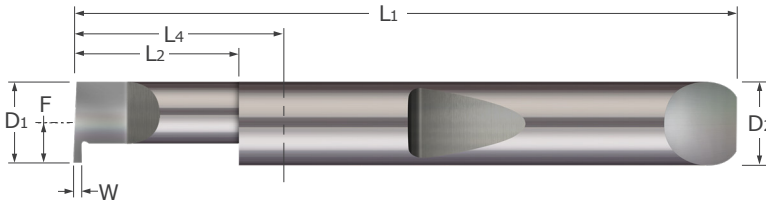

- Designed for generating retaining ring grooves in bores .180" and larger
- Polished split face for improved edge retention and chip evacuation while reducing galling
- Coolant fed enabled shank design
- Sharp corner profile
- Proprietary Micro-Quik™ quick change system maximizes productivity through reliable accuracy and locational repeatability
- AlTiN coated option provides added lubricity and increased wear resistance in difficult to machine materials
- Solid carbide ■ CNC ground in the USA

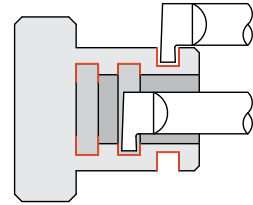

Quick Change – Grooving Tools

Width	Minimum Bore Dia.	Maximum Bore Depth	Projection	Length From Holder	Centerline Offset	Shank Dia.	Overall Length	Uncoated		AlTiN Coated	
								Tool #	Price	Tool #	Price
W <sup>+0.002"</sup> <sub>-.000"</sub>	D <sub>1</sub>	L <sub>2</sub> <sup>+0.030"</sup> <sub>-.000"</sub>	P	L <sub>4</sub>	F	D <sub>2</sub> (h6)	L <sub>1</sub>				
.017	.1800	.250	.030	.590	.086	.1875	1.5	QRR-017-4	33.05	QRR-017-4X	34.95
.017	.1800	.375	.030	.590	.086	.1875	1.5	QRR-017-6	33.05	QRR-017-6X	34.95
.017	.1800	.500	.030	.590	.086	.1875	1.5	QRR-017-8	33.05	QRR-017-8X	34.95
.017	.1800	.625	.030	1.090	.086	.1875	2.0	QRR-017-10	33.05	QRR-017-10X	34.95
.017	.1800	.750	.030	1.090	.086	.1875	2.0	QRR-017-750-180	33.05	QRR-017-750-180X	34.95 NEW
.017	.2450	.250	.050	.853	.120	.2500	2.0	QRR-017-250-245	38.85	QRR-017-250-245X	42.75 NEW
.017	.2450	.375	.050	.853	.120	.2500	2.0	QRR-017-375-245	38.85	QRR-017-375-245X	42.75 NEW
.020	.1200	.150	.030	.590	.026	.1875	1.5	QRR-020-150-120	33.05	QRR-020-150-120X	34.95 NEW
.020	.1200	.250	.030	.590	.026	.1875	1.5	QRR-020-250-120	33.05	QRR-020-250-120X	34.95 NEW
.020	.1400	.250	.030	.590	.046	.1875	1.5	QRR-020-250-140	33.05	QRR-020-250-140X	34.95 NEW
.020	.1400	.375	.030	.590	.046	.1875	1.5	QRR-020-375-140	33.05	QRR-020-375-140X	34.95 NEW
.020	.1600	.250	.030	.590	.066	.1875	1.5	QRR-020-250-160	33.05	QRR-020-250-160X	34.95 NEW
.020	.1600	.375	.030	.590	.066	.1875	1.5	QRR-020-375-160	33.05	QRR-020-375-160X	34.95 NEW
.020	.1800	.250	.030	.590	.086	.1875	1.5	QRR-020-4	33.05	QRR-020-4X	34.95
.020	.1800	.375	.030	.590	.086	.1875	1.5	QRR-020-6	33.05	QRR-020-6X	34.95
.020	.1800	.500	.030	.590	.086	.1875	1.5	QRR-020-8	33.05	QRR-020-8X	34.95
.020	.1800	.625	.030	1.090	.086	.1875	2.0	QRR-020-10	33.05	QRR-020-10X	34.95
.020	.1800	.750	.030	1.090	.086	.1875	2.0	QRR-020-750-180	38.85	QRR-020-750-180X	42.75 NEW
.020	.2450	.250	.050	.853	.120	.2500	2.0	QRR-020-250-245	38.85	QRR-020-250-245X	42.75 NEW
.020	.2450	.375	.050	.853	.120	.2500	2.0	QRR-020-375-245	38.85	QRR-020-375-245X	42.75 NEW
.020	.2450	.500	.050	.853	.120	.2500	2.0	QRR-020-500-245	38.85	QRR-020-500-245X	42.75 NEW
.020	.2450	.625	.050	.853	.120	.2500	2.0	QRR-020-625-245	38.85	QRR-020-625-245X	42.75 NEW
.025	.2450	.250	.050	.853	.120	.2500	2.0	QRR-025-4	38.85	QRR-025-4X	42.75
.025	.2450	.375	.050	.853	.120	.2500	2.0	QRR-025-6	38.85	QRR-025-6X	42.75
.025	.2450	.500	.050	.853	.120	.2500	2.0	QRR-025-8	38.85	QRR-025-8X	42.75
.025	.2450	.625	.050	.853	.120	.2500	2.0	QRR-025-10	38.85	QRR-025-10X	42.75
.025	.2450	.750	.050	.853	.120	.2500	2.0	QRR-025-750-245	38.85	QRR-025-750-245X	42.75 NEW
.030	.1200	.150	.030	.590	.026	.1875	1.5	QRR-030-150-120	33.05	QRR-030-150-120X	34.95 NEW
.030	.1200	.250	.030	.590	.026	.1875	1.5	QRR-030-250-120	33.05	QRR-030-250-120X	34.95 NEW
.030	.1400	.250	.030	.590	.046	.1875	1.5	QRR-030-250-140	33.05	QRR-030-250-140X	34.95 NEW
.030	.1400	.375	.030	.590	.046	.1875	1.5	QRR-030-375-140	33.05	QRR-030-375-140X	34.95 NEW
.030	.1600	.250	.030	.590	.066	.1875	1.5	QRR-030-250-160	33.05	QRR-030-250-160X	34.95 NEW
.030	.1600	.375	.030	.590	.066	.1875	1.5	QRR-030-375-160	33.05	QRR-030-375-160X	34.95 NEW
.030	.1800	.250	.030	.590	.086	.1875	1.5	QRR-030-250-180	33.05	QRR-030-250-180X	34.95 NEW
.030	.1800	.500	.030	.590	.086	.1875	1.5	QRR-030-500-180	33.05	QRR-030-500-180X	34.95 NEW

See pg 50-62 for quick change holder options

Continued on next page

See pg 26 for miniature sizes

## QRR

## Quick Change – Grooving Tools

## Retaining Ring – Square (cont.)

Continued from previous page

	Width	Minimum Bore Dia.	Maximum Bore Depth	Projection	Length From Holder	Centerline Offset	Shank Dia.	Overall Length	Uncoated		AlTiN Coated	
	W $\begin{smallmatrix} +.002'' \\ -.000'' \end{smallmatrix}$	D1	L2 $\begin{smallmatrix} +.030'' \\ -.000'' \end{smallmatrix}$	P	L4	F	D2 (h6)	L1	Tool #	Price	Tool #	Price
	.030	.2450	.250	.050	.853	.120	.2500	2.0	QRR-030-4	38.85	QRR-030-4X	42.75
	.030	.2450	.375	.050	.853	.120	.2500	2.0	QRR-030-6	38.85	QRR-030-6X	42.75
	.030	.2450	.500	.050	.853	.120	.2500	2.0	QRR-030-8	38.85	QRR-030-8X	42.75
	.030	.2450	.625	.050	.853	.120	.2500	2.0	QRR-030-10	38.85	QRR-030-10X	42.75
NEW	.030	.2450	.750	.050	.853	.120	.2500	2.0	QRR-030-750-245	38.85	QRR-030-750-245X	42.75
NEW	.030	.3100	.500	.100	.853	.153	.3125	2.0	QRR-030-500-310	48.45	QRR-030-500-310X	52.65
NEW	.030	.3100	.750	.100	.853	.153	.3125	2.0	QRR-030-750-310	48.45	QRR-030-750-310X	52.65
NEW	.033	.3100	.250	.100	.853	.153	.3125	2.0	QRR-033-250-310	48.45	QRR-033-250-310X	52.65
	.033	.3100	.375	.100	.853	.154	.3125	2.0	QRR-033-6	48.45	QRR-033-6X	52.65
	.033	.3100	.500	.100	.853	.154	.3125	2.0	QRR-033-8	48.45	QRR-033-8X	52.65
	.033	.3100	.750	.100	.853	.154	.3125	2.0	QRR-033-12	48.45	QRR-033-12X	52.65
NEW	.038	.3100	.250	.100	.853	.153	.3125	2.0	QRR-038-250-310	48.45	QRR-038-250-310X	52.65
	.038	.3100	.375	.100	.853	.154	.3125	2.0	QRR-038-6	48.45	QRR-038-6X	52.65
	.038	.3100	.500	.100	.853	.154	.3125	2.0	QRR-038-8	48.45	QRR-038-8X	52.65
	.038	.3100	.750	.100	.853	.154	.3125	2.0	QRR-038-12	48.45	QRR-038-12X	52.65
NEW	.039	.1800	.250	.030	.590	.086	.1875	1.5	QRR-039-250-180	33.05	QRR-039-250-180X	34.95
NEW	.039	.1800	.500	.030	.590	.086	.1875	1.5	QRR-039-500-180	33.05	QRR-039-500-180X	34.95
NEW	.039	.2450	.250	.050	.853	.120	.2500	2.0	QRR-039-250-245	38.85	QRR-039-250-245X	42.75
NEW	.039	.2450	.500	.050	.853	.120	.2500	2.0	QRR-039-500-245	38.85	QRR-039-500-245X	42.75
NEW	.039	.3700	.375	.100	.853	.182	.3750	2.0	QRR-039-375-370	63.15	QRR-039-375-370X	67.35
	.039	.3700	.500	.100	.853	.182	.3750	2.0	QRR-039-8	63.15	QRR-039-8X	67.35
	.039	.3700	.750	.100	.853	.182	.3750	2.0	QRR-039-12	63.15	QRR-039-12X	67.35
	.039	.3700	1.000	.100	1.353	.182	.3750	2.5	QRR-039-16	63.15	QRR-039-16X	68.95
	.039	.3700	1.250	.100	1.353	.182	.3750	2.5	QRR-039-20	63.15	QRR-039-20X	68.95
NEW	.046	.3100	.500	.100	.853	.153	.3125	2.0	QRR-046-500-310	48.45	QRR-046-500-310X	52.65
NEW	.046	.3100	.750	.100	.853	.153	.3125	2.0	QRR-046-750-310	48.45	QRR-046-750-310X	52.65
NEW	.046	.3700	.375	.100	.853	.182	.3750	2.0	QRR-046-375-370	63.15	QRR-046-375-370X	67.35
	.046	.3700	.500	.100	.853	.182	.3750	2.0	QRR-046-8	63.15	QRR-046-8X	67.35
	.046	.3700	.750	.100	.853	.182	.3750	2.0	QRR-046-12	63.15	QRR-046-12X	67.35
	.046	.3700	1.000	.100	1.353	.182	.3750	2.5	QRR-046-16	63.15	QRR-046-16X	68.95
	.046	.3700	1.250	.100	1.353	.182	.3750	2.5	QRR-046-20	63.15	QRR-046-20X	68.95
	.055	.3700	.500	.100	.853	.182	.3750	2.0	QRR-055-8	63.15	QRR-055-8X	67.35
	.055	.3700	.750	.100	.853	.182	.3750	2.0	QRR-055-12	63.15	QRR-055-12X	67.35
	.055	.3700	1.000	.100	1.353	.182	.3750	2.5	QRR-055-16	63.15	QRR-055-16X	68.95
	.055	.3700	1.250	.100	1.353	.182	.3750	2.5	QRR-055-20	63.15	QRR-055-20X	68.95
	.059	.3700	.500	.100	.853	.182	.3750	2.0	QRR-059-8	63.15	QRR-059-8X	67.35
	.059	.3700	.750	.100	.853	.182	.3750	2.0	QRR-059-12	63.15	QRR-059-12X	67.35
	.059	.3700	1.000	.100	1.353	.182	.3750	2.5	QRR-059-16	63.15	QRR-059-16X	68.95
	.059	.3700	1.250	.100	1.353	.182	.3750	2.5	QRR-059-20	63.15	QRR-059-20X	68.95
NEW	.062	.1800	.250	.030	.590	.086	.1875	1.5	QRR-062-250-180	33.05	QRR-062-250-180X	34.95
NEW	.062	.1800	.500	.030	.590	.086	.1875	1.5	QRR-062-500-180	33.05	QRR-062-500-180X	34.95
NEW	.062	.2450	.250	.050	.853	.120	.2500	2.0	QRR-062-250-245	38.85	QRR-062-250-245X	42.75
NEW	.062	.2450	.500	.050	.853	.120	.2500	2.0	QRR-062-500-245	38.85	QRR-062-500-245X	42.75
NEW	.062	.3100	.500	.100	.853	.153	.3125	2.0	QRR-062-500-310	48.45	QRR-062-500-310X	52.65
NEW	.062	.3100	.750	.100	.853	.153	.3125	2.0	QRR-062-750-310	48.45	QRR-062-750-310X	52.65
NEW	.062	.3700	.250	.100	.853	.182	.3750	2.0	QRR-062-250-370	63.15	QRR-062-250-370X	67.35
NEW	.062	.3700	.375	.100	.853	.182	.3750	2.0	QRR-062-375-370	63.15	QRR-062-375-370X	67.35
	.062	.3700	.500	.100	.853	.182	.3750	2.0	QRR-062-8	63.15	QRR-062-8X	67.35
	.062	.3700	.750	.100	.853	.182	.3750	2.0	QRR-062-12	63.15	QRR-062-12X	67.35
	.062	.3700	1.000	.100	1.353	.182	.3750	2.5	QRR-062-16	63.15	QRR-062-16X	68.95
	.062	.3700	1.250	.100	1.353	.182	.3750	2.5	QRR-062-20	63.15	QRR-062-20X	68.95

See pg 50-62 for quick change holder options

Continued on next page

See pg 26 for miniature sizes

# Quick Change – Grooving Tools

## Retaining Ring – Square (cont.)

**QRR**

Continued from previous page

Width	Minimum Bore Dia.	Maximum Bore Depth	Projection	Length From Holder	Centerline Offset	Shank Dia.	Overall Length	Uncoated		AlTiN Coated	
								Tool #	Price	Tool #	Price
W $^{+.002''}$ $_{-.000''}$	D1	L2 $^{+.030''}$ $_{-.000''}$	P	L4	F	D2 (h6)	L1	Tool #	Price	Tool #	Price
.069	.3700	.500	.100	.853	.182	.3750	2.0	QRR-069-8	63.15	QRR-069-8X	67.35
.069	.3700	.750	.100	.853	.182	.3750	2.0	QRR-069-12	63.15	QRR-069-12X	67.35
.069	.3700	1.000	.100	1.353	.182	.3750	2.5	QRR-069-16	63.15	QRR-069-16X	68.95
.069	.3700	1.250	.100	1.353	.182	.3750	2.5	QRR-069-20	63.15	QRR-069-20X	68.95
.079	.3700	.500	.100	.853	.182	.3750	2.0	QRR-079-8	63.15	QRR-079-8X	67.35
.079	.3700	.750	.100	.853	.182	.3750	2.0	QRR-079-12	63.15	QRR-079-12X	67.35
.079	.3700	1.000	.100	1.353	.182	.3750	2.5	QRR-079-16	63.15	QRR-079-16X	68.95
.079	.3700	1.250	.100	1.353	.182	.3750	2.5	QRR-079-20	63.15	QRR-079-20X	68.95
.087	.3100	.500	.100	.853	.153	.3125	2.0	QRR-087-500-310	48.45	QRR-087-500-310X	52.65
.087	.3100	.750	.100	.853	.153	.3125	2.0	QRR-087-750-310	48.45	QRR-087-750-310X	52.65
.087	.3700	.375	.100	.853	.182	.3750	2.0	QRR-087-375-370	63.15	QRR-087-375-370X	67.35
.087	.3700	.500	.100	.853	.182	.3750	2.0	QRR-087-8	63.15	QRR-087-8X	67.35
.087	.3700	.750	.100	.853	.182	.3750	2.0	QRR-087-12	63.15	QRR-087-12X	67.35
.087	.3700	1.000	.100	1.353	.182	.3750	2.5	QRR-087-16	63.15	QRR-087-16X	68.95
.087	.3700	1.250	.100	1.353	.182	.3750	2.5	QRR-087-20	63.15	QRR-087-20X	68.95
.093	.4950	.750	.150	1.040	.245	.5000	2.5	QRR-093-12	88.50	QRR-093-12X	95.65
.093	.4950	1.000	.150	1.040	.245	.5000	2.5	QRR-093-16	88.50	QRR-093-16X	95.65
.093	.4950	1.250	.150	1.540	.245	.5000	3.0	QRR-093-20	88.50	QRR-093-20X	95.65
.093	.4950	1.500	.150	1.540	.245	.5000	3.0	QRR-093-24	88.50	QRR-093-24X	95.65
.118	.4950	.750	.150	1.040	.245	.5000	2.5	QRR-118-12	88.50	QRR-118-12X	95.65
.118	.4950	1.000	.150	1.040	.245	.5000	2.5	QRR-118-16	88.50	QRR-118-16X	95.65
.118	.4950	1.250	.150	1.540	.245	.5000	3.0	QRR-118-20	88.50	QRR-118-20X	95.65
.118	.4950	1.500	.150	1.540	.245	.5000	3.0	QRR-118-24	88.50	QRR-118-24X	95.65
.125	.3700	.750	.100	.853	.182	.3750	2.0	QRR-125-750-370	63.15	QRR-125-750-370X	67.35
.125	.3700	1.000	.100	1.353	.182	.3750	2.5	QRR-125-1000-370	63.15	QRR-125-1000-370X	68.95
.125	.3700	1.250	.100	1.353	.182	.3750	2.5	QRR-125-1250-370	63.15	QRR-125-1250-370X	68.95
.125	.4950	.750	.150	1.040	.245	.5000	2.5	QRR-125-12	88.50	QRR-125-12X	95.65
.125	.4950	1.000	.150	1.040	.245	.5000	2.5	QRR-125-16	88.50	QRR-125-16X	95.65
.125	.4950	1.250	.150	1.540	.245	.5000	3.0	QRR-125-20	88.50	QRR-125-20X	95.65
.125	.4950	1.500	.150	1.540	.245	.5000	3.0	QRR-125-24	88.50	QRR-125-24X	95.65
.156	.4950	.750	.150	1.040	.245	.5000	2.5	QRR-156-12	88.50	QRR-156-12X	95.65
.156	.4950	1.000	.150	1.040	.245	.5000	2.5	QRR-156-16	88.50	QRR-156-16X	95.65
.156	.4950	1.250	.150	1.540	.245	.5000	3.0	QRR-156-20	88.50	QRR-156-20X	95.65
.156	.4950	1.500	.150	1.540	.245	.5000	3.0	QRR-156-24	88.50	QRR-156-24X	95.65
.187	.4950	.750	.150	1.040	.245	.5000	2.5	QRR-187-12	88.50	QRR-187-12X	95.65
.187	.4950	1.000	.150	1.040	.245	.5000	2.5	QRR-187-16	88.50	QRR-187-16X	95.65
.187	.4950	1.250	.150	1.540	.245	.5000	3.0	QRR-187-20	88.50	QRR-187-20X	95.65
.187	.4950	1.500	.150	1.540	.245	.5000	3.0	QRR-187-24	88.50	QRR-187-24X	95.65
.236	.4950	.750	.150	1.040	.245	.5000	2.5	QRR-236-12	88.50	QRR-236-12X	95.65
.236	.4950	1.000	.150	1.040	.245	.5000	2.5	QRR-236-16	88.50	QRR-236-16X	95.65
.236	.4950	1.250	.150	1.540	.245	.5000	3.0	QRR-236-20	88.50	QRR-236-20X	95.65
.236	.4950	1.500	.150	1.540	.245	.5000	3.0	QRR-236-24	88.50	QRR-236-24X	95.65
.250	.4950	.750	.150	1.040	.245	.5000	2.5	QRR-250-12	88.50	QRR-250-12X	95.65
.250	.4950	1.000	.150	1.040	.245	.5000	2.5	QRR-250-16	88.50	QRR-250-16X	95.65
.250	.4950	1.250	.150	1.540	.245	.5000	3.0	QRR-250-20	88.50	QRR-250-20X	95.65
.250	.4950	1.500	.150	1.540	.245	.5000	3.0	QRR-250-24	88.50	QRR-250-24X	95.65

Quick Change – Grooving Tools

NEW  
NEW  
NEW

NEW  
NEW  
NEW

See pg 50-62 for quick change holder options

See pg 26 for miniature sizes

**QRRC**

**Quick Change - Grooving Tools**  
Retaining Ring - Corner Radius - Right Hand

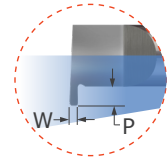
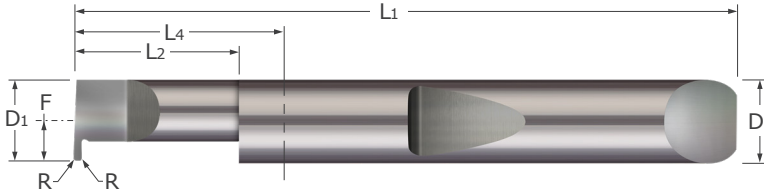

- Designed for generating corner radius retaining ring grooves in bores .180" and larger
- Corner radius designed for extended tool life and finished groove profiling
- Polished split face for improved edge retention and chip evacuation while reducing galling
- Coolant fed enabled shank design
- Proprietary Micro-Quik™ quick change system maximizes productivity through reliable accuracy and locational repeatability
- AlTiN coated option provides added lubricity and increased wear resistance in difficult to machine materials
- Solid carbide ■ CNC ground in the USA

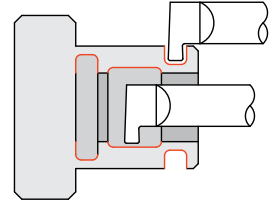

Quick Change - Grooving Tools

	Width	Minimum Bore Dia.	Maximum Bore Depth	Radius	Proj.	Length From Holder	Centerline Offset	Shank Dia.	Overall Length	Uncoated		AlTiN Coated	
	W <sup>+0.011"</sup> / <sub>-.000"</sub>	D1	L2 <sup>+0.030"</sup> / <sub>-.000"</sub>	R <sup>+0.001"</sup> / <sub>-.000"</sub>	P	L4	F	D2 (h6)	L1	Tool #	Price	Tool #	Price
NEW	.017	.1800	.250	.003	.030	.590	.086	.1875	1.5	QRRC3-017-250-180	35.70	QRRC3-017-250-180X	37.60
NEW	.017	.1800	.375	.003	.030	.590	.086	.1875	1.5	QRRC3-017-375-180	35.70	QRRC3-017-375-180X	37.60
NEW	.017	.2450	.250	.003	.050	.853	.120	.2500	2.0	QRRC3-017-250-245	44.65	QRRC3-017-250-245X	48.55
NEW	.017	.2450	.375	.003	.050	.853	.120	.2500	2.0	QRRC3-017-375-245	44.65	QRRC3-017-375-245X	48.55
NEW	.020	.1800	.250	.003	.030	.590	.086	.1875	1.5	QRRC3-020-250-180	35.70	QRRC3-020-250-180X	37.60
NEW	.020	.1800	.375	.003	.030	.590	.086	.1875	1.5	QRRC3-020-375-180	35.70	QRRC3-020-375-180X	37.60
NEW	.020	.2450	.250	.003	.050	.853	.120	.2500	2.0	QRRC3-020-250-245	44.65	QRRC3-020-250-245X	48.55
NEW	.020	.2450	.375	.003	.050	.853	.120	.2500	2.0	QRRC3-020-375-245	44.65	QRRC3-020-375-245X	48.55
NEW	.025	.2450	.250	.003	.050	.853	.120	.2500	2.0	QRRC3-025-250-245	44.65	QRRC3-025-250-245X	48.55
NEW	.025	.2450	.375	.003	.050	.853	.120	.2500	2.0	QRRC3-025-375-245	44.65	QRRC3-025-375-245X	48.55
NEW	.030	.1800	.250	.003	.030	.590	.086	.1875	1.5	QRRC3-030-250-180	35.70	QRRC3-030-250-180X	37.60
NEW	.030	.1800	.500	.003	.030	.590	.086	.1875	1.5	QRRC3-030-500-180	35.70	QRRC3-030-500-180X	37.60
NEW	.030	.2450	.250	.003	.050	.853	.120	.2500	2.0	QRRC3-030-250-245	44.65	QRRC3-030-250-245X	48.55
NEW	.030	.2450	.375	.003	.050	.853	.120	.2500	2.0	QRRC3-030-375-245	44.65	QRRC3-030-375-245X	48.55
NEW	.030	.3100	.500	.003	.100	.853	.153	.3125	2.0	QRRC3-030-500-310	55.65	QRRC3-030-500-310X	59.85
NEW	.030	.3100	.750	.003	.100	.853	.153	.3125	2.0	QRRC3-030-750-310	55.65	QRRC3-030-750-310X	59.85
NEW	.033	.3100	.500	.003	.100	.853	.153	.3125	2.0	QRRC3-033-500-310	55.65	QRRC3-033-500-310X	59.85
NEW	.033	.3100	.750	.003	.100	.853	.153	.3125	2.0	QRRC3-033-750-310	55.65	QRRC3-033-750-310X	59.85
NEW	.038	.3100	.500	.003	.100	.853	.153	.3125	2.0	QRRC3-038-500-310	55.65	QRRC3-038-500-310X	59.85
NEW	.038	.3100	.750	.003	.100	.853	.153	.3125	2.0	QRRC3-038-750-310	55.65	QRRC3-038-750-310X	59.85

	W <sup>+0.002"</sup> / <sub>-.000"</sub>	D1	L2 <sup>+0.030"</sup> / <sub>-.000"</sub>	R <sup>+0.001"</sup> / <sub>-.000"</sub>	P	L4	F	D2 (h6)	L1	Tool #	Price	Tool #	Price
NEW	.039	.3700	.500	.003	.100	.853	.182	.3750	2.0	QRRC3-039-500-370	70.50	QRRC3-039-500-370X	74.70
NEW	.039	.3700	.750	.003	.100	.853	.182	.3750	2.0	QRRC3-039-750-370	70.50	QRRC3-039-750-370X	74.70
NEW	.039	.3700	1.000	.003	.100	1.353	.182	.3750	2.5	QRRC3-039-1000-370	70.50	QRRC3-039-1000-370X	76.30
NEW	.062	.3700	.500	.003	.100	.853	.182	.3750	2.0	QRRC6-062-500-370	70.50	QRRC6-062-500-370X	74.70
NEW	.062	.3700	.500	.006	.100	.853	.182	.3750	2.0	QRRC6-062-500-370	70.50	QRRC6-062-500-370X	74.70
NEW	.062	.3700	.750	.003	.100	.853	.182	.3750	2.0	QRRC6-062-750-370	70.50	QRRC6-062-750-370X	74.70
NEW	.062	.3700	.750	.006	.100	.853	.182	.3750	2.0	QRRC6-062-750-370	70.50	QRRC6-062-750-370X	74.70
NEW	.062	.3700	1.000	.003	.100	1.353	.182	.3750	2.5	QRRC6-062-1000-370	70.50	QRRC6-062-1000-370X	76.30
NEW	.062	.3700	1.000	.006	.100	1.353	.182	.3750	2.5	QRRC6-062-1000-370	70.50	QRRC6-062-1000-370X	76.30

Continued on next page

See pg 50-62 for quick change holder options

# Quick Change – Grooving Tools

**QRR**

## Retaining Ring - Corner Radius - Right Hand (cont.)

Continued from previous page

Width	Minimum Bore Dia.	Maximum Bore Depth	Radius	Proj.	Length From Holder	Centerline Offset	Shank Dia.	Overall Length	Uncoated		AlTiN Coated	
W $\begin{smallmatrix} +.002" \\ -.000" \end{smallmatrix}$	D1	L2 $\begin{smallmatrix} +.030" \\ -.000" \end{smallmatrix}$	R $\begin{smallmatrix} +.001" \\ -.000" \end{smallmatrix}$	P	L4	F	D2 (h6)	L1	Tool #	Price	Tool #	Price
.087	.3700	.500	.003	.100	.853	.182	.3750	2.0	QRR3-087-500-370	70.50	QRR3-087-500-370X	74.70
.087	.3700	.500	.006	.100	.853	.182	.3750	2.0	QRR6-087-500-370	70.50	QRR6-087-500-370X	74.70
.087	.3700	.750	.003	.100	.853	.182	.3750	2.0	QRR3-087-750-370	70.50	QRR3-087-750-370X	74.70
.087	.3700	.750	.006	.100	.853	.182	.3750	2.0	QRR6-087-750-370	70.50	QRR6-087-750-370X	74.70
.087	.3700	1.000	.003	.100	1.353	.182	.3750	2.5	QRR3-087-1000-370	70.50	QRR3-087-1000-370X	76.30
.087	.3700	1.000	.006	.100	1.353	.182	.3750	2.5	QRR6-087-1000-370	70.50	QRR6-087-1000-370X	76.30
.093	.4950	.750	.003	.150	1.040	.245	.5000	2.5	QRR3-093-750-495	96.90	QRR3-093-750-495X	104.05
.093	.4950	.750	.006	.150	1.040	.245	.5000	2.5	QRR6-093-750-495	96.90	QRR6-093-750-495X	104.05
.093	.4950	1.000	.003	.150	1.040	.245	.5000	2.5	QRR3-093-1000-495	96.90	QRR3-093-1000-495X	104.05
.093	.4950	1.000	.006	.150	1.040	.245	.5000	2.5	QRR6-093-1000-495	96.90	QRR6-093-1000-495X	104.05
.125	.4950	.750	.003	.150	1.040	.245	.5000	2.5	QRR3-125-750-495	96.90	QRR3-125-750-495X	104.05
.125	.4950	.750	.006	.150	1.040	.245	.5000	2.5	QRR6-125-750-495	96.90	QRR6-125-750-495X	104.05
.125	.4950	1.000	.003	.150	1.040	.245	.5000	2.5	QRR3-125-1000-495	96.90	QRR3-125-1000-495X	104.05
.125	.4950	1.000	.006	.150	1.040	.245	.5000	2.5	QRR6-125-1000-495	96.90	QRR6-125-1000-495X	104.05

See pg 50-62 for quick change holder options

Quick Change – Grooving Tools



QMFR

Quick Change – Grooving Tools

Full Radius – Miniature

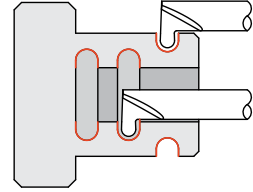
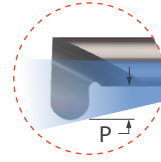
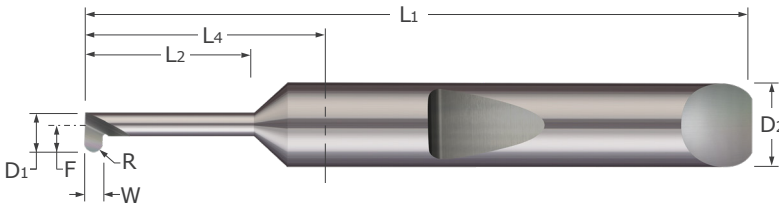

- Designed for generating full radius grooves in bores .080" and larger
- Polished face for improved edge retention and chip evacuation while reducing galling
- On-center neck design
- Coolant fed enabled shank design
- Full radius profile
- Proprietary Micro-Quik™ quick change system maximizes productivity through reliable accuracy and locational repeatability
- AlTiN coated option provides added lubricity and increased wear resistance in difficult to machine materials
- Solid carbide ■ CNC ground in the USA

Quick Change – Grooving Tools

Width	Radius	Minimum Bore Dia.	Maximum Bore Depth	Proj.	Length From Holder	Centerline Offset	Shank Dia.	Overall Length	Uncoated		AlTiN Coated	
									Tool #	Price	Tool #	Price
W $^{+.002"}_{-.000"} R ^{+.001"}_{-.000"} D_1$	R $^{+.001"}_{-.000"} L_2$	D <sub>1</sub>	L <sub>2</sub> $^{+.030"}_{-.000"} P$	P	L <sub>4</sub>	F	D <sub>2</sub> (h6)	L <sub>1</sub>	Tool #	Price	Tool #	Price
.015	.0075	.0800	.250	.025	.590	.053	.1875	1.5	QMFR-015-250-080	43.20	QMFR-015-250-080X	45.10
.015	.0075	.0800	.375	.025	.590	.053	.1875	1.5	QMFR-015-375-080	43.20	QMFR-015-375-080X	45.10
.015	.0075	.0800	.500	.025	.590	.053	.1875	1.5	QMFR-015-500-080	43.20	QMFR-015-500-080X	45.10
.015	.0075	.1000	.250	.030	.590	.065	.1875	1.5	QMFR-015-250-100	43.20	QMFR-015-250-100X	45.10
.015	.0075	.1000	.500	.030	.590	.065	.1875	1.5	QMFR-015-500-100	43.20	QMFR-015-500-100X	45.10
.015	.0075	.1000	.750	.030	1.090	.065	.1875	2.0	QMFR-015-750-100	43.20	QMFR-015-750-100X	45.10
.020	.0100	.0800	.250	.025	.590	.053	.1875	1.5	QMFR-020-250-080	38.85	QMFR-020-250-080X	40.75
.020	.0100	.0800	.375	.025	.590	.053	.1875	1.5	QMFR-020-375-080	38.85	QMFR-020-375-080X	40.75
.020	.0100	.0800	.500	.025	.590	.053	.1875	1.5	QMFR-020-500-080	38.85	QMFR-020-500-080X	40.75
.020	.0100	.1000	.250	.030	.590	.065	.1875	1.5	QMFR-020-250-100	38.85	QMFR-020-250-100X	40.75
.020	.0100	.1000	.500	.030	.590	.065	.1875	1.5	QMFR-020-500-100	38.85	QMFR-020-500-100X	40.75
.020	.0100	.1000	.750	.030	1.090	.065	.1875	2.0	QMFR-020-750-100	38.85	QMFR-020-750-100X	40.75
.020	.0100	.1200	.250	.040	.590	.080	.1875	1.5	QMFR-020-250-120	38.85	QMFR-020-250-120X	40.75
.020	.0100	.1200	.500	.040	.590	.080	.1875	1.5	QMFR-020-500-120	38.85	QMFR-020-500-120X	40.75
.020	.0100	.1200	.750	.040	1.090	.080	.1875	2.0	QMFR-020-750-120	38.85	QMFR-020-750-120X	40.75
.030	.0150	.0800	.250	.025	.590	.053	.1875	1.5	QMFR-030-250-080	38.85	QMFR-030-250-080X	40.75
.030	.0150	.0800	.375	.025	.590	.053	.1875	1.5	QMFR-030-375-080	38.85	QMFR-030-375-080X	40.75
.030	.0150	.0800	.500	.025	.590	.053	.1875	1.5	QMFR-030-500-080	38.85	QMFR-030-500-080X	40.75
.030	.0150	.1000	.250	.030	.590	.065	.1875	1.5	QMFR-030-250-100	38.85	QMFR-030-250-100X	40.75
.030	.0150	.1000	.500	.030	.590	.065	.1875	1.5	QMFR-030-500-100	38.85	QMFR-030-500-100X	40.75
.030	.0150	.1000	.750	.030	1.090	.065	.1875	2.0	QMFR-030-750-100	38.85	QMFR-030-750-100X	40.75
.030	.0150	.1200	.250	.040	.590	.080	.1875	1.5	QMFR-030-250-120	38.85	QMFR-030-250-120X	40.75
.030	.0150	.1200	.500	.040	.590	.080	.1875	1.5	QMFR-030-500-120	38.85	QMFR-030-500-120X	40.75
.030	.0150	.1200	.750	.040	1.090	.080	.1875	2.0	QMFR-030-750-120	38.85	QMFR-030-750-120X	40.75

See pg 50-62 for quick change holder options

# Quick Change – Grooving Tools

QFR

## Full Radius

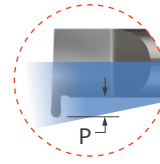
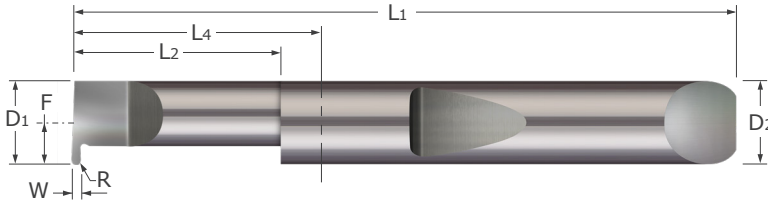

- Designed for generating full radius grooves in bores .180" and larger
- Polished split face for improved edge retention and chip evacuation while reducing galling
- Coolant fed enabled shank design
- Full radius profile
- Proprietary Micro-Quik™ quick change system maximizes productivity through reliable accuracy and locational repeatability
- AlTiN coated option provides added lubricity and increased wear resistance in difficult to machine materials
- Solid carbide ■ CNC ground in the USA

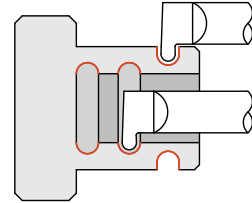

Quick Change – Grooving Tools

Width	Radius	Minimum Bore Dia.	Maximum Bore Depth	Projection	Length From Holder	Centerline Offset	Shank Dia.	Overall Length	Uncoated		AlTiN Coated	
									Tool #	Price	Tool #	Price
W $^{+.002"}_{-.000"}$	R	D1	L2 $^{+.030"}_{-.000"}$	P	L4	F	D2 (h6)	L1	Tool #	Price	Tool #	Price
.017	.0085	.1800	.250	.030	.590	.086	.1875	1.5	QFR-017-4	35.70	QFR-017-4X	37.60
.017	.0085	.1800	.375	.030	.590	.086	.1875	1.5	QFR-017-6	35.70	QFR-017-6X	37.60
.017	.0085	.1800	.500	.030	.590	.086	.1875	1.5	QFR-017-8	35.70	QFR-017-8X	37.60
.017	.0085	.1800	.625	.030	1.090	.086	.1875	2.0	QFR-017-10	35.70	QFR-017-10X	37.60
.020	.0100	.1800	.250	.030	.590	.086	.1875	1.5	QFR-020-4	35.70	QFR-020-4X	37.60
.020	.0100	.1800	.375	.030	.590	.086	.1875	1.5	QFR-020-6	35.70	QFR-020-6X	37.60
.020	.0100	.1800	.500	.030	.590	.086	.1875	1.5	QFR-020-8	35.70	QFR-020-8X	37.60
.020	.0100	.1800	.625	.030	1.090	.086	.1875	2.0	QFR-020-10	35.70	QFR-020-10X	37.60
.025	.0125	.2450	.250	.050	1.090	.120	.2500	2.0	QFR-025-4	44.65	QFR-025-4X	48.55
.025	.0125	.2450	.375	.050	1.090	.120	.2500	2.0	QFR-025-6	44.65	QFR-025-6X	48.55
.025	.0125	.2450	.500	.050	1.090	.120	.2500	2.0	QFR-025-8	44.65	QFR-025-8X	48.55
.025	.0125	.2450	.625	.050	1.090	.120	.2500	2.0	QFR-025-10	44.65	QFR-025-10X	48.55
.030	.0150	.2450	.250	.050	1.090	.120	.2500	2.0	QFR-030-4	44.65	QFR-030-4X	48.55
.030	.0150	.2450	.375	.050	1.090	.120	.2500	2.0	QFR-030-6	44.65	QFR-030-6X	48.55
.030	.0150	.2450	.500	.050	1.090	.120	.2500	2.0	QFR-030-8	44.65	QFR-030-8X	48.55
.030	.0150	.2450	.625	.050	1.090	.120	.2500	2.0	QFR-030-10	44.65	QFR-030-10X	48.55
.033	.0165	.3100	.375	.100	1.090	.154	.3125	2.0	QFR-033-6	55.65	QFR-033-6X	59.85
.033	.0165	.3100	.500	.100	1.090	.154	.3125	2.0	QFR-033-8	55.65	QFR-033-8X	59.85
.033	.0165	.3100	.750	.100	1.090	.154	.3125	2.0	QFR-033-12	55.65	QFR-033-12X	59.85
.038	.0190	.3100	.375	.100	1.090	.154	.3125	2.0	QFR-038-6	55.65	QFR-038-6X	59.85
.038	.0190	.3100	.500	.100	1.090	.154	.3125	2.0	QFR-038-8	55.65	QFR-038-8X	59.85
.038	.0190	.3100	.750	.100	1.090	.154	.3125	2.0	QFR-038-12	55.65	QFR-038-12X	59.85
.039	.0195	.3700	.500	.100	.853	.183	.3750	2.0	QFR-039-8	70.50	QFR-039-8X	74.70
.039	.0195	.3700	.750	.100	.853	.183	.3750	2.0	QFR-039-12	70.50	QFR-039-12X	74.70
.039	.0195	.3700	1.000	.100	1.353	.183	.3750	2.5	QFR-039-16	70.50	QFR-039-16X	76.30
.039	.0195	.3700	1.250	.100	1.353	.183	.3750	2.5	QFR-039-20	70.50	QFR-039-20X	76.30
.046	.0230	.3700	.500	.100	.853	.183	.3750	2.0	QFR-046-8	70.50	QFR-046-8X	74.70
.046	.0230	.3700	.750	.100	.853	.183	.3750	2.0	QFR-046-12	70.50	QFR-046-12X	74.70
.046	.0230	.3700	1.000	.100	1.353	.183	.3750	2.5	QFR-046-16	70.50	QFR-046-16X	76.30
.046	.0230	.3700	1.250	.100	1.353	.183	.3750	2.5	QFR-046-20	70.50	QFR-046-20X	76.30
.055	.0275	.3700	.500	.100	.853	.183	.3750	2.0	QFR-055-8	70.50	QFR-055-8X	74.70
.055	.0275	.3700	.750	.100	.853	.183	.3750	2.0	QFR-055-12	70.50	QFR-055-12X	74.70
.055	.0275	.3700	1.000	.100	1.353	.183	.3750	2.5	QFR-055-16	70.50	QFR-055-16X	76.30
.055	.0275	.3700	1.250	.100	1.353	.183	.3750	2.5	QFR-055-20	70.50	QFR-055-20X	76.30

See pg 50-62 for quick change holder options

Continued on next page

See pg 33 for miniature sizes

## QFR

## Quick Change – Grooving Tools

## Full Radius (cont.)

Continued from previous page

Width	Radius	Minimum Bore Dia.	Maximum Bore Depth	Projection	Length From Holder	Centerline Offset	Shank Dia.	Overall Length	Uncoated		AITIN Coated	
W $\begin{smallmatrix} +.002" \\ -.000" \end{smallmatrix}$	R	D <sub>1</sub>	L <sub>2</sub> $\begin{smallmatrix} +.030" \\ -.000" \end{smallmatrix}$	P	L <sub>4</sub>	F	D <sub>2</sub> (h6)	L <sub>1</sub>	Tool #	Price	Tool #	Price
.059	.0295	.3700	.500	.100	.853	.183	.3750	2.0	QFR-059-8	70.50	QFR-059-8X	74.70
.059	.0295	.3700	.750	.100	.853	.183	.3750	2.0	QFR-059-12	70.50	QFR-059-12X	74.70
.059	.0295	.3700	1.000	.100	1.353	.183	.3750	2.5	QFR-059-16	70.50	QFR-059-16X	76.30
.059	.0295	.3700	1.250	.100	1.353	.183	.3750	2.5	QFR-059-20	70.50	QFR-059-20X	76.30
.062	.0310	.3700	.500	.100	.853	.183	.3750	2.0	QFR-062-8	70.50	QFR-062-8X	74.70
.062	.0310	.3700	.750	.100	.853	.183	.3750	2.0	QFR-062-12	70.50	QFR-062-12X	74.70
.062	.0310	.3700	1.000	.100	1.353	.183	.3750	2.5	QFR-062-16	70.50	QFR-062-16X	76.30
.062	.0310	.3700	1.250	.100	1.353	.183	.3750	2.5	QFR-062-20	70.50	QFR-062-20X	76.30
.069	.0345	.3700	.500	.100	.853	.183	.3750	2.0	QFR-069-8	70.50	QFR-069-8X	74.70
.069	.0345	.3700	.750	.100	.853	.183	.3750	2.0	QFR-069-12	70.50	QFR-069-12X	74.70
.069	.0345	.3700	1.000	.100	1.353	.183	.3750	2.5	QFR-069-16	70.50	QFR-069-16X	76.30
.069	.0345	.3700	1.250	.100	1.353	.183	.3750	2.5	QFR-069-20	70.50	QFR-069-20X	76.30
.079	.0395	.3700	.500	.100	.853	.183	.3750	2.0	QFR-079-8	70.50	QFR-079-8X	74.70
.079	.0395	.3700	.750	.100	.853	.183	.3750	2.0	QFR-079-12	70.50	QFR-079-12X	74.70
.079	.0395	.3700	1.000	.100	1.353	.183	.3750	2.5	QFR-079-16	70.50	QFR-079-16X	76.30
.079	.0395	.3700	1.250	.100	1.353	.183	.3750	2.5	QFR-079-20	70.50	QFR-079-20X	76.30
.087	.0435	.3700	.500	.100	.853	.183	.3750	2.0	QFR-087-8	70.50	QFR-087-8X	74.70
.087	.0435	.3700	.750	.100	.853	.183	.3750	2.0	QFR-087-12	70.50	QFR-087-12X	74.70
.087	.0435	.3700	1.000	.100	1.353	.183	.3750	2.5	QFR-087-16	70.50	QFR-087-16X	76.30
.087	.0435	.3700	1.250	.100	1.353	.183	.3750	2.5	QFR-087-20	70.50	QFR-087-20X	76.30
.093	.0465	.4950	.750	.150	1.040	.245	.5000	2.5	QFR-093-12	96.90	QFR-093-12X	104.05
.093	.0465	.4950	1.000	.150	1.040	.245	.5000	2.5	QFR-093-16	96.90	QFR-093-16X	104.05
.093	.0465	.4950	1.250	.150	1.540	.245	.5000	3.0	QFR-093-20	96.90	QFR-093-20X	104.05
.093	.0465	.4950	1.500	.150	1.540	.245	.5000	3.0	QFR-093-24	96.90	QFR-093-24X	104.05
.118	.0590	.4950	.750	.150	1.040	.245	.5000	2.5	QFR-118-12	96.90	QFR-118-12X	104.05
.118	.0590	.4950	1.000	.150	1.040	.245	.5000	2.5	QFR-118-16	96.90	QFR-118-16X	104.05
.118	.0590	.4950	1.250	.150	1.540	.245	.5000	3.0	QFR-118-20	96.90	QFR-118-20X	104.05
.118	.0590	.4950	1.500	.150	1.540	.245	.5000	3.0	QFR-118-24	96.90	QFR-118-24X	104.05
.125	.0625	.4950	.750	.150	1.040	.245	.5000	2.5	QFR-125-12	96.90	QFR-125-12X	104.05
.125	.0625	.4950	1.000	.150	1.040	.245	.5000	2.5	QFR-125-16	96.90	QFR-125-16X	104.05
.125	.0625	.4950	1.250	.150	1.540	.245	.5000	3.0	QFR-125-20	96.90	QFR-125-20X	104.05
.125	.0625	.4950	1.500	.150	1.540	.245	.5000	3.0	QFR-125-24	96.90	QFR-125-24X	104.05
.156	.0780	.4950	.750	.150	1.040	.245	.5000	2.5			QFR-156-12X	104.05
.156	.0780	.4950	1.000	.150	1.040	.245	.5000	2.5			QFR-156-16X	104.05
.156	.0780	.4950	1.250	.150	1.540	.245	.5000	3.0	QFR-156-20	96.90	QFR-156-20X	104.05
.156	.0780	.4950	1.500	.150	1.540	.245	.5000	3.0	QFR-156-24	96.90	QFR-156-24X	104.05
.187	.0935	.4950	.750	.150	1.040	.245	.5000	2.5	QFR-187-12	96.90	QFR-187-12X	104.05
.187	.0935	.4950	1.000	.150	1.040	.245	.5000	2.5	QFR-187-16	96.90	QFR-187-16X	104.05
.187	.0935	.4950	1.250	.150	1.540	.245	.5000	3.0	QFR-187-20	96.90	QFR-187-20X	104.05
.187	.0935	.4950	1.500	.150	1.540	.245	.5000	3.0	QFR-187-24	96.90	QFR-187-24X	104.05
.236	.1180	.4950	.750	.150	1.040	.245	.5000	2.5	QFR-236-12	96.90	QFR-236-12X	104.05
.236	.1180	.4950	1.000	.150	1.040	.245	.5000	2.5	QFR-236-16	96.90	QFR-236-16X	104.05
.236	.1180	.4950	1.250	.150	1.540	.245	.5000	3.0	QFR-236-20	96.90	QFR-236-20X	104.05
.236	.1180	.4950	1.500	.150	1.540	.245	.5000	3.0	QFR-236-24	96.90	QFR-236-24X	104.05
.250	.1250	.4950	.750	.150	1.040	.245	.5000	2.5	QFR-250-12	96.90	QFR-250-12X	104.05
.250	.1250	.4950	1.000	.150	1.040	.245	.5000	2.5	QFR-250-16	96.90	QFR-250-16X	104.05
.250	.1250	.4950	1.250	.150	1.540	.245	.5000	3.0	QFR-250-20	96.90	QFR-250-20X	104.05
.250	.1250	.4950	1.500	.150	1.540	.245	.5000	3.0	QFR-250-24	96.90	QFR-250-24X	104.05

See pg 50-62 for quick change holder options

See pg 33 for miniature sizes

# Quick Change – Grooving Tools

QUP

## Undercutting – Full Radius

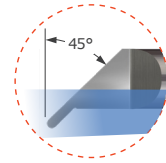
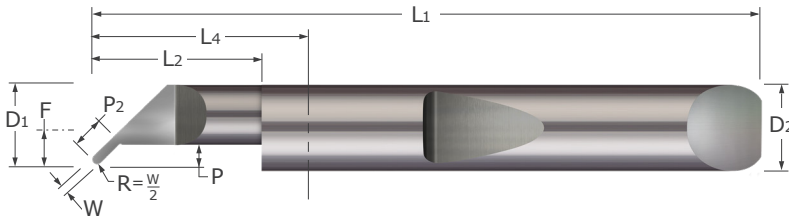

Quick Change – Grooving Tools

- Designed for plunging full radius undercut grooves and profiling
- Polished split face for improved edge retention and chip evacuation while reducing galling
- Full radius profile
- Coolant fed enabled shank design
- Proprietary Micro-Quik™ quick change system maximizes productivity through reliable accuracy and locational repeatability
- AlTiN coated option provides added lubricity and increased wear resistance in difficult to machine materials
- Solid carbide ■ CNC ground in the USA

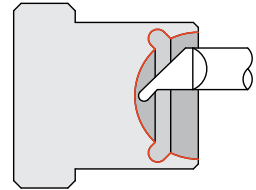

Width	Projection	Angled Projection	Minimum Bore Diameter	Maximum Bore Depth	Length From Holder	Centerline Offset	Shank Diameter	Overall Length	Uncoated		AlTiN Coated	
									Tool #	Price	Tool #	Price
$W \begin{smallmatrix} +.002'' \\ -.000'' \end{smallmatrix}$	P	P <sub>2</sub>	D <sub>1</sub>	$L_2 \begin{smallmatrix} +.030'' \\ -.000'' \end{smallmatrix}$	L <sub>4</sub>	F	D <sub>2</sub> (h6)	L <sub>1</sub>				
.020	.050	.077	.1800	.375	.590	.086	.1875	1.5	QUP-18020-6	41.40	QUP-18020-6X	44.30
.020	.050	.077	.1800	.500	.590	.086	.1875	1.5	QUP-18020-8	41.40	QUP-18020-8X	44.30
.025	.050	.078	.1800	.375	.590	.086	.1875	1.5	QUP-18025-6	41.40	QUP-18025-6X	44.30
.025	.050	.078	.1800	.500	.590	.086	.1875	1.5	QUP-18025-8	41.40	QUP-18025-8X	44.30
.025	.060	.092	.2400	.375	.853	.115	.2500	2.0	QUP-25025-6	44.55	QUP-25025-6X	49.45
.025	.060	.092	.2400	.500	.853	.115	.2500	2.0	QUP-25025-8	44.55	QUP-25025-8X	49.45
.030	.050	.079	.1800	.375	.590	.086	.1875	1.5	QUP-18030-6	41.40	QUP-18030-6X	44.30
.030	.050	.079	.1800	.500	.590	.086	.1875	1.5	QUP-18030-8	41.40	QUP-18030-8X	44.30
.030	.060	.094	.2400	.500	.853	.115	.2500	2.0	QUP-25030-8	44.55	QUP-25030-8X	49.45
.030	.060	.094	.2400	1.000	1.353	.115	.2500	2.5	QUP-25030-16	44.55	QUP-25030-16X	49.45
.062	.083	.136	.3030	1.000	1.353	.147	.3125	2.5	QUP-31062-16	55.90	QUP-31062-16X	62.70
.062	.095	.153	.3650	1.000	1.353	.178	.3750	2.5	QUP-37062-16	71.95	QUP-37062-16X	78.75
.062	.125	.195	.4900	1.500	1.853	.240	.5000	3.0	QUP-50062-24	99.35	QUP-50062-24X	107.55

See pg 50-62 for quick change holder options

## QFG

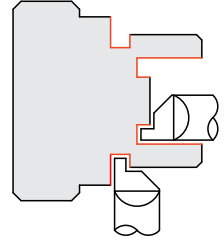
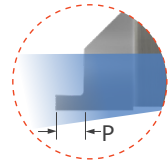
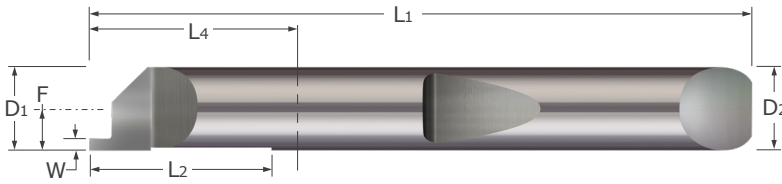
Quick Change – Grooving Tools  
Face Grooving – Square

- Designed for generating square grooves in the face of the part
- Polished split face for improved edge retention and chip evacuation while reducing galling
- Split geometry makes the tool as rigid as possible
- Relief ground along Maximum Bore Depth (L<sub>2</sub>) to avoid interference during deep hole applications
- Coolant fed enabled shank design
- Sharp corner profile
- Proprietary Micro-Quik™ quick change system maximizes productivity through reliable accuracy and locational repeatability
- AlTiN coated option provides added lubricity and increased wear resistance in difficult to machine materials
- Solid carbide ■ CNC ground in the USA

Width	Projection	Minimum Groove Diameter	Maximum Bore Depth	Length From Holder	Centerline Offset	Shank Diameter	Overall Length	Uncoated		AlTiN Coated	
								Tool #	Price	Tool #	Price
W <sup>+0.0021</sup> / <sub>-.0001</sub> "	P <sup>+0.015</sup> / <sub>-.000</sub> "	D <sub>1</sub>	L <sub>2</sub>	L <sub>4</sub>	F	D <sub>2</sub> (h6)	L <sub>1</sub>	Tool #	Price	Tool #	Price
.015	.025	.197	.500	.590	.093	.1875	1.5	QFG-187-015-025	31.15	QFG-187-015-025X	33.05
.015	.025	.260	.750	.853	.125	.2500	2.0	QFG-250-015-025	31.15	QFG-250-015-025X	35.05
.017	.025	.197	.500	.590	.093	.1875	1.5	QFG-187-017-025	31.15	QFG-187-017-025X	33.05
.017	.025	.260	.750	.853	.125	.2500	2.0	QFG-250-017-025	31.15	QFG-250-017-025X	35.05
.020	.025	.197	.500	.590	.093	.1875	1.5	QFG-187-020-025	31.15	QFG-187-020-025X	33.05
.020	.025	.260	.750	.853	.125	.2500	2.0	QFG-250-020-025	31.15	QFG-250-020-025X	35.05
.020	.050	.190	.155	.590	.086	.1875	1.5	QFG-180-020	31.15	QFG-180-020X	33.05
.020	.050	.197	.500	.590	.093	.1875	1.5	QFG-187-020-050	31.15	QFG-187-020-050X	33.05
.020	.050	.240	.190	.853	.105	.2500	2.0	QFG-230-020	31.15	QFG-230-020X	35.05
.020	.050	.260	0.19	.853	.125	.2500	2.0	QFG-250-020	31.15	QFG-250-020X	35.05
.025	.025	.197	.500	.590	.093	.1875	1.5	QFG-187-025-025	31.15	QFG-187-025-025X	33.05
.025	.025	.260	.750	.853	.125	.2500	2.0	QFG-250-025-025	31.15	QFG-250-025-025X	35.05
.025	.050	.197	.500	.590	.093	.1875	1.5	QFG-187-025-050	31.15	QFG-187-025-050X	33.05
.025	.050	.260	.750	.853	.125	.2500	2.0	QFG-250-025-050	31.15	QFG-250-025-050X	35.05
.030	.050	.190	.155	.590	.086	.1875	1.5	QFG-180-030	31.15	QFG-180-030X	33.05
.030	.050	.197	.500	.590	.093	.1875	1.5	QFG-187-030-050	31.15	QFG-187-030-050X	33.05
.030	.050	.240	.190	.853	.105	.2500	2.0	QFG-230-030	31.15	QFG-230-030X	35.05
.030	.050	.260	.190	.853	.125	.2500	2.0	QFG-250-030	31.15	QFG-250-030X	35.05
.030	.050	.322	.225	.853	.188	.3125	2.0	QFG-312-030	42.60	QFG-312-030X	46.80
.030	.050	.385	.750	.853	.188	.3750	2.0	QFG-375-030-050	59.30	QFG-375-030-050X	63.50
.030	.075	.197	.500	.590	.093	.1875	1.5	QFG-187-030-075	31.15	QFG-187-030-075X	33.05
.030	.075	.260	.750	.853	.125	.2500	2.0	QFG-250-030-075	31.15	QFG-250-030-075X	35.05
.039	.050	.260	.750	.853	.125	.2500	2.0	QFG-250-039-050	31.15	QFG-250-039-050X	35.05
.039	.050	.385	.750	.853	.188	.3750	2.0	QFG-375-039-050	59.30	QFG-375-039-050X	63.50
.039	.075	.260	.750	.853	.125	.2500	2.0	QFG-250-039-075	31.15	QFG-250-039-075X	35.05
.040	.050	.197	.500	.590	.093	.1875	1.5	QFG-187-040-050	31.15	QFG-187-040-050X	33.05
.040	.050	.260	.750	.853	.125	.2500	2.0	QFG-250-040-050	31.15	QFG-250-040-050X	35.05
.040	.050	.322	.225	.853	.156	.3125	2.0	QFG-312-040	42.60	QFG-312-040X	46.80
.040	.050	.385	.750	.853	.188	.3750	2.0	QFG-375-040-050	59.30	QFG-375-040-050X	63.50
.040	.075	.197	.500	.590	.093	.1875	1.5	QFG-187-040-075	31.15	QFG-187-040-075X	33.05
.040	.075	.260	.750	.853	.125	.2500	2.0	QFG-250-040-075	31.15	QFG-250-040-075X	35.05

See pg 50-62 for quick change holder options

Continued on next page

# Quick Change – Grooving Tools

QFG

## Face Grooving – Square (cont.)

Continued from previous page

Width	Projection	Minimum Groove Diameter	Maximum Bore Depth	Length From Holder	Centerline Offset	Shank Diameter	Overall Length	Uncoated		AITIN Coated	
W $\begin{smallmatrix} +.002'' \\ -.000'' \end{smallmatrix}$	P $\begin{smallmatrix} +.015'' \\ -.000'' \end{smallmatrix}$	D1	L2	L4	F	D2 (h6)	L1	Tool #	Price	Tool #	Price
.050	.050	.197	.500	.590	.093	.1875	1.5	QFG-187-050-050	31.15	QFG-187-050-050X	33.05
.050	.050	.260	.750	.853	.125	.2500	2.0	QFG-250-050-050	31.15	QFG-250-050-050X	35.05
.050	.050	.385	.750	.853	.188	.3750	2.0	QFG-375-050-050	59.30	QFG-375-050-050X	63.50
.050	.075	.197	.500	.590	.093	.1875	1.5	QFG-187-050-075	31.15	QFG-187-050-075X	33.05
.050	.075	.260	.750	.853	.125	.2500	2.0	QFG-250-050-075	31.15	QFG-250-050-075X	35.05
.050	.075	.322	.750	.853	.156	.3125	2.0	QFG-312-050-075	42.60	QFG-312-050-075X	46.80
.059	.075	.197	.500	.590	.093	.1875	1.5	QFG-187-059-075	31.15	QFG-187-059-075X	33.05
.059	.075	.260	.750	.853	.125	.2500	2.0	QFG-250-059-075	31.15	QFG-250-059-075X	35.05
.059	.075	.385	.750	.853	.188	.3750	2.0	QFG-375-059-075	59.30	QFG-375-059-075X	63.50
.059	.100	.197	.500	.590	.093	.1875	1.5	QFG-187-059-100	31.15	QFG-187-059-100X	33.05
.059	.100	.260	.750	.853	.125	.2500	2.0	QFG-250-059-100	31.15	QFG-250-059-100X	35.05
.062	.075	.197	.500	.590	.093	.1875	1.5	QFG-187-062-075	31.15	QFG-187-062-075X	33.05
.062	.075	.260	.750	.853	.125	.2500	2.0	QFG-250-062-075	31.15	QFG-250-062-075X	35.05
.062	.075	.322	.750	.853	.156	.3125	2.0	QFG-312-062-075	42.60	QFG-312-062-075X	46.80
.062	.075	.385	.750	.853	.188	.3750	2.0	QFG-375-062-075	59.30	QFG-375-062-075X	63.50
.062	.100	.197	.500	.590	.093	.1875	1.5	QFG-187-062-100	31.15	QFG-187-062-100X	33.05
.062	.100	.260	.750	.853	.125	.2500	2.0	QFG-250-062-100	31.15	QFG-250-062-100X	35.05
.062	.100	.322	.225	.853	.156	.3125	2.0	QFG-312-062	42.60	QFG-312-062X	46.80
.062	.100	.385	.260	.853	.188	.3750	2.0	QFG-375-062	59.30	QFG-375-062X	63.50
.062	.100	.480	.335	1.040	.220	.5000	2.5	QFG-470-062	67.10	QFG-470-062X	74.25
.062	.100	.500	.335	1.040	.240	.5000	2.5	QFG-490-062	67.10	QFG-490-062X	74.25
.062	.150	.197	.500	.590	.093	.1875	1.5	QFG-187-062-150	31.15	QFG-187-062-150X	33.05
.062	.150	.260	.750	.853	.125	.2500	2.0	QFG-250-062-150	31.15	QFG-250-062-150X	35.05
.062	.150	.322	.750	.853	.156	.3125	2.0	QFG-312-062-150	42.60	QFG-312-062-150X	46.80
.062	.150	.385	.750	.853	.188	.3750	2.0	QFG-375-062-150	59.30	QFG-375-062-150X	63.50
.078	.100	.260	.750	.853	.125	.2500	2.0	QFG-250-078-100	31.15	QFG-250-078-100X	35.05
.078	.100	.322	.750	.853	.156	.3125	2.0	QFG-312-078-100	42.60	QFG-312-078-100X	46.80
.078	.100	.385	.260	.853	.188	.3750	2.0	QFG-375-078	59.30	QFG-375-078X	63.50
.078	.100	.480	.335	1.040	.220	.5000	2.5	QFG-470-078	67.10	QFG-470-078X	74.25
.078	.100	.500	.335	1.040	.240	.5000	2.5	QFG-490-078	67.10	QFG-490-078X	74.25
.093	.100	.385	.260	.853	.188	.3750	2.0	QFG-375-093	59.30	QFG-375-093X	63.50
.093	.100	.480	.335	1.040	.220	.5000	2.5	QFG-470-093	67.10	QFG-470-093X	74.25
.093	.100	.500	.335	1.040	.240	.5000	2.5	QFG-490-093	67.10	QFG-490-093X	74.25
.093	.150	.322	.750	.853	.156	.3125	2.0	QFG-312-093-150	42.60	QFG-312-093-150X	46.80
.093	.150	.385	.750	.853	.188	.3750	2.0	QFG-375-093-150	59.30	QFG-375-093-150X	63.50
.118	.150	.385	.260	.853	.188	.3750	2.0	QFG-375-118	59.30	QFG-375-118X	63.50
.118	.150	.480	.335	1.040	.220	.5000	2.5	QFG-470-118	67.10	QFG-470-118X	74.25
.118	.150	.500	.335	1.040	.240	.5000	2.5	QFG-490-118	67.10	QFG-490-118X	74.25
.125	.150	.385	.260	.853	.188	.3750	2.0	QFG-375-125	59.30	QFG-375-125X	63.50
.125	.150	.480	.335	1.040	.220	.5000	2.5	QFG-470-125	67.10	QFG-470-125X	74.25
.125	.150	.500	.335	1.040	.240	.5000	2.5	QFG-490-125	67.10	QFG-490-125X	74.25
.125	.250	.385	.750	.853	.188	.3750	2.0	QFG-375-125-250	59.30	QFG-375-125-250X	63.50
.156	.150	.480	.335	1.040	.220	.5000	2.5	QFG-470-156	67.10	QFG-470-156X	74.25
.156	.150	.500	.335	1.040	.240	.5000	2.5	QFG-490-156	67.10	QFG-490-156X	74.25

See pg 50-62 for quick change holder options

Quick Change – Grooving Tools

QFGC

Quick Change – Grooving Tools

Face Grooving – Corner Radius

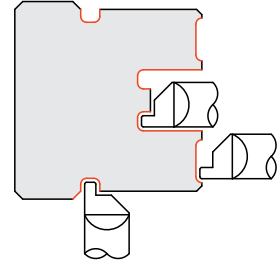
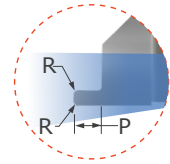
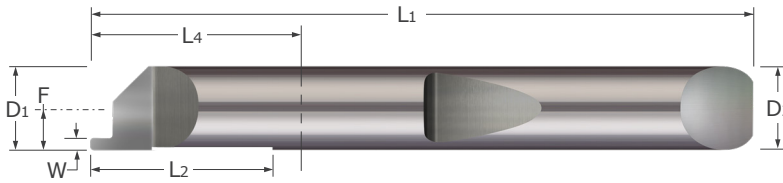

- Designed for generating corner radius grooves within the face of the part
- Polished split face for improved edge retention and chip evacuation while reducing galling
- Split geometry makes the tool as rigid as possible
- Relief ground along Maximum Bore Depth (L2) to avoid interference during deep hole applications
- Coolant fed enabled shank design
- Corner radius profile
- Proprietary Micro-Quik™ quick change system maximizes productivity through reliable accuracy and locational repeatability
- AlTiN coated option provides added lubricity and increased wear resistance in difficult to machine materials
- Solid carbide ■ CNC ground in the USA

Quick Change – Grooving Tools

Width	Projection	Minimum Groove Diameter	Radius	Maximum Bore Depth	Length From Holder	Centerline Offset	Shank Diameter	Overall Length	Uncoated		AlTiN Coated	
									Tool #	Price	Tool #	Price
W $\begin{matrix} +.002" \\ -.000" \end{matrix}$	P $\begin{matrix} +.015" \\ -.000" \end{matrix}$	D1	R $\begin{matrix} +.001" \\ -.001" \end{matrix}$	L2	L4	F	D2 (h6)	L1	Tool #	Price	Tool #	Price
.015	.025	.197	.003	.500	.590	.093	.1875	1.5	QFGC3-187-015-025	28.70	QFGC3-187-015-025X	31.60
.015	.025	.260	.003	.750	.853	.125	.2500	2.0	QFGC3-250-015-025	33.50	QFGC3-250-015-025X	38.40
.017	.025	.197	.003	.500	.590	.093	.1875	1.5	QFGC3-187-017-025	28.70	QFGC3-187-017-025X	31.60
.017	.025	.260	.003	.750	.853	.125	.2500	2.0	QFGC3-250-017-025	33.50	QFGC3-250-017-025X	38.40
.020	.025	.197	.003	.500	.590	.093	.1875	1.5	QFGC3-187-020-025	28.70	QFGC3-187-020-025X	31.60
.020	.025	.260	.003	.750	.853	.125	.2500	2.0	QFGC3-250-020-025	33.50	QFGC3-250-020-025X	38.40
.025	.025	.197	.003	.500	.590	.093	.1875	1.5	QFGC3-187-025-025	28.70	QFGC3-187-025-025X	31.60
.025	.025	.260	.003	.750	.853	.125	.2500	2.0	QFGC3-250-025-025	33.50	QFGC3-250-025-025X	38.40
.030	.050	.197	.003	.500	.590	.093	.1875	1.5	QFGC3-187-030-050	28.70	QFGC3-187-030-050X	31.60
.030	.050	.260	.003	.750	.853	.125	.2500	2.0	QFGC3-250-030-050	33.50	QFGC3-250-030-050X	38.40
.030	.050	.322	.003	.750	.853	.156	.3125	2.0	QFGC3-312-030-050	44.00	QFGC3-312-030-050X	50.80
.030	.050	.385	.003	.750	.853	.188	.3750	2.0	QFGC3-375-030-050	59.80	QFGC3-375-030-050X	66.60
.039	.050	.197	.003	.500	.590	.093	.1875	1.5	QFGC3-187-039-050	28.70	QFGC3-187-039-050X	31.60
.039	.050	.260	.003	.750	.853	.125	.2500	2.0	QFGC3-250-039-050	33.50	QFGC3-250-039-050X	38.40
.039	.050	.385	.003	.750	.853	.188	.3750	2.0	QFGC3-375-039-050	59.80	QFGC3-375-039-050X	66.60
.040	.050	.197	.003	.500	.590	.093	.1875	1.5	QFGC3-187-040-050	28.70	QFGC3-187-040-050X	31.60
.040	.050	.260	.003	.750	.853	.125	.2500	2.0	QFGC3-250-040-050	33.50	QFGC3-250-040-050X	38.40
.040	.050	.322	.003	.750	.853	.156	.3125	2.0	QFGC3-312-040-050	44.00	QFGC3-312-040-050X	50.80
.040	.050	.385	.003	.750	.853	.188	.3750	2.0	QFGC3-375-040-050	59.80	QFGC3-375-040-050X	66.60
.050	.050	.197	.003	.500	.590	.093	.1875	1.5	QFGC3-187-050-050	28.70	QFGC3-187-050-050X	31.60
.050	.050	.260	.003	.750	.853	.125	.2500	2.0	QFGC3-250-050-050	33.50	QFGC3-250-050-050X	38.40
.050	.050	.322	.003	.750	.853	.156	.3125	2.0	QFGC3-312-050-050	44.00	QFGC3-312-050-050X	50.80
.050	.050	.385	.003	.750	.853	.188	.3750	2.0	QFGC3-375-050-050	59.80	QFGC3-375-050-050X	66.60
.059	.075	.385	.003	.750	.853	.188	.3750	2.0	QFGC3-375-059-075	59.80	QFGC3-375-059-075X	66.60

Continued on next page

See pg 50-62 for quick change holder options

# Quick Change – Grooving Tools

## Face Grooving – Corner Radius (cont.)

QFGC

Continued from previous page

W	P	Minimum Groove Diameter	Radius	Maximum Bore Depth	Length From Holder	Centerline Offset	Shank Diameter	Overall Length	Uncoated		AlTiN Coated	
									Tool #	Price	Tool #	Price
.062	.075	.197	.003	.500	.590	.093	.1875	1.5	QFGC3-187-062-075	28.70	QFGC3-187-062-075X	31.60
.062	.075	.260	.003	.750	.853	.125	.2500	2.0	QFGC3-250-062-075	33.50	QFGC3-250-062-075X	38.40
.062	.075	.322	.003	.750	.853	.156	.3125	2.0	QFGC3-312-062-075	44.00	QFGC3-312-062-075X	50.80
.062	.075	.385	.003	.750	.853	.188	.3750	2.0	QFGC3-375-062-075	59.80	QFGC3-375-062-075X	66.60
.062	.100	.197	.003	.500	.590	.093	.1875	1.5	QFGC3-187-062-100	28.70	QFGC3-187-062-100X	31.60
.062	.100	.260	.003	.750	.853	.125	.2500	2.0	QFGC3-250-062-100	33.50	QFGC3-250-062-100X	38.40
.078	.100	.260	.003	.750	.853	.125	.2500	2.0	QFGC3-250-078-100	33.50	QFGC3-250-078-100X	38.40
.078	.100	.322	.003	.750	.853	.156	.3125	2.0	QFGC3-312-078-100	44.00	QFGC3-312-078-100X	50.80
.078	.100	.385	.003	.750	.853	.188	.3750	2.0	QFGC3-375-078-100	59.80	QFGC3-375-078-100X	66.60
.093	.100	.385	.006	.750	.853	.188	.3750	2.0	QFGC6-375-093-100	59.80	QFGC6-375-093-100X	66.60
.093	.150	.322	.006	.750	.853	.156	.3125	2.0	QFGC6-312-093-150	44.00	QFGC6-312-093-150X	50.80
.118	.150	.385	.006	.750	.853	.188	.3750	2.0	QFGC6-375-118-150	59.80	QFGC6-375-118-150X	66.60
.125	.100	.385	.006	.750	.853	.188	.3750	2.0	QFGC6-375-125-100	59.80	QFGC6-375-125-100X	66.60

See pg 50-62 for quick change holder options

Quick Change – Grooving Tools



QFGF

Quick Change – Grooving Tools  
Face Grooving – Full Radius

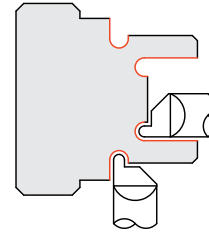
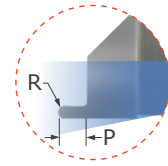
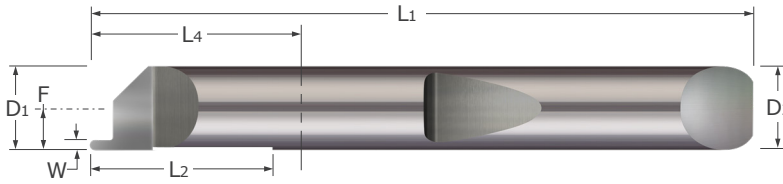

- Designed for generating full radius grooves in the face of the part
- Polished split face for improved edge retention and chip evacuation while reducing galling
- Split geometry makes the tool as rigid as possible
- Relief ground along Maximum Bore Depth (L<sub>2</sub>) to avoid interference during deep hole applications
- Coolant fed enabled shank design
- Full radius profile
- Proprietary Micro-Quik™ quick change system maximizes productivity through reliable accuracy and locational repeatability
- AlTiN coated option provides added lubricity and increased wear resistance in difficult to machine materials
- Solid carbide ■ CNC ground in the USA

Quick Change – Grooving Tools

Width	Radius	Projection	Minimum Groove Diameter	Maximum Bore Depth	Length From Holder	Centerline Offset	Shank Diameter	Overall Length	Uncoated		AlTiN Coated		
									Tool #	Price	Tool #	Price	
W <sup>+0.002"</sup> <sub>-.000"</sub>	R	P	<sup>+0.015"</sup> <sub>-.000"</sub>	D <sub>1</sub>	L <sub>2</sub>	L <sub>4</sub>	F	D <sub>2</sub> (h6)	L <sub>1</sub>	Tool #	Price	Tool #	Price
.015	.008	.025	.197	.500	.590	.093	.1875	1.5	QFGF-187-015-025	28.90	QFGF-187-015-025X	31.80	
.015	.008	.025	.260	.750	.853	.125	.2500	2.0	QFGF-250-015-025	32.30	QFGF-250-015-025X	37.20	
.017	.009	.025	.197	.500	.590	.093	.1875	1.5	QFGF-187-017-025	28.90	QFGF-187-017-025X	31.80	
.017	.009	.025	.260	.750	.853	.125	.2500	2.0	QFGF-250-017-025	32.30	QFGF-250-017-025X	37.20	
.020	.010	.050	.190	.155	.590	.086	.1875	1.5	QFGF-180-020	28.90	QFGF-180-020X	31.80	
.020	.010	.050	.197	.500	.590	.093	.1875	1.5	QFGF-187-020-050	28.90	QFGF-187-020-050X	31.80	
.020	.010	.050	.240	.190	.853	.105	.2500	2.0	QFGF-230-020	32.30	QFGF-230-020X	37.20	
.020	.010	.050	.260	.190	.853	.125	.2500	2.0	QFGF-250-020	32.30	QFGF-250-020X	37.20	
.025	.013	.050	.197	.500	.590	.093	.1875	1.5	QFGF-187-025-050	28.90	QFGF-187-025-050X	31.80	
.025	.013	.050	.260	.750	.853	.125	.2500	2.0	QFGF-250-025-050	32.30	QFGF-250-025-050X	37.20	
.030	.015	.050	.190	.155	.590	.086	.1875	1.5	QFGF-180-030	28.90	QFGF-180-030X	31.80	
.030	.015	.050	.197	.500	.590	.093	.1875	1.5	QFGF-187-030-050	28.90	QFGF-187-030-050X	31.80	
.030	.015	.050	.260	.190	.853	.125	.2500	2.0	QFGF-250-030	32.30	QFGF-250-030X	37.20	
.039	.020	.075	.197	.500	.590	.093	.1875	1.5	QFGF-187-039-075	28.90	QFGF-187-039-075X	31.80	
.039	.020	.075	.260	.750	.853	.125	.2500	2.0	QFGF-250-039-075	32.30	QFGF-250-039-075X	37.20	
.040	.020	.050	.260	.190	.853	.125	.2500	2.0	QFGF-250-040	32.30	QFGF-250-040X	37.20	
.040	.020	.075	.197	.500	.590	.093	.1875	1.5	QFGF-187-040-075	28.90	QFGF-187-040-075X	31.80	
.040	.020	.075	.260	.750	.853	.125	.2500	2.0	QFGF-250-040-075	32.30	QFGF-250-040-075X	37.20	
.050	.025	.050	.322	.225	.853	.156	.3125	2.0	QFGF-312-050	44.05	QFGF-312-050X	50.85	
.050	.025	.075	.197	.500	.590	.093	.1875	1.5	QFGF-187-050-075	28.90	QFGF-187-050-075X	31.80	
.050	.025	.075	.260	.750	.853	.125	.2500	2.0	QFGF-250-050-075	32.30	QFGF-250-050-075X	37.20	
.062	.031	.075	.322	.750	.853	.156	.3125	2.0	QFGF-312-062-075	44.05	QFGF-312-062-075X	50.85	
.062	.031	.075	.385	.750	.853	.188	.3750	2.0	QFGF-375-062-075	61.00	QFGF-375-062-075X	66.20	
.062	.031	.100	.197	.500	.590	.093	.1875	1.5	QFGF-187-062-100	28.90	QFGF-187-062-100X	31.80	
.062	.031	.100	.260	.750	.853	.125	.2500	2.0	QFGF-250-062-100	32.30	QFGF-250-062-100X	37.20	
.062	.031	.100	.322	.225	.853	.156	.3125	2.0	QFGF-312-062	44.05	QFGF-312-062X	50.85	
.062	.031	.100	.385	.260	.853	.188	.3750	2.0	QFGF-375-062	61.00	QFGF-375-062X	66.20	
.078	.039	.100	.385	.260	.853	.188	.3750	2.0	QFGF-375-078	61.00	QFGF-375-078X	66.20	
.093	.047	.100	.385	.260	.853	.188	.3750	2.0	QFGF-375-093	61.00	QFGF-375-093X	66.20	
.125	.063	.150	.385	.260	.853	.188	.3750	2.0	QFGF-375-125	61.00	QFGF-375-125X	66.20	

See pg 50-62 for quick change holder options

# Quick Change – Threading Tools

## UN Threads – Single Point – Miniature

QIT

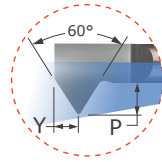
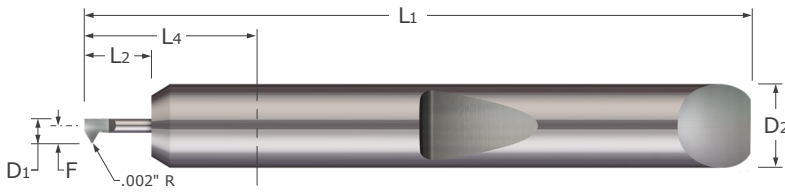

Quick Change – Threading Tools

- Designed for threading in bores .035" and larger
- Able to cut multiple thread pitches (ANSI, UN, & Metric 60°) with one tool
- Polished split face for improved edge retention and chip evacuation while reducing galling
- On-center neck design
- .002" tip radius
- Coolant fed enabled shank design
- Proprietary Micro-Quik™ quick change system maximizes productivity through reliable accuracy and locational repeatability
- AlTiN coated option provides added lubricity and increased wear resistance in difficult to machine materials
- Solid carbide ■ CNC ground in the USA

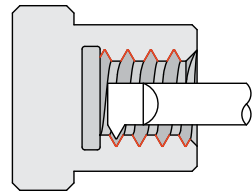

Threads Per Inch	Minimum Bore Diameter	Maximum Bore Depth	Point Offset	Projection	Length From Holder	Centerline Offset	Shank Dia.	Overall Length	Uncoated		AlTiN Coated	
									Tool #	Price	Tool #	Price
TPI*	D1	L2	$Y \begin{smallmatrix} +.030'' \\ -.000'' \end{smallmatrix}$	P	L4	F	D2 (h6)	L1				
56-80	.0350	.075	.012	.015	.590	.025	.1875	1.5	QIT-035075	45.35	QIT-035075X	47.25
56-80	.0350	.100	.012	.015	.590	.025	.1875	1.5	QIT-035100	45.35	QIT-035100X	47.25
56-80	.0350	.150	.012	.015	.590	.025	.1875	1.5	QIT-035150	45.35	QIT-035150X	47.25
56-80	.0400	.075	.015	.020	.590	.030	.1875	1.5	QIT-040075	45.35	QIT-040075X	47.25
56-80	.0400	.100	.015	.020	.590	.030	.1875	1.5	QIT-040100	45.35	QIT-040100X	47.25
56-80	.0400	.150	.015	.020	.590	.030	.1875	1.5	QIT-040150	45.35	QIT-040150X	47.25
48-80	.0500	.100	.015	.020	.590	.035	.1875	1.5	QIT-050100	38.35	QIT-050100X	40.25
48-80	.0500	.150	.015	.020	.590	.035	.1875	1.5	QIT-050150	38.35	QIT-050150X	40.25
48-80	.0500	.200	.015	.020	.590	.035	.1875	1.5	QIT-050200	38.35	QIT-050200X	40.25

\*Thread range based on height of sharp thread (.866P) and projection.

See pg 50-62 for quick change holder options

QIT

Quick Change – Threading Tools  
UN Threads – Single Point

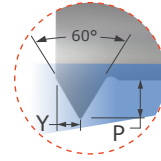
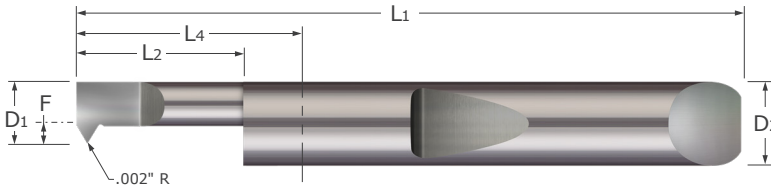

- Designed for threading in bores .060" and larger
- Able to cut multiple thread pitches (ANSI, UN, & Metric 60°) with one tool
- Polished split face for improved edge retention and chip evacuation while reducing galling
- Split geometry makes the tool as rigid as possible
- .002" tip radius
- Coolant fed enabled shank design
- Proprietary Micro-Quik™ quick change system maximizes productivity through reliable accuracy and locational repeatability
- AlTiN coated option provides added lubricity and increased wear resistance in difficult to machine materials
- Solid carbide ■ CNC ground in the USA

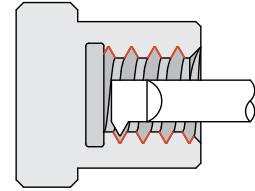

Quick Change – Threading Tools

Threads Per Inch	Minimum Bore Diameter	Maximum Bore Depth	Point Offset	Projection	Length From Holder	Centerline Offset	Shank Dia.	Overall Length	Uncoated		AlTiN Coated	
									Tool #	Price	Tool #	Price
TPI*	D1	L2 $\begin{matrix} +.030" \\ -.000" \end{matrix}$	Y $\begin{matrix} +.002" \\ -.000" \end{matrix}$	P	L4	F	D2 (h6)	L1				
40-80	.0600	.200	.015	.020	.590	-.034	.1875	1.5	QIT-060200	38.35	QIT-060200X	40.25
40-80	.0600	.250	.015	.020	.590	-.034	.1875	1.5	QIT-060250	38.35	QIT-060250X	40.25
40-80	.0600	.300	.015	.020	.590	-.034	.1875	1.5	QIT-060300	38.35	QIT-060300X	40.25
32-76	.0800	.250	.015	.020	.590	-.014	.1875	1.5	QIT-080250	38.35	QIT-080250X	40.25
32-76	.0800	.350	.015	.020	.590	-.014	.1875	1.5	QIT-080350	38.35	QIT-080350X	40.25
32-76	.0800	.500	.015	.020	.590	-.014	.1875	1.5	QIT-080500	38.35	QIT-080500X	40.25
32-64	.1000	.250	.018	.025	.590	.006	.1875	1.5	QIT-100250	38.35	QIT-100250X	40.25
32-64	.1000	.350	.018	.025	.590	.006	.1875	1.5	QIT-100350	38.35	QIT-100350X	40.25
32-64	.1000	.500	.018	.025	.590	.006	.1875	1.5	QIT-100500	38.35	QIT-100500X	40.25
32-64	.1000	.600	.018	.025	1.090	.006	.1875	2.0	QIT-100600	38.35	QIT-100600X	40.25
32-64	.1100	.250	.020	.030	.590	.016	.1875	1.5	QIT-110250	38.35	QIT-110250X	40.25
32-64	.1100	.400	.020	.030	.590	.016	.1875	1.5	QIT-110400	38.35	QIT-110400X	40.25
32-64	.1100	.500	.020	.030	.590	.016	.1875	1.5	QIT-110500	38.35	QIT-110500X	40.25
32-64	.1100	.600	.020	.030	1.090	.016	.1875	2.0	QIT-110600	38.35	QIT-110600X	40.25
32-64	.1100	.750	.020	.030	1.090	.016	.1875	2.0	QIT-110750	38.35	QIT-110750X	40.25
24-56	.1200	.250	.020	.030	.590	.026	.1875	1.5	QIT-120250	38.35	QIT-120250X	40.25
24-56	.1200	.400	.020	.030	.590	.026	.1875	1.5	QIT-120400	38.35	QIT-120400X	40.25
24-56	.1200	.500	.020	.030	.590	.026	.1875	1.5	QIT-120500	38.35	QIT-120500X	40.25
24-56	.1200	.600	.020	.030	1.090	.026	.1875	2.0	QIT-120600	38.35	QIT-120600X	40.25
24-56	.1200	.750	.020	.030	1.090	.026	.1875	2.0	QIT-120750	38.35	QIT-120750X	40.25
20-56	.1400	.250	.023	.035	.590	.046	.1875	1.5	QIT-140250	38.35	QIT-140250X	40.25
20-56	.1400	.400	.023	.035	.590	.046	.1875	1.5	QIT-140400	38.35	QIT-140400X	40.25
20-56	.1400	.500	.023	.035	.590	.046	.1875	1.5	QIT-140500	38.35	QIT-140500X	40.25
20-56	.1400	.750	.023	.035	.590	.046	.1875	2.0	QIT-140750	38.35	QIT-140750X	40.25
20-56	.1600	.250	.029	.040	.590	.066	.1875	1.5	QIT-160250	38.35	QIT-160250X	40.25
20-56	.1600	.400	.029	.040	.590	.066	.1875	1.5	QIT-160400	38.35	QIT-160400X	40.25
20-56	.1600	.500	.029	.040	.590	.066	.1875	1.5	QIT-160500	38.35	QIT-160500X	40.25
20-56	.1600	.750	.029	.040	1.090	.066	.1875	2.0	QIT-160750	38.35	QIT-160750X	40.25
20-56	.1600	1.000	.029	.040	1.090	.066	.1875	2.0	QIT-1601000	38.35	QIT-1601000X	40.25

\*Thread range based on height of sharp thread (.866P) and projection.

Continued on next page

See pg 50-62 for quick change holder options

# Quick Change – Threading Tools

QIT

## UN Threads – Single Point (cont.)

Continued from previous page

Threads Per Inch	Minimum Bore Diameter	Maximum Bore Depth	Point Offset	Projection	Length From Holder	Centerline Offset	Shank Dia.	Overall Length	Uncoated		AITiN Coated	
									Tool #	Price	Tool #	Price
TPI*	D1	L2 <sup>+0.030"</sup> / <sub>-.000"</sub>	Y <sup>+0.002"</sup> / <sub>-.000"</sub>	P	L4	F	D2 (h6)	L1				
18-56	.1800	.350	.029	.040	.853	.055	.2500	2.0	QIT-180350	40.95	QIT-180350X	44.85
18-56	.1800	.500	.029	.040	.853	.055	.2500	2.0	QIT-180500	40.95	QIT-180500X	44.85
18-56	.1800	.750	.029	.040	.853	.055	.2500	2.0	QIT-180750	40.95	QIT-180750X	44.85
18-56	.1800	1.000	.029	.040	1.353	.055	.2500	2.5	QIT-1801000	40.95	QIT-1801000X	44.85
16-40	.2000	.400	.032	.045	.853	.075	.2500	2.0	QIT-200400	40.95	QIT-200400X	44.85
16-40	.2000	.600	.032	.045	.853	.075	.2500	2.0	QIT-200600	40.95	QIT-200600X	44.85
16-40	.2000	.750	.032	.045	.853	.075	.2500	2.0	QIT-200750	40.95	QIT-200750X	44.85
16-40	.2000	1.000	.032	.045	1.353	.075	.2500	2.5	QIT-2001000	40.95	QIT-2001000X	44.85
14-40	.2300	.400	.038	.055	.853	.074	.3125	2.0	QIT-230400	51.25	QIT-230400X	55.45
14-40	.2300	.600	.038	.055	.853	.074	.3125	2.0	QIT-230600	51.25	QIT-230600X	55.45
14-40	.2300	.750	.038	.055	.853	.074	.3125	2.0	QIT-230750	51.25	QIT-230750X	55.45
14-40	.2300	1.000	.038	.055	1.353	.074	.3125	2.5	QIT-2301000	51.25	QIT-2301000X	57.05
14-40	.2300	1.500	.038	.055	1.856	.074	.3125	3.0	QIT-2301500	58.05	QIT-2301500X	63.85
12-40	.2900	.500	.046	.070	.853	.134	.3125	2.0	QIT-290500	51.25	QIT-290500X	55.45
12-40	.2900	.750	.046	.070	.853	.134	.3125	2.0	QIT-290750	51.25	QIT-290750X	55.45
12-40	.2900	1.000	.046	.070	1.353	.134	.3125	2.5	QIT-2901000	51.25	QIT-2901000X	55.45
12-40	.2900	1.250	.046	.070	1.353	.134	.3125	2.5	QIT-2901250	51.25	QIT-2901250X	57.05
12-40	.2900	1.750	.046	.070	1.856	.134	.3125	3.0	QIT-2901750	58.05	QIT-2901750X	63.85
10-32	.3200	.500	.049	.075	.853	.133	.3750	2.0	QIT-320500	66.75	QIT-320500X	70.95
10-32	.3200	.750	.049	.075	.853	.133	.3750	2.0	QIT-320750	66.75	QIT-320750X	70.95
10-32	.3200	1.000	.049	.075	1.353	.133	.3750	2.5	QIT-3201000	66.75	QIT-3201000X	72.55
10-32	.3200	1.250	.049	.075	1.353	.133	.3750	2.5	QIT-3201250	66.75	QIT-3201250X	72.55
10-32	.3200	1.800	.049	.075	1.853	.133	.3750	3.0	QIT-3201800	73.50	QIT-3201800X	79.30
10-32	.3600	.500	.055	.085	.853	.173	.3750	2.0	QIT-360500	66.75	QIT-360500X	70.95
10-32	.3600	.750	.055	.085	.853	.173	.3750	2.0	QIT-360750	66.75	QIT-360750X	70.95
10-32	.3600	1.000	.055	.085	1.353	.173	.3750	2.5	QIT-3601000	66.75	QIT-3601000X	72.55
10-32	.3600	1.250	.055	.085	1.353	.173	.3750	2.5	QIT-3601250	66.75	QIT-3601250X	72.55
10-32	.3600	1.800	.055	.085	1.853	.173	.3750	3.0	QIT-3601800	73.50	QIT-3601800X	79.30
6-24	.4600	.750	.078	.120	1.040	.210	.5000	2.5	QIT-460750	93.60	QIT-460750X	100.75
6-24	.4600	1.500	.078	.120	1.540	.210	.5000	3.0	QIT-4601500	93.60	QIT-4601500X	100.75
6-24	.4600	2.000	.078	.120	2.040	.210	.5000	3.5	QIT-4602000	102.10	QIT-4602000X	111.40
6-24	.4900	.750	.078	.120	1.040	.240	.5000	2.5	QIT-490750	93.60	QIT-490750X	100.75
6-24	.4900	1.500	.078	.120	1.540	.240	.5000	3.0	QIT-4901500	93.60	QIT-4901500X	100.75
6-24	.4900	2.000	.078	.120	2.040	.240	.5000	3.5	QIT-4902000	102.10	QIT-4902000X	111.40

\*Thread range based on height of sharp thread (.866P) and projection.

See pg 50-62 for quick change holder options

Quick Change – Threading Tools

QSPD

Quick Change – Holmaking Tools  
Spotting Drills

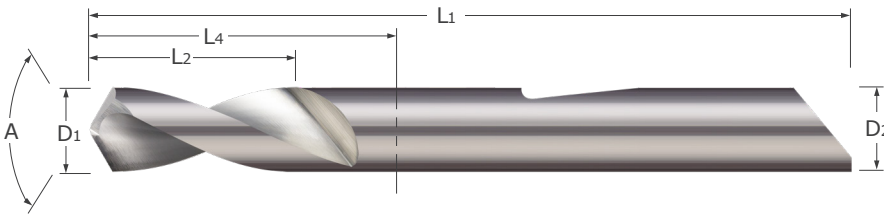

- Designed for spot drilling
- Available in 90°, 120°, and 140° included angles
- Can be utilized for countersinking and chamfering existing holes
- Narrow web thickness allows for spotting small diameter holes
- Point geometry designed for self-centering
- Coolant fed enabled shank design
- Proprietary Micro-Quik™ quick change system maximizes productivity through reliable accuracy and locational repeatability
- AlTiN coated option provides added lubricity and increased wear resistance in difficult to machine materials
- Solid carbide ■ CNC ground in the USA

Point Geometry Types

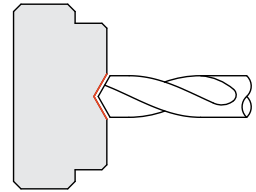
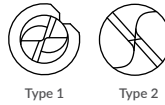

Quick Change – Holmaking Tools

Included Angle	Drill Diameter	Flute Length	Web Thickness	Type	Length From Holder	Shank Diameter	Overall Length	Uncoated		AlTiN Coated	
								Tool #	Price	Tool #	Price
A	D1 $\begin{matrix} +.0000" \\ -.0005" \end{matrix}$	L2 $\begin{matrix} +.010" \\ -.000" \end{matrix}$	$\begin{matrix} +.001" \\ -.001" \end{matrix}$		L4	D2 (h6)	L1				
90°	.0200	.060	.002	I	.590	.1875	1.5	QSPD-020-090	36.40	QSPD-020-090X	38.30
	.0250	.075	.002	I	.590	.1875	1.5	QSPD-025-090	32.35	QSPD-025-090X	34.25
	.0300	.090	.003	I	.590	.1875	1.5	QSPD-030-090	32.35	QSPD-030-090X	34.25
	.0350	.105	.003	I	.590	.1875	1.5	QSPD-035-090	32.35	QSPD-035-090X	34.25
	.0400	.120	.004	I	.590	.1875	1.5	QSPD-040-090	28.15	QSPD-040-090X	30.05
	.0450	.135	.004	I	.590	.1875	1.5	QSPD-045-090	28.15	QSPD-045-090X	30.05
	.0500	.150	.005	I	.590	.1875	1.5			QSPD-050-090X	30.05
	.0600	.180	.006	I	.590	.1875	1.5	QSPD-060-090	28.15	QSPD-060-090X	30.05
	.0900	.270	.006	I	.590	.1875	1.5	QSPD-090-090	28.15	QSPD-090-090X	30.05
	.1181	.354	.008	I	.590	.1875	1.5	QSPD-118-090	28.15	QSPD-118-090X	30.05
	.1250	.375	.010	I	.590	.1875	1.5	QSPD-125-090	28.15	QSPD-125-090X	30.05
	.1875	.625	.005	II	1.090	.1875	2.0	QSPD-187-090	28.15	QSPD-187-090X	30.05
	.2500	.750	.005	II	1.353	.2500	2.5	QSPD-250-090	33.15	QSPD-250-090X	37.05
	.3750	1.000	.005	II	1.353	.3750	2.5	QSPD-375-090	44.65	QSPD-375-090X	50.45
120°	.0150	.045	.002	I	.590	.1875	1.5	QSPD-015-120	36.40	QSPD-015-120X	38.30
	.0200	.060	.002	I	.590	.1875	1.5	QSPD-020-120	36.40	QSPD-020-120X	38.30
	.0250	.075	.002	I	.590	.1875	1.5	QSPD-025-120	32.35	QSPD-025-120X	34.25
	.0300	.090	.003	I	.590	.1875	1.5	QSPD-030-120	32.35	QSPD-030-120X	34.25
	.0350	.105	.003	I	.590	.1875	1.5	QSPD-035-120	32.35	QSPD-035-120X	34.25
	.0400	.120	.004	I	.590	.1875	1.5	QSPD-040-120	28.15	QSPD-040-120X	30.05
	.0450	.135	.004	I	.590	.1875	1.5	QSPD-045-120	28.15	QSPD-045-120X	30.05
	.0500	.150	.005	I	.590	.1875	1.5	QSPD-050-120	28.15	QSPD-050-120X	30.05
	.0600	.180	.006	I	.590	.1875	1.5	QSPD-060-120	28.15	QSPD-060-120X	30.05
	.0900	.270	.006	I	.590	.1875	1.5	QSPD-090-120	28.15	QSPD-090-120X	30.05
	.1181	.354	.008	I	.590	.1875	1.5	QSPD-118-120	28.15	QSPD-118-120X	30.05
	.1250	.375	.010	I	.590	.1875	1.5	QSPD-125-120	28.15	QSPD-125-120X	30.05
	.1875	.625	.005	II	1.090	.1875	2.0	QSPD-187-120	28.15	QSPD-187-120X	30.05
	.2500	.750	.005	II	1.353	.2500	2.5	QSPD-250-120	33.15	QSPD-250-120X	37.05
.3750	1.000	.005	II	1.353	.3750	2.5	QSPD-375-120	44.65	QSPD-375-120X	50.45	

See pg 50-62 for quick change holder options

Continued on next page

# Quick Change – Holemaking Tools

QSPD

## Spotting Drills (cont.)

Continued from previous page

Included Angle	Drill Diameter	Flute Length	Web Thickness	Type	Length From Holder	Shank Diameter	Overall Length	Uncoated		AITIN Coated	
								Tool #	Price	Tool #	Price
A	D1 $\begin{matrix} +.0000" \\ -.0005" \end{matrix}$	L2 $\begin{matrix} +.010" \\ -.001" \end{matrix}$	$\begin{matrix} +.001" \\ -.000" \end{matrix}$		L4	D2 (h6)	L1				
140°	.0150	.045	.002	I	.590	.1875	1.5	QSPD-015-140	36.40	QSPD-015-140X	38.30
	.0200	.060	.002	I	.590	.1875	1.5	QSPD-020-140	36.40	QSPD-020-140X	38.30
	.0250	.075	.002	I	.590	.1875	1.5	QSPD-025-140	32.35	QSPD-025-140X	34.25
	.0300	.090	.003	I	.590	.1875	1.5	QSPD-030-140	32.35	QSPD-030-140X	34.25
	.0350	.105	.003	I	.590	.1875	1.5	QSPD-035-140	32.35	QSPD-035-140X	34.25
	.0400	.120	.004	I	.590	.1875	1.5	QSPD-040-140	28.15		
	.0450	.135	.004	I	.590	.1875	1.5	QSPD-045-140	28.15	QSPD-045-140X	30.05
	.0500	.150	.005	I	.590	.1875	1.5	QSPD-050-140	28.15	QSPD-050-140X	30.05
	.0600	.180	.006	I	.590	.1875	1.5	QSPD-060-140	28.15	QSPD-060-140X	30.05
	.0900	.270	.006	I	.590	.1875	1.5	QSPD-090-140	28.15	QSPD-090-140X	30.05
	.1181	.354	.008	I	.590	.1875	1.5	QSPD-118-140	28.15	QSPD-118-140X	30.05
	.1250	.375	.010	I	.590	.1875	1.5	QSPD-125-140	28.15	QSPD-125-140X	30.05
	.1875	.625	.005	II	1.090	.1875	2.0	QSPD-187-140	28.15	QSPD-187-140X	30.05
	.2500	.750	.005	II	1.353	.2500	2.5	QSPD-250-140	33.15	QSPD-250-140X	37.05
.3750	1.000	.005	II	1.353	.3750	2.5	QSPD-375-140	44.65	QSPD-375-140X	50.45	

See pg 50-62 for quick change holder options

Quick Change – Holemaking Tools

## QDC

## Quick Change – Holmaking Tools

### Combined Drill & Countersink Tools

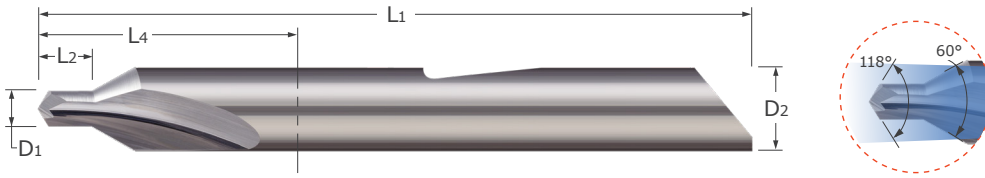

- Designed for pre-drilling 60° live center holes
- Can be utilized for countersinking and spot drilling
- Coolant fed enabled shank design
- Proprietary Micro-Quik™ quick change system maximizes productivity through reliable accuracy and locational repeatability
- AlTiN coated option provides added lubricity and increased wear resistance in difficult to machine materials
- Solid carbide ■ CNC ground in the USA

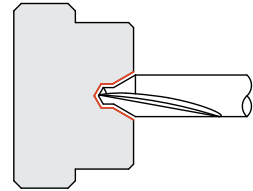

Drill Diameter	Drill Length	Length From Holder	Shank Diameter	Overall Length	Uncoated		AlTiN Coated	
					Tool #	Price	Tool #	Price
D1 $\begin{matrix} +.003'' \\ -.000'' \end{matrix}$	L2 $\begin{matrix} +.015'' \\ -.000'' \end{matrix}$	L4	D2 (h6)	L1	Tool #	Price	Tool #	Price
.025	.025	1.090	.1875	2.0	QDC-00	22.25	QDC-00X	24.15
.031	.031	1.090	.1875	2.0	QDC-01	22.25	QDC-01X	24.15
.047	.047	1.090	.1875	2.0	QDC-1	22.25	QDC-1X	24.15
D1 $\begin{matrix} +.003'' \\ -.000'' \end{matrix}$	L2 $\begin{matrix} +.030'' \\ -.000'' \end{matrix}$	L4	D2 (h6)	L1	Tool #	Price	Tool #	Price
.078	.078	1.090	.1875	2.0	QDC-2	22.25	QDC-2X	24.15
.109	.109	1.353	.2500	2.5	QDC-3	38.90	QDC-3X	42.80
.125	.125	1.353	.3125	2.5	QDC-4	51.95	QDC-4X	57.75
.188	.188	1.540	.5000	3.0	QDC-5	78.30	QDC-5X	85.45
.219	.219	1.540	.5000	3.0	QDC-6	78.30	QDC-6X	85.45

See pg 50-62 for quick change holder options

# Quick Change – Holemaking Tools

QSD

## Spade Drills

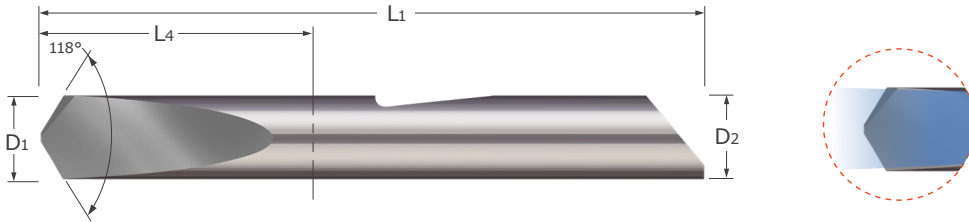

- Designed for drilling in hardened materials
- Excellent option when requiring holes free of retract marks in non-ferrous materials
- Coolant fed enabled shank design
- Point geometry designed for self-centering
- 118° tip angle
- Coolant fed enabled shank design
- Proprietary Micro-Quik™ quick change system maximizes productivity through reliable accuracy and locational repeatability
- AlTiN coated option provides added lubricity and increased wear resistance in difficult to machine materials
- Solid carbide ■ CNC ground in the USA

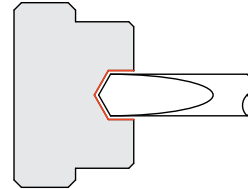

Quick Change – Holemaking Tools

Drill Diameter	Web Thickness	Length From Holder	Shank Diameter	Overall Length	Uncoated		AlTiN Coated	
					Tool #	Price	Tool #	Price
D1 $+0.0000"$ $-0.0005"$	$+0.001"$ $-0.001"$	L4	D2 (h6)	L1				
.0312	.010	.340	.1875	1.25	QSD-031	16.40	QSD-031X	18.30
.0625	.012	.590	.1875	1.50	QSD-062	17.05	QSD-062X	18.95
.0938	.016	.590	.1875	1.50	QSD-093	17.50	QSD-093X	19.40
.1250	.020	.590	.1875	1.50	QSD-125	19.25	QSD-125X	21.15
.1562	.025	1.090	.1875	2.00	QSD-156	21.00	QSD-156X	22.90
.1875	.028	1.090	.1875	2.00	QSD-187	24.45	QSD-187X	26.35
.2500	.035	.853	.2500	2.00	QSD-250	32.90	QSD-250X	34.80
.3125	.040	1.353	.3125	2.50	QSD-312	45.50	QSD-312X	47.40
.3750	.046	1.353	.3750	2.50	QSD-375	54.85	QSD-375X	56.75

See pg 50-62 for quick change holder options



QCS

Quick Change – Holmaking Tools  
Countersink & Chamfer Tools

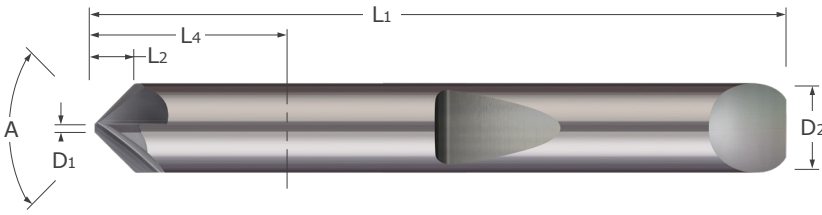

- Designed for countersinking and chamfering
- Available in 60°, 82°, 90°, 100°, and 120° included angles
- Tip Diameter (D<sub>1</sub>) is non-cutting
- Multi-tooth for greater metal removal rates
- Coolant fed enabled shank design
- Proprietary Micro-Quik™ quick change system maximizes productivity through reliable accuracy and locational repeatability
- AlTiN coated option provides added lubricity and increased wear resistance in difficult to machine materials
- Solid carbide ■ CNC ground in the USA

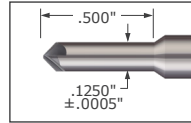

\*QCS-125 tools feature a necked down shank

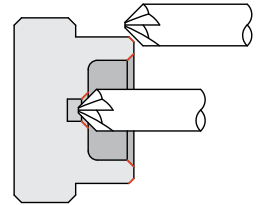

Included Angle	Tip Diameter	Length of Cut	Flutes	Length From Holder	Shank Diameter	Overall Length	Uncoated		AlTiN Coated	
							Tool #	Price	Tool #	Price
A <sup>+1°</sup> <sub>-1°</sub>	D <sub>1</sub> <sup>+0.001</sup> <sub>-0.003</sub>	L <sub>2</sub>		L <sub>4</sub>	D <sub>2</sub> (h6)	L <sub>1</sub>				
60°	.030	.082	3	.590	.1875	1.5	QCS-125-060*	32.10	QCS-125-060X*	34.00
	.040	.128	4	1.090	.1875	2.0	QCS-187-060	32.10	QCS-187-060X	34.00
	.050	.173	6	1.353	.2500	2.5	QCS-250-060	36.65	QCS-250-060X	40.55
	.060	.219	6	1.353	.3125	2.5	QCS-312-060	49.20	QCS-312-060X	55.00
	.070	.264	6	1.353	.3750	2.5	QCS-375-060	60.95	QCS-375-060X	66.75
	.080	.364	6	1.540	.5000	3.0	QCS-500-060	84.90	QCS-500-060X	92.05
82°	.030	.055	3	.590	.1875	1.5	QCS-125-082*	32.10	QCS-125-082X*	34.00
	.040	.085	4	1.090	.1875	2.0	QCS-187-082	32.10	QCS-187-082X	34.00
	.050	.115	6	1.353	.2500	2.5	QCS-250-082	36.65	QCS-250-082X	40.55
	.060	.145	6	1.353	.3125	2.5	QCS-312-082	49.20	QCS-312-082X	55.00
	.070	.175	6	1.353	.3750	2.5	QCS-375-082	60.95	QCS-375-082X	66.75
	.080	.242	6	1.540	.5000	3.0	QCS-500-082	84.90	QCS-500-082X	92.05
90°	.030	.047	3	.590	.1875	1.5	QCS-125-090*	32.10	QCS-125-090X*	34.00
	.040	.074	4	1.090	.1875	2.0	QCS-187-090	32.10	QCS-187-090X	34.00
	.050	.100	6	1.353	.2500	2.5	QCS-250-090	36.65	QCS-250-090X	40.55
	.060	.126	6	1.353	.3125	2.5	QCS-312-090	49.20	QCS-312-090X	55.00
	.070	.152	6	1.353	.3750	2.5	QCS-375-090	60.95	QCS-375-090X	66.75
	.080	.210	6	1.540	.5000	3.0	QCS-500-090	84.90	QCS-500-090X	92.05
100°	.030	.040	3	.590	.1875	1.5	QCS-125-100*	32.10	QCS-125-100X*	34.00
	.040	.062	4	1.090	.1875	2.0	QCS-187-100	32.10	QCS-187-100X	34.00
	.050	.084	6	1.353	.2500	2.5	QCS-250-100	36.65	QCS-250-100X	40.55
	.060	.106	6	1.353	.3125	2.5	QCS-312-100	49.20	QCS-312-100X	55.00
	.070	.128	6	1.353	.3750	2.5	QCS-375-100	60.95	QCS-375-100X	66.75
	.080	.176	6	1.540	.5000	3.0	QCS-500-100	84.90	QCS-500-100X	92.05
120°	.030	.027	3	.590	.1875	1.5	QCS-125-120*	32.10	QCS-125-120X*	34.00
	.040	.043	4	1.090	.1875	2.0	QCS-187-120	32.10	QCS-187-120X	34.00
	.050	.058	6	1.353	.2500	2.5	QCS-250-120	36.65	QCS-250-120X	40.55
	.060	.073	6	1.353	.3125	2.5	QCS-312-120	49.20	QCS-312-120X	55.00
	.070	.088	6	1.353	.3750	2.5	QCS-375-120	60.95	QCS-375-120X	66.75
	.080	.121	6	1.540	.5000	3.0	QCS-500-120	84.90	QCS-500-120X	92.05

\*QCS-125 tools feature a necked down shank

See pg 50-62 for quick change holder options

# Quick Change – Holders & Parts

QTS / QTSP

## Tool Holders – Straight Holder – Standard Length

Quick Change – Holemaking Tools

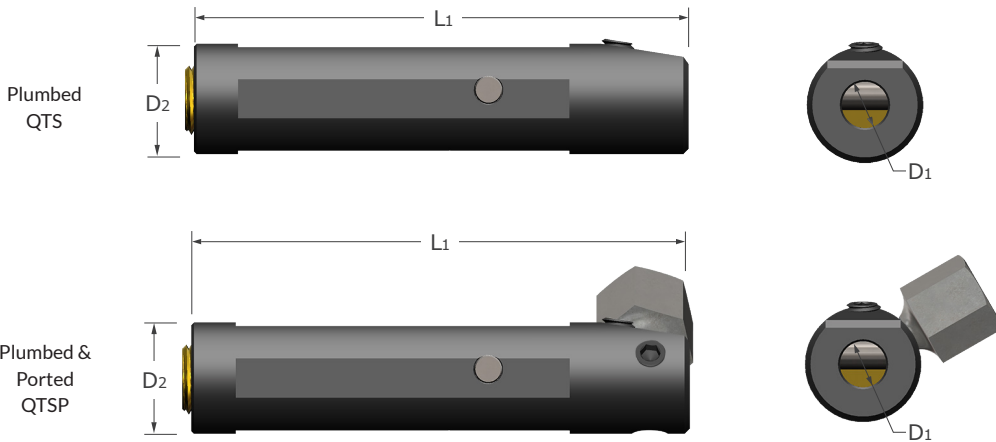

- Headless tool holder engineered for maximum versatility in any Swiss, standard lathe, or multi-function lathe
- Standard plumbed and 3 ported options for more enhanced coolant accessibility
- Proprietary Micro-Quik™ quick change system maximizes productivity through reliable accuracy and locational repeatability
- Headless design allows for installation through the back of the tooling block in machines where work envelope is limited
- Top screw orientation for easy access to set screw without interference of adjacent tools
- 4 alignment flats allow for multiple tool engagements and holder orientations
- Holder plumbed for NPT coolant connection
- Heat treated and black oxide coated for durability and corrosion resistance
- Precision manufactured in the USA

Internal Diameter	Shank Diameter	Coolant Access Type	Plumbed Thread	Overall Length	Locating Locking Screw	Tool Holder	
D1 +.0005" -.0000"	D2 -.0003" -.0008" -.008mm -.020mm			L1		Tool #	Price
.1875	12 mm	Plumbed	1/8-27	2.8	40215	QTS-187-472	120.00 NEW
.1875	.5000	Plumbed	1/8-27	2.8	40215	QTS-187-500	120.00 NEW
.1875	.6250	Plumbed	1/8-27	2.8	40215	QTS-187-625	130.00 NEW
.1875	16 mm	Plumbed	1/8-27	2.8	40215	QTS-187-630	130.00 NEW
.1875	.7500	Plumbed & Ported	1/8-27	2.8	40216	QTSP-187-750	175.00 NEW
.1875	20 mm	Plumbed & Ported	1/8-27	2.8	40216	QTSP-187-787	175.00 NEW
.1875	22 mm	Plumbed & Ported	1/8-27	2.8	40216	QTSP-187-866	175.00 NEW
.1875	25 mm	Plumbed & Ported	1/8-27	2.8	40208	QTSP-187-984	175.00 NEW
.1875	1.0000	Plumbed & Ported	1/8-27	2.8	40208	QTSP-187-1000	175.00 NEW

Continued on next page

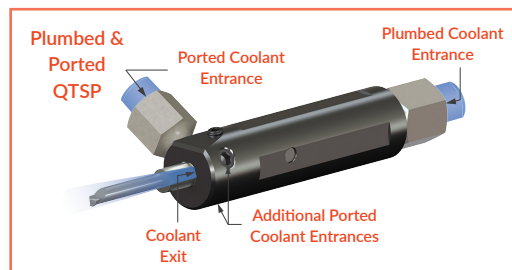
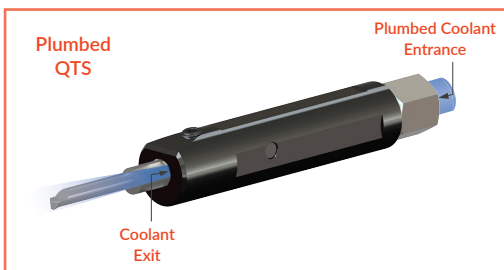

## QTS / QTSP

## Quick Change – Holders &amp; Parts

## Tool Holders – Straight Holder – Standard Length (cont.)

Continued from previous page

	Internal Diameter	Shank Diameter	Coolant Access Type	Plumbed Thread	Overall Length	Locating Locking Screw	Tool Holder	
	D <sub>1</sub> $\begin{matrix} +.0005" \\ -.0000" \end{matrix}$	D <sub>2</sub> $\begin{matrix} -.0003" \\ -.0008" \\ -.008mm \\ -.020mm \end{matrix}$			L <sub>1</sub>		Tool #	Price
NEW	.2500	12 mm	Plumbed	1/8-27	2.8	40215	QTS-250-472	120.00
NEW	.2500	.5000	Plumbed	1/8-27	2.8	40215	QTS-250-500	120.00
NEW	.2500	.6250	Plumbed	1/8-27	2.8	40215	QTS-250-625	130.00
NEW	.2500	16 mm	Plumbed	1/8-27	2.8	40215	QTS-250-630	130.00
NEW	.2500	.7500	Plumbed & Ported	1/8-27	2.8	40216	QTSP-250-750	175.00
NEW	.2500	20 mm	Plumbed & Ported	1/8-27	2.8	40216	QTSP-250-787	175.00
NEW	.2500	22 mm	Plumbed & Ported	1/8-27	2.8	40216	QTSP-250-866	175.00
NEW	.2500	25 mm	Plumbed & Ported	1/8-27	2.8	40216	QTSP-250-984	175.00
NEW	.2500	1.0000	Plumbed & Ported	1/8-27	2.8	40208	QTSP-250-1000	175.00
NEW	.3125	.6250	Plumbed	1/4-18	2.8	40215	QTS-312-625	130.00
NEW	.3125	16 mm	Plumbed	1/8-27	2.8	40215	QTS-312-630	130.00
NEW	.3125	.7500	Plumbed	1/4-18	2.8	40215	QTS-312-750	140.00
NEW	.3125	20 mm	Plumbed	1/4-18	2.8	40215	QTS-312-787	140.00
NEW	.3125	22 mm	Plumbed & Ported	1/4-18	2.8	40216	QTSP-312-866	175.00
NEW	.3125	25 mm	Plumbed & Ported	1/4-18	2.8	40216	QTSP-312-984	175.00
NEW	.3125	1.0000	Plumbed & Ported	1/4-18	2.8	40216	QTSP-312-1000	175.00
NEW	.3750	.6250	Plumbed	1/4-18	2.8	40215	QTS-375-625	130.00
NEW	.3750	.7500	Plumbed	1/4-18	2.8	40215	QTS-375-750	140.00
NEW	.3750	20 mm	Plumbed	1/4-18	2.8	40215	QTS-375-787	140.00
NEW	.3750	22 mm	Plumbed & Ported	1/4-18	2.8	40215	QTSP-375-866	175.00
NEW	.3750	25 mm	Plumbed & Ported	1/4-18	2.8	40216	QTSP-375-984	175.00
NEW	.3750	1.0000	Plumbed & Ported	1/4-18	2.8	40216	QTSP-375-1000	175.00
NEW	.5000	.7500	Plumbed	3/8-18	2.8	40215	QTS-500-750	140.00
NEW	.5000	1.0000	Plumbed & Ported	3/8-18	2.8	40216	QTSP-500-1000	160.00

# Quick Change – Holders & Parts

QTSL / QTSP

## Tool Holders – Straight Holder – Long Length



- Quick change, long length tool holder designed for applications requiring an extended reach
- Headless tool holder engineered for maximum versatility in any Swiss, standard lathe, or multi-function lathe
- Standard plumbed and 3 ported options for more enhanced coolant accessibility
- Proprietary Micro-Quik™ quick change system maximizes productivity through reliable accuracy and locational repeatability
- Headless design for installation through the back of the tooling block in machines where work envelope is limited
- Top screw orientation for easy access to set screw without interference of adjacent tools
- 4 alignment flats allow for multiple tool engagements and holder orientations
- Heat treated and black oxide coated for durability and corrosion resistance
- Precision manufactured in the USA

Quick Change – Holemaking Tools

Internal Diameter	Shank Diameter	Coolant Access Type	Plumbed Thread	Overall Length	Locating Locking Screw	Tool Holder		
D1 $+0.0005"$ $-0.0000"$	D2 $-0.0003"$ $-0.0008"$ $-0.008mm$ $-0.020mm$			L1		Tool #	Price	
.1875	.7500	Plumbed & Ported	1/8-27	5.8	40216	QTSP-187-750	215.00	NEW
.1875	20 mm	Plumbed & Ported	1/8-27	5.8	40216	QTSP-187-787	215.00	NEW
.1875	22 mm	Plumbed & Ported	1/8-27	5.8	40216	QTSP-187-866	215.00	NEW
.1875	25 mm	Plumbed & Ported	1/8-27	5.8	40208	QTSP-187-984	215.00	NEW
.1875	1.0000	Plumbed & Ported	1/8-27	5.8	40208	QTSP-187-1000	215.00	NEW
.2500	.7500	Plumbed & Ported	1/8-27	5.8	40216	QTSP-250-750	215.00	NEW
.2500	20 mm	Plumbed & Ported	1/8-27	5.8	40216	QTSP-250-787	215.00	NEW
.2500	22 mm	Plumbed & Ported	1/8-27	5.8	40216	QTSP-250-866	215.00	NEW
.2500	25 mm	Plumbed & Ported	1/8-27	5.8	40216	QTSP-250-984	215.00	NEW
.2500	1.0000	Plumbed & Ported	1/8-27	5.8	40208	QTSP-250-1000	215.00	NEW
.3125	22 mm	Plumbed & Ported	1/4-18	5.8	40216	QTSP-312-866	215.00	NEW
.3125	25 mm	Plumbed & Ported	1/4-18	5.8	40216	QTSP-312-984	215.00	NEW
.3125	1.0000	Plumbed & Ported	1/4-18	5.8	40216	QTSP-312-1000	215.00	NEW
.3750	22 mm	Plumbed	1/4-18	5.8	40215	QTSL-375-866*	180.00	NEW
.3750	25 mm	Plumbed & Ported	1/4-18	5.8	40216	QTSP-375-984	215.00	NEW
.3750	1.0000	Plumbed & Ported	1/4-18	5.8	40216	QTSP-375-1000	215.00	NEW

\*Item not ported

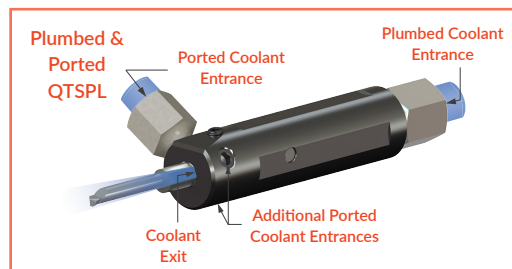
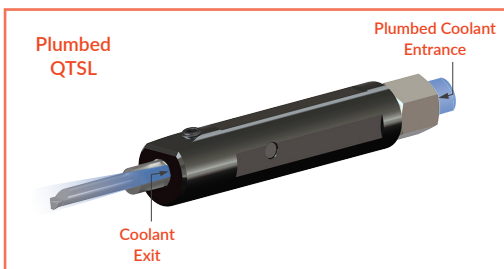

## QTH / QTHM

## Quick Change – Holders &amp; Parts

## Tool Holders – Headed Holder – Standard Length

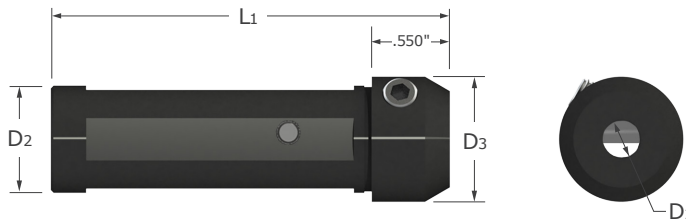

- Quick change tool holder plumbed for NPT coolant connection and designed for use in lathe applications
- Proprietary Micro-Quik™ quick change system maximizes productivity through reliable accuracy and locational repeatability
- Unique “3 point” locking and locating system ensures axial and radial tool repeatability, tip-to-tip consistency, and part-to-part accuracy
- 4 alignment flats allow for multiple tool engagements and holder orientations
- Heat treated and black oxide coated for durability and corrosion resistance
- Precision manufactured in the USA

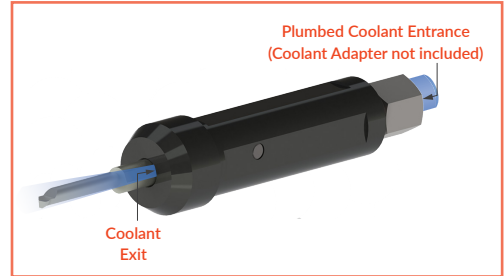

Internal Diameter	Collar Diameter	Plumbed Thread	Shank Diameter	Overall Length	Tool Holder	
					Tool #	Price
D1 $+0.0005"$ $-0.0000"$	D3 $+0.003"$ $-0.003"$		D2 $-0.0003"$ $-0.0008"$ $-0.008mm$ $-0.020mm$	L1		
.1875	.750	1/8-27 NPT	12 mm	2.8	QTHM-312	110.00
.1875	.750	1/8-27 NPT	.5000	2.8	QTH-85	110.00
.1875	.750	1/8-27 NPT	.6250	2.8	QTH-105	120.00
.1875	.750	1/8-27 NPT	16 mm	2.8	QTHM-316	120.00
.1875	.875	1/4-18 NPT	.7500	2.8	QTH-205	130.00
.1875	.875	1/4-18 NPT	20 mm	2.8	QTHM-320	130.00
.1875	1.062	1/4-18 NPT	22 mm	2.8	QTHM-322	130.00
.1875	1.250	1/4-18 NPT	25 mm	2.8	QTHM-325	130.00
.1875	1.062	1/4-18 NPT	1.0000	2.8	QTH-405	130.00
.1875	-	1/4-18 NPT	1.2500	2.8	QTH-605	130.00
.1875	-	1/4-18 NPT	32 mm	2.8	QTHM-332	130.00
.2500	.750	1/8-27 NPT	12 mm	2.8	QTHM-412	110.00
.2500	.750	1/8-27 NPT	.5000	2.8	QTH-86	110.00
.2500	.750	1/8-27 NPT	.6250	2.8	QTH-106	120.00
.2500	.750	1/8-27 NPT	16 mm	2.8	QTHM-416	120.00
.2500	.875	1/4-18 NPT	.7500	2.8	QTH-206	130.00
.2500	.875	1/4-18 NPT	20 mm	2.8	QTHM-420	130.00
.2500	1.062	1/4-18 NPT	22 mm	2.8	QTHM-422	130.00
.2500	1.250	1/4-18 NPT	25 mm	2.8	QTHM-425	130.00
.2500	1.062	1/4-18 NPT	1.0000	2.8	QTH-406	130.00
.2500	-	1/4-18 NPT	1.2500	2.8	QTH-606	130.00
.2500	-	1/4-18 NPT	32 mm	2.8	QTHM-432	130.00

Continued on next page

# Quick Change – Holders & Parts

QTH / QTHM

## Tool Holders – Headed Holder – Standard Length (cont.)

Continued from previous page

Internal Diameter	Collar Diameter	Plumbed Thread	Shank Diameter	Overall Length	Tool Holder	
					Tool #	Price
D1 $+0.005"$ $-0.000"$	D3 $+0.003"$ $-0.003"$		D2 $-0.0003"$ $-0.0008"$ $-0.008mm$ $-0.020mm$	L1		
.3125	.875	1/8-27 NPT	.6250	2.8	QTH-107	120.00
.3125	.875	1/8-27 NPT	16 mm	2.8	QTHM-516	120.00
.3125	.875	1/4-18 NPT	.7500	2.8	QTH-207	130.00
.3125	.875	1/4-18 NPT	20 mm	2.8	QTHM-520	130.00
.3125	1.062	1/4-18 NPT	22 mm	2.8	QTHM-522	130.00
.3125	1.250	1/4-18 NPT	25 mm	2.8	QTHM-525	130.00
.3125	1.062	1/4-18 NPT	1.0000	2.8	QTH-407	130.00
.3125	-	1/4-18 NPT	1.2500	2.8	QTH-607	130.00
.3125	-	1/4-18 NPT	32 mm	2.8	QTHM-532	130.00
.3750	1.000	1/8-27 NPT	.6250	2.8	QTH-108	120.00
.3750	1.000	1/8-27 NPT	16 mm	2.8	QTHM-616	120.00
.3750	1.000	1/4-18 NPT	.7500	2.8	QTH-208	130.00
.3750	1.000	1/4-18 NPT	20 mm	2.8	QTHM-620	130.00
.3750	1.062	1/4-18 NPT	22 mm	2.8	QTHM-622	130.00
.3750	1.250	1/4-18 NPT	25 mm	2.8	QTHM-625	130.00
.3750	1.062	1/4-18 NPT	1.0000	2.8	QTH-408	130.00
.3750	-	1/4-18 NPT	1.2500	2.8	QTH-608	130.00
.3750	-	1/4-18 NPT	32 mm	2.8	QTHM-632	130.00
.5000	1.062	1/4-18 NPT	.7500	2.8	QTH-210	130.00
.5000	1.062	1/4-18 NPT	20 mm	2.8	QTHM-820	130.00
.5000	1.062	1/4-18 NPT	22 mm	2.8	QTHM-822	130.00
.5000	1.250	1/4-18 NPT	25 mm	2.8	QTHM-825	130.00
.5000	1.062	1/4-18 NPT	1.0000	2.8	QTH-410	130.00
.5000	-	1/4-18 NPT	1.2500	2.8	QTH-610	130.00
.5000	-	1/4-18 NPT	32 mm	2.8	QTHM-832	130.00

Quick Change – Holders & Parts

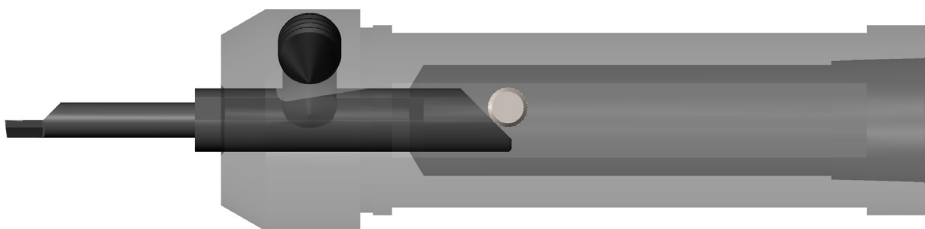
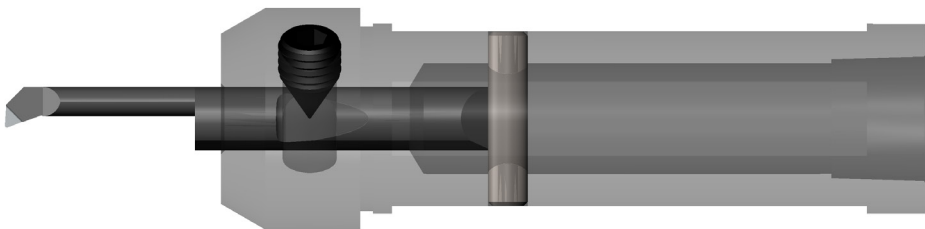

## QTHL / QTHML

## Quick Change – Holders & Parts

### Tool Holders – Headed Holder – Long Length



- Quick change, long length tool holder designed for applications requiring an extended reach
- Proprietary Micro-Quik™ quick change system maximizes productivity through reliable accuracy and locational repeatability
- Unique "3 point" locking and locating system ensures axial and radial tool repeatability, tip-to-tip consistency, and part-to-part accuracy
- 4 alignment flats allow for multiple tool engagements and holder orientation flexibility
- Holder plumbed for NPT coolant connection
- Heat treated and black oxide coated for durability and corrosion resistance
- Precision manufactured in the USA

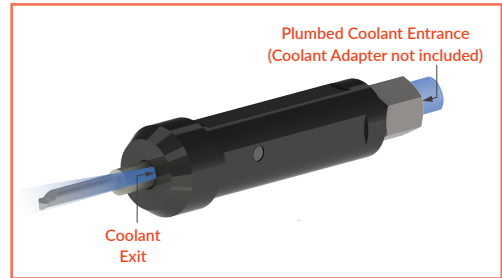

Internal Diameter	Collar Diameter	Plumbed Thread	Shank Diameter	Overall Length	Tool Holder	
					Tool #	Price
$D_1 \begin{smallmatrix} +.0005'' \\ -.0000'' \end{smallmatrix}$	$D_3 \begin{smallmatrix} +.003'' \\ -.003'' \end{smallmatrix}$		$D_2 \begin{smallmatrix} -.0003'' \\ -.0008'' \\ -.008\text{mm} \\ -.020\text{mm} \end{smallmatrix}$	L1		
.1875	.750	1/8-27 NPT	12 mm	5.8	QTHM-312L	150.00
.1875	.750	1/8-27 NPT	.5000	5.8	QTH-85L	150.00
.1875	.750	1/8-27 NPT	.6250	5.8	QTH-105L	160.00
.1875	.750	1/8-27 NPT	16 mm	5.8	QTHM-316L	160.00
.1875	.875	1/4-18 NPT	.7500	5.8	QTH-205L	170.00
.1875	1.062	1/4-18 NPT	20 mm	5.8	QTHM-320L	170.00
.1875	1.062	1/4-18 NPT	22 mm	5.8	QTHM-322L	170.00
.1875	1.062	1/4-18 NPT	1.0000	5.8	QTH-405L	170.00
.1875	1.250	1/4-18 NPT	25 mm	5.8	QTHM-325L	170.00
.1875	-	1/4-18 NPT	1.2500	5.8	QTH-605L	170.00
.1875	-	1/4-18 NPT	32 mm	5.8	QTHM-332L	170.00
.2500	.750	1/8-27 NPT	12 mm	5.8	QTHM-412L	150.00
.2500	.750	1/8-27 NPT	.5000	5.8	QTH-86L	150.00
.2500	.750	1/8-27 NPT	.6250	5.8	QTH-106L	160.00
.2500	.750	1/8-27 NPT	16 mm	5.8	QTHM-416L	160.00
.2500	.875	1/4-18 NPT	.7500	5.8	QTH-206L	170.00
.2500	1.062	1/4-18 NPT	20 mm	5.8	QTHM-420L	170.00
.2500	1.062	1/4-18 NPT	22 mm	5.8	QTHM-422L	170.00
.2500	1.062	1/4-18 NPT	1.0000	5.8	QTH-406L	170.00
.2500	1.250	1/4-18 NPT	25 mm	5.8	QTHM-425L	170.00
.2500	-	1/4-18 NPT	1.2500	5.8	QTH-606L	170.00
.2500	-	1/4-18 NPT	32 mm	5.8	QTHM-432L	170.00

Continued on next page

# Quick Change – Holders & Parts

QTHL / QTHML

## Tool Holders – Headed Holder – Long Length (cont.)

Continued from previous page

Internal Diameter	Collar Diameter	Plumbed Thread	Shank Diameter	Overall Length	Tool Holder	
					Tool #	Price
D1 $^{+.0005"}_{-.0000"}$	D3 $^{+.003"}_{-.003"}$		D2 $^{-.0003"}_{-.0008"}_{-.008\text{mm}}_{-.020\text{mm}}$	L1		
.3125	.875	1/8-27 NPT	.6250	5.8	QTH-107L	160.00
.3125	.875	1/8-27 NPT	16 mm	5.8	QTHM-516L	160.00
.3125	.875	1/8-27 NPT	.7500	5.8	QTH-207L	170.00
.3125	1.062	1/4-18 NPT	20 mm	5.8	QTHM-520L	170.00
.3125	1.062	1/4-18 NPT	22 mm	5.8	QTHM-522L	170.00
.3125	1.062	1/4-18 NPT	1.0000	5.8	QTH-407L	170.00
.3125	1.250	1/4-18 NPT	25 mm	5.8	QTHM-525L	170.00
.3125	-	1/4-18 NPT	1.2500	5.8	QTH-607L	170.00
.3125	-	1/4-18 NPT	32 mm	5.8	QTHM-532L	170.00
.3750	1.000	1/8-27 NPT	.6250	5.8	QTH-108L	160.00
.3750	1.000	1/8-27 NPT	16 mm	5.8	QTHM-616L	160.00
.3750	1.000	1/4-18 NPT	.7500	5.8	QTH-208L	170.00
.3750	1.062	1/4-18 NPT	20 mm	5.8	QTHM-620L	170.00
.3750	1.062	1/4-18 NPT	22 mm	5.8	QTHM-622L	170.00
.3750	1.062	1/4-18 NPT	1.0000	5.8	QTH-408L	170.00
.3750	1.250	1/4-18 NPT	25 mm	5.8	QTHM-625L	170.00
.3750	-	1/4-18 NPT	1.2500	5.8	QTH-608L	170.00
.3750	-	1/4-18 NPT	32 mm	5.8	QTHM-632L	170.00
.5000	1.062	1/4-18 NPT	.7500	5.8	QTH-210L	170.00
.5000	1.062	1/4-18 NPT	20 mm	5.8	QTHM-820L	170.00
.5000	1.062	1/4-18 NPT	22 mm	5.8	QTHM-822L	170.00
.5000	1.062	1/4-18 NPT	1.0000	5.8	QTH-410L	170.00
.5000	1.250	1/4-18 NPT	25 mm	5.8	QTHM-825L	170.00
.5000	-	1/4-18 NPT	1.2500	5.8	QTH-610L	170.00
.5000	-	1/4-18 NPT	32 mm	5.8	QTHM-832L	170.00

Quick Change – Holders & Parts



QDH / QDS / QDSM

Quick Change – Holders & Parts  
Tool Holder System – Double Ended Modular

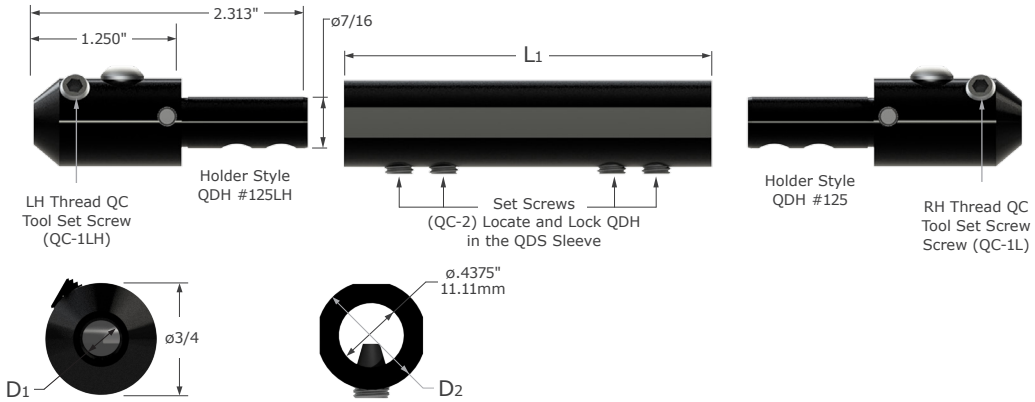

- Quick change tool holder designed for use in twin spindle and Y-axis tooling block locations
- Proprietary Micro-Quik™ quick change system maximizes productivity through reliable accuracy and locational repeatability
- Unique “3 point” locking and locating system ensures axial and radial tool repeatability, tip-to-tip consistency, and part-to-part accuracy
- 4 alignment flats allow for multiple tool engagements and holder orientation flexibility
- Assemble unit prior to installation to reduce setup time
- Left and right holder design orients set screws on the same side as operator for easy access
- Left hand head has left hand threaded set screw
- Ported adapter included for coolant delivery
- Heat treated and black oxide coated for durability and corrosion resistance
- Precision manufactured in the USA

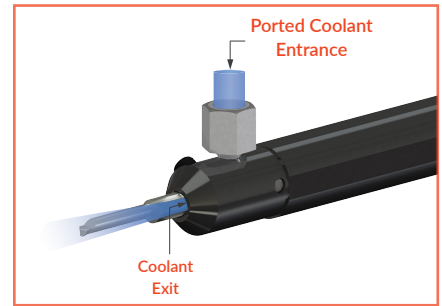

Sleeve Diameter	Length of Sleeve	Sleeve		Internal Diameter	Right Hand Tool Holder		Left Hand Tool Holder			
		Tool #	Price		Tool #	Price	Tool #	Price		
D2 $\begin{matrix} -.0003" \\ -.0008" \\ -.008mm \\ -.020mm \end{matrix}$	L1	Tool #	Price	D1 $\begin{matrix} +.0005" \\ -.0000" \end{matrix}$	QDS-750-2.5	125.00	QDH-3125	115.00	QDH-3125LH	115.00
					QDS-750-2.5	125.00	QDH-4125	115.00	QDH-4125LH	115.00
					QDS-750-2.5	125.00	QDH-5125	115.00	QDH-5125LH	115.00
.7500	2.5	QDS-750-2.5	125.00	.1875	QDS-750-3.1	130.00	QDH-3125	115.00	QDH-3125LH	115.00
					QDS-750-3.1	130.00	QDH-2500	115.00	QDH-4125LH	115.00
					QDS-750-3.1	130.00	QDH-3125	115.00	QDH-5125LH	115.00
.7500	3.1	QDS-750-3.1	130.00	.1875	QDSM-20-64	125.00	QDH-3125	115.00	QDH-3125LH	115.00
					QDSM-20-64	125.00	QDH-2500	115.00	QDH-4125LH	115.00
					QDSM-20-64	125.00	QDH-3125	115.00	QDH-5125LH	115.00
20 mm	64 mm	QDSM-20-64	125.00	.1875	QDSM-20-79	130.00	QDH-3125	115.00	QDH-3125LH	115.00
					QDSM-20-79	130.00	QDH-2500	115.00	QDH-4125LH	115.00
					QDSM-20-79	130.00	QDH-3125	115.00	QDH-5125LH	115.00
20 mm	79 mm	QDSM-20-79	130.00	.1875	QDSM-22-64	130.00	QDH-3125	115.00	QDH-3125LH	115.00
					QDSM-22-64	130.00	QDH-2500	115.00	QDH-4125LH	115.00
					QDSM-22-64	130.00	QDH-3125	115.00	QDH-5125LH	115.00
22 mm	64 mm	QDSM-22-64	130.00	.1875	QDSM-22-79	135.00	QDH-3125	115.00	QDH-3125LH	115.00
					QDSM-22-79	135.00	QDH-2500	115.00	QDH-4125LH	115.00
					QDSM-22-79	135.00	QDH-3125	115.00	QDH-5125LH	115.00
22 mm	79 mm	QDSM-22-79	135.00	.1875	QDSM-22-79	135.00	QDH-3125	115.00	QDH-3125LH	115.00
					QDSM-22-79	135.00	QDH-2500	115.00	QDH-4125LH	115.00
					QDSM-22-79	135.00	QDH-3125	115.00	QDH-5125LH	115.00

Continued on next page

# Quick Change – Holders & Parts

QDH / QDS / QDSM

## Tool Holder System – Double Ended Modular (cont.)

Continued from previous page

Sleeve Diameter	Length of Sleeve	Sleeve		Internal Diameter	Right Hand Tool Holder		Left Hand Tool Holder	
		Tool #	Price		Tool #	Price	Tool #	Price
D2 $\begin{matrix} -.0003'' \\ -.0008'' \\ -.008mm \\ -.020mm \end{matrix}$	L1			D1 $\begin{matrix} +.0005'' \\ -.0000'' \end{matrix}$				
25 mm	64 mm	QDSM-25-64	135.00	.1875	QDH-3125	115.00	QDH-3125LH	115.00
				.2500	QDH-4125	115.00	QDH-4125LH	115.00
				.3125	QDH-5125	115.00	QDH-5125LH	115.00
1.0000	2.500	QDS-1.00-2.5	135.00	.1875	QDH-3125	115.00	QDH-3125LH	115.00
				.2500	QDH-4125	115.00	QDH-4125LH	115.00
				.3125	QDH-5125	115.00	QDH-5125LH	115.00
1.0000	3.100	QDS-1.00-3.1	145.00	.1875	QDH-3125	115.00	QDH-3125LH	115.00
				.2500	QDH-4125	115.00	QDH-4125LH	115.00
					QDH-5125	115.00	QDH-5125LH	115.00

Quick Change – Holders & Parts

## QZST

## Quick Change – Holders & Parts

### Tool Holders – Star Swiss Machines – SR-10J

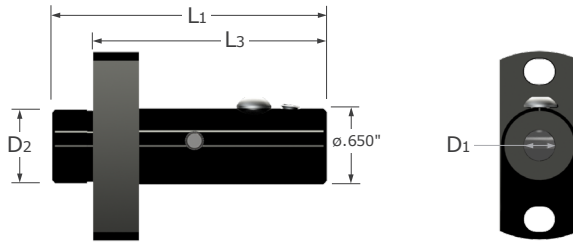

- Quick change tool holder designed for use in Star Swiss machine model SR-10J
- Proprietary Micro-Quik™ quick change system maximizes productivity through reliable accuracy and locational repeatability
- Designed for use with .1875", .2500", and .3125" diameter quick change tools
- Qualify with quick change centerline indicating tool (QI)
- Unique "3 point" locking and locating system ensures axial and radial tool repeatability, tip-to-tip consistency, and part-to-part accuracy
- Coolant delivered via external coolant port – adapter included
- Heat treated and black oxide coated for durability and corrosion resistance
- Precision manufactured in the USA

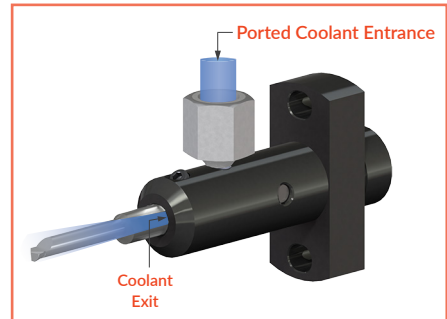

Internal Diameter	Overall Reach	Shank Diameter	Overall Length	Tool Holder	
				Tool #	Price
$D1 \begin{smallmatrix} +.0005" \\ -.0000" \end{smallmatrix}$	L3	D2	L1		
.1875	1.956	16 mm	2.350	QZST-316L-SR10J	249.00
.2500	1.956	16 mm	2.350	QZST-416L-SR10J	249.00
.3125	1.956	16 mm	2.350	QZST-516L-SR10J	249.00

See pg 64 for Centerline Indicating Tool

# Quick Change – Holders & Parts

QZST

## Tool Holders – Star Swiss Machines – SR-20

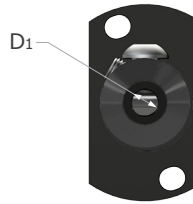
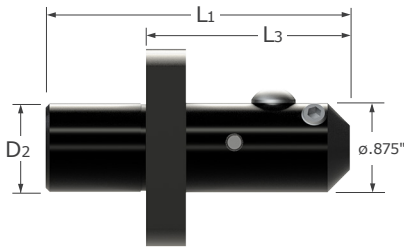

- Quick change tool holder designed for use in Star Swiss machine models SR-20, SB-16, SB-20R, SR-10J, SR-20J/JN, SR-20R, SR-20RIV, SR-32J/JN, SW-12R11, and SV-20R
- Proprietary Micro-Quik™ quick change system maximizes productivity through reliable accuracy and locational repeatability
- Designed for use with .1875", .2500", and .3125" diameter quick change tools
- Qualify with quick change centerline indicating tool (QI)
- Unique "3 point" locking and locating system ensures axial and radial tool repeatability, tip-to-tip consistency, and part-to-part accuracy
- Coolant delivered via external coolant port – adapter included
- Heat treated and black oxide coated for durability and corrosion resistance
- Precision manufactured in the USA

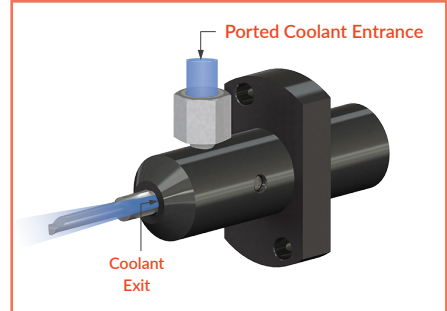

Quick Change – Holders & Parts

Internal Diameter	Overall Reach	Shank Diameter	Overall Length	Tool Holder	
				Tool #	Price
D1 <sup>+ .0005"</sup> <sub>- .0000"</sub>	L3	D2	L1		
.1875	1.400	22 mm	2.384	QZST-322-SR20	259.00
.1875	2.000	22 mm	2.984	QZST-322L-SR20	259.00
.2500	1.400	22 mm	2.384	QZST-422-SR20	259.00
.2500	2.000	22 mm	2.984	QZST-422L-SR20	259.00
.3125	1.400	22 mm	2.384	QZST-522-SR20	259.00
.3125	2.000	22 mm	2.984	QZST-522L-SR20	259.00

See pg 64 for Centerline Indicating Tool

QZST

Quick Change – Holders & Parts

Tool Holders – Star Swiss Machines – SR-20RIV

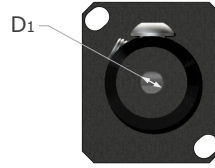
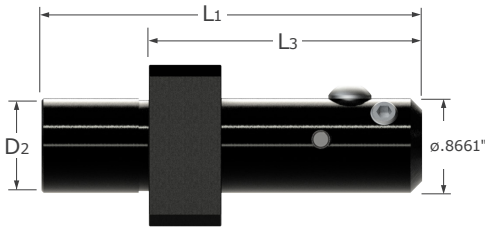

- Quick change tool holder designed for use in Star Swiss machine models SB-12/20R and SR-20RIV
- Proprietary Micro-Quik™ quick change system maximizes productivity through reliable accuracy and locational repeatability
- Designed for use with .1875", .2500", and .3125" diameter quick change tools
- Qualify with quick change centerline indicating tool (QI)
- Unique "3 point" locking and locating system ensures axial and radial tool repeatability, tip-to-tip consistency, and part-to-part accuracy
- Coolant delivered via external coolant port – adapter included
- Heat treated and black oxide coated for durability and corrosion resistance
- Precision manufactured in the USA

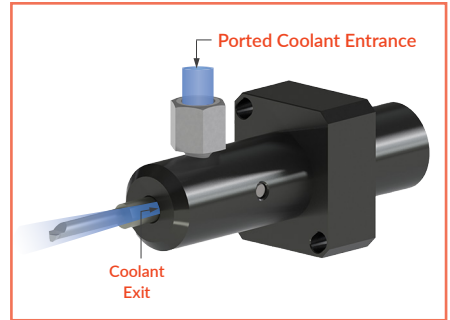

Quick Change – Holders & Parts

Internal Diameter	Overall Reach	Shank Diameter	Overall Length	Tool Holder	
				Tool #	Price
D1 <sup>+0.0005"</sup> <sub>-.0000"</sub>	L3	D2	L1		
.1875	2.510	22 mm	3.494	QZST-322L-SR20RIV	259.00
.2500	2.510	22 mm	3.494	QZST-422L-SR20RIV	259.00
.3125	2.510	22 mm	3.494	QZST-522L-SR20RIV	259.00

See pg 64 for Centerline Indicating Tool

# Quick Change – Holders & Parts

QZST

## Tool Holders – Star Swiss Machines – SW-20

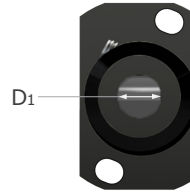
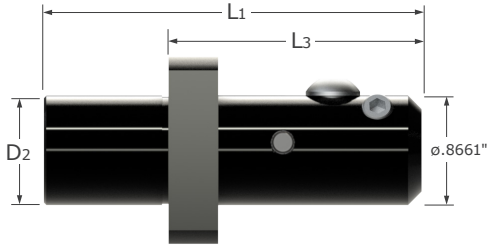

- Quick change tool holder designed for use in Star Swiss machine model SW20
- Proprietary Micro-Quik™ quick change system maximizes productivity through reliable accuracy and locational repeatability
- Designed for use with .1875", .2500", and .3125" diameter quick change tools
- Qualify with quick change centerline indicating tool (QI)
- Unique "3 point" locking and locating system ensures axial and radial tool repeatability, tip-to-tip consistency, and part-to-part accuracy
- Coolant delivered via external coolant port – adapter included
- Heat treated and black oxide coated for durability and corrosion resistance
- Precision manufactured in the USA

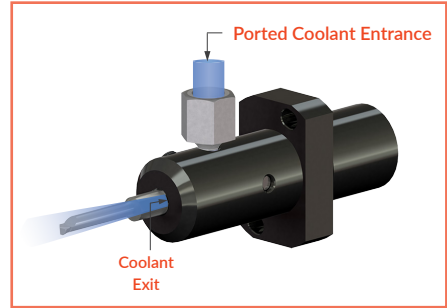

Quick Change – Holders & Parts

Internal Diameter	Overall Reach	Shank Diameter	Overall Length	Tool Holder	
				Tool #	Price
D1 <sup>+0.0005"</sup> <sub>-.0000"</sub>	L3	D2	L1		
.1875	2.000	22 mm	2.984	QZST-322L-SW20	259.00
.2500	2.000	22 mm	2.984	QZST-422L-SW20	259.00
.3125	2.000	22 mm	2.984	QZST-522L-SW20	259.00

See pg 64 for Centerline Indicating Tool

## QSG

## Quick Change – Holders & Parts

### Tool Holders – Grinding Holder – Square



- Square shank holder designed to enable repeatable grinding of custom tool profiles on quick change blanks
- Optimized for use with proprietary half round (QSP) and full round (QSR) quick change blanks
- Proprietary Micro-Quik™ quick change system maximizes productivity through reliable accuracy and locational repeatability
- Heat treated and black oxide coated for durability and corrosion resistance
- Precision manufactured in the USA

Internal Diameter	Collar Diameter	Square Shank	Overall Length	Tool Holder	
				Tool #	Price
D1 $\begin{matrix} +.0005" \\ -.0000" \end{matrix}$	D3 $\begin{matrix} +.005" \\ -.005" \end{matrix}$	A $\begin{matrix} +.0000" \\ -.0010" \end{matrix}$	L1		
.1875	.750	.5000	4.8	QSG-187-500	145.00
.1875	1.063	.7500	4.8	QSG-187-750	160.00
.2500	.750	.5000	4.8	QSG-250-500	145.00
.2500	1.063	.7500	4.8	QSG-250-750	160.00
.3125	.875	.5000	4.8	QSG-312-500	145.00
.3125	1.063	.7500	4.8	QSG-312-750	160.00
.3750	1.063	.7500	4.8	QSG-375-750	160.00
.5000	1.063	.7500	4.8	QSG-500-750	160.00

# Quick Change – Holders & Parts

QI

## Centerline Indicating Tool

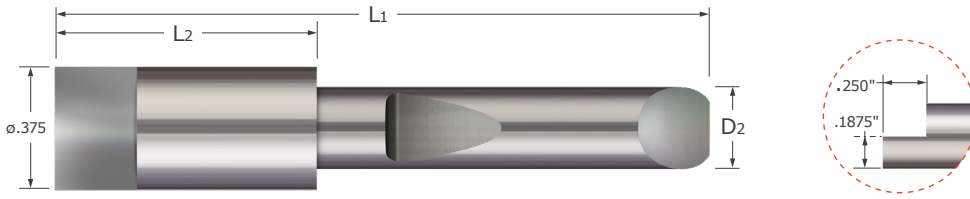

- Designed to accurately indicate centerline when using quick change holders
- Proprietary Micro-Quik™ quick change system maximizes productivity through reliable accuracy and locational repeatability
- Precision ground .375" flat provides a wide area for accurate and easy indicating during set up and post crash
- Precision manufactured in the USA

Quick Change – Holders & Parts

Shank Diameter	Body Length	Overall Length	Uncoated	
			Tool #	Price
D2 (h6)	L2 $\begin{matrix} +.000" \\ -.015" \end{matrix}$	L1		
.1875	1.000	2.0	QI-187	109.60
.2500	.800	2.0	QI-250	109.60
.3125	.800	2.0	QI-312	109.60



## QSP

## Quick Change – Holders &amp; Parts

## Blanks - Half Round

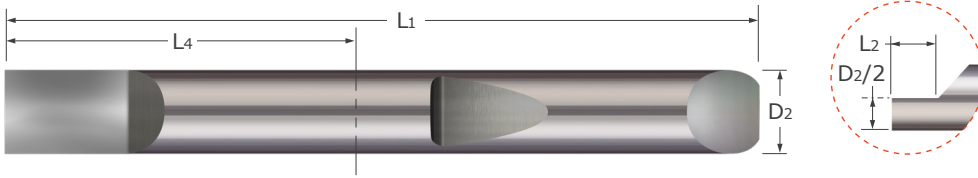

- Precision ground quick change blank designed for creating custom profiles requiring a split face
- Proprietary Micro-Quik™ quick change system maximizes productivity through reliable accuracy and locational repeatability
- Precision manufactured in the USA

Shank Diameter	Split Length*	Length from Holder	Overall Length	Tool Holder	
				Tool #	Price
D2 (h6)	L2 $\begin{matrix} +.005'' \\ -.000'' \end{matrix}$	L4	L1		
.1875	.375	.590	1.5	QSP-187-1.5	19.40
.1875	.375	1.090	2.0	QSP-187-2.0	20.70
.2500	.375	.853	2.0	QSP-250-2.0	22.00
.2500	.375	1.353	2.5	QSP-250-2.5	24.00
.2500	.375	1.853	3.0	QSP-250-3.0	25.90
.3125	.500	.853	2.0	QSP-312-2.0	29.50
.3125	.500	1.353	2.5	QSP-312-2.5	31.10
.3125	.500	1.853	3.0	QSP-312-3.0	34.90
.3750	.500	.853	2.0	QSP-375-2.0	37.40
.3750	.500	1.353	2.5	QSP-375-2.5	38.80
.3750	.500	1.853	3.0	QSP-375-3.0	41.60
.3750	.500	2.353	3.5	QSP-375-3.5	42.70
.3750	.500	2.853	4.0	QSP-375-4.0	47.40
.5000	.625	1.040	2.5	QSP-500-2.5	52.30
.5000	.625	1.540	3.0	QSP-500-3.0	55.00
.5000	.625	2.040	3.5	QSP-500-3.5	57.20
.5000	.625	2.540	4.0	QSP-500-4.0	60.20
.5000	.625	3.040	4.5	QSP-500-4.5	63.50

\*Centerline  $+ .001'' / -.000''$

# Quick Change – Holders & Parts

QSR

## Blanks – Full Round

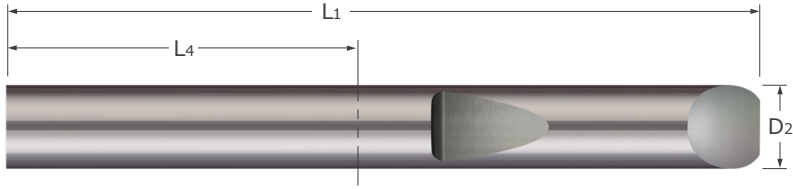

- Precision ground quick change blank designed for creating custom profiles
- Proprietary Micro-Quik™ quick change system maximizes productivity through reliable accuracy and locational repeatability
- Precision manufactured in the USA

Quick Change – Holders & Parts

Shank Diameter	Length from Holder	Overall Length	Tool Holder	
			Tool #	Price
D <sub>2</sub> (h6)	L <sub>4</sub>	L <sub>1</sub>		
.1875	.590	1.5	QSR-187-1.5	19.40
.1875	1.090	2.0	QSR-187-2.0	20.70
.2500	.853	2.0	QSR-250-2.0	22.00
.2500	1.353	2.5	QSR-250-2.5	24.00
.2500	1.853	3.0	QSR-250-3.0	25.90
.3125	.853	2.0	QSR-312-2.0	29.50
.3125	1.353	2.5	QSR-312-2.5	31.10
.3125	1.853	3.0	QSR-312-3.0	34.90
.3750	.853	2.0	QSR-375-2.0	37.40
.3750	1.353	2.5	QSR-375-2.5	38.80
.3750	1.853	3.0	QSR-375-3.0	41.60
.3750	2.353	3.5	QSR-375-3.5	42.70
.3750	2.853	4.0	QSR-375-4.0	47.40
.5000	1.040	2.5	QSR-500-2.5	52.30
.5000	1.540	3.0	QSR-500-3.0	55.00
.5000	2.040	3.5	QSR-500-3.5	57.20
.5000	2.540	4.0	QSR-500-4.0	60.20
.5000	3.040	4.5	QSR-500-4.5	63.50

QC

## Quick Change – Holders & Parts

### Tool Holder System – Replacement Parts

- Hardware and support tools for Micro 100 quick change tooling
- Sold individually or as packages of 10

	Accessory Type	Compatibility	Single		Package of 10		
			Tool #	Price	Tool #	Price	
		Locating / Locking Screw (Right Hand Threads)	Fits: QTH, QTHM, QZST, QSG, QDH Requires: QHT-1 Hex Key	QC-1	3.50	QC-10	25.00
		Locating / Locking Screw (Left Hand Threads)	Fits: QDH-3125LH, QDH-4125LH, QDH-5125LH Requires: QHT-1 Hex Key	QC-1LH	10.00	QC-10LH	90.00
NEW		Locating / Locking Screw	See QTS,QTSP,QTSL,QTSL tables for compatibility	40208	3.50	41208	25.00
NEW		Locating / Locking Screw	See QTS,QTSP,QTSL,QTSL tables for compatibility	40215	3.50	41215	25.00
NEW		Locating / Locking Screw	See QTS,QTSP,QTSL,QTSL tables for compatibility	40216	3.50	41216	25.00
		Locating / Locking Screw	Fits: QDS, QDSM Requires: QHT-1 Hex Key	QC-2	3.50	QC-20	25.00
		Button Head Screw (Plug) for High Pressure Coolant	Fits: QDH, QZST / Hex Key not stocked for this item	QC-5	1.00	QC-50	9.00
		Socket Set Screw	Fits: QZST-SR10J Requires: 3/32" Hex Key	QC-6	1.00	QC-60	9.00
NEW		Port Plug	Fits: QTSP, QTSL	40278	3.50	41278	25.00







Continued on next page

## Quick Change – Holders &amp; Parts

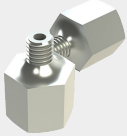
QC

## Tool Holder System – Replacement Parts (cont.)

Continued from previous page

	Accessory Type	Compatibility	Single		Package of 10	
			Tool #	Price	Tool #	Price
	High Pressure Coolant Fitting	Fits: QZST, QDH	QN-1	6.00	QN-10	50.00
	Hex Wrench	Fits: QC-3, QC-4 Locking Screws	QHK-1	1.00	QHK-10	9.00
	Hex Wrench	Fits: QC-6 Socket Set Screws	QHK-2	1.00	QHK-20	9.00
	Hex Wrench	Fits: 40208, 40215, 40216, Locating / Locking Screws	40213	1.00	41213	9.00 NEW
	Hex Wrench	Fits: 40278 Porting Plug	40249	1.00	41249	9.00 NEW
	T Style Handle Hex Wrench	Fits: QC-1, QC-1LH, QC-2 Locating / Locking Screws	QHT-1	5.25	QHT-10	45.00

# Standard – Boring Tools

## Right Hand – Sharp – Miniature

MBB / MBBM

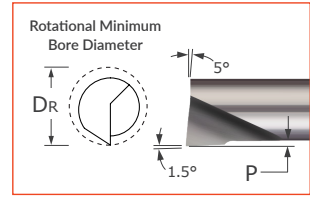
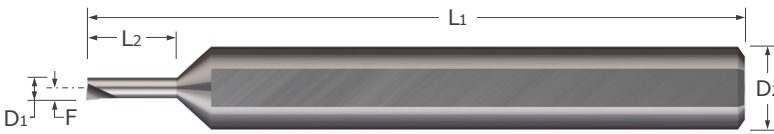

- Designed for facing and boring applications in bores .015" and larger
- Polished face for improved edge retention and chip evacuation while reducing galling
- Split geometry makes the tool as rigid as possible
- On center neck design allows for static (D<sub>1</sub>) and live/rotating (D<sub>R</sub>) applications
- Sharp corner profile ■ Lockdown flat automatically locates tool on center
- AlTiN coated option provides added lubricity and increased wear resistance in difficult to machine materials
- Solid carbide ■ CNC ground in the USA

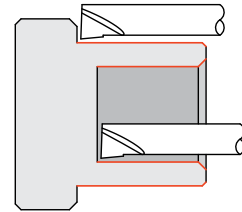

Minimum Bore Diameter		Rotational Minimum Bore Diameter	Maximum Bore Depth	Projection	Centerline Offset	Shank Dia.	OAL	Uncoated		AlTiN Coated	
D <sub>1</sub>	decimal equiv.	D <sub>R</sub>	L <sub>2</sub> +.010" -.000" +.25mm -.00mm	P	F	D <sub>2</sub> (h6)	L <sub>1</sub>	Tool #	Price	Tool #	Price
.0135	.0135	.015	.050	.0015	.0075	.1250	1.5	MBB-015050	36.55	MBB-015050X	39.05
	0.45 mm	.0177	2 mm	.05 mm	.25 mm	3 mm	38 mm	MBBM-005020	29.30	MBBM-005020X	31.80
.0180	.0180	.020	.075	.002	.0100	.1250	1.5	MBB-020075	36.55	MBB-020075X	39.05
	0.54 mm	.0213	2.5 mm	.06 mm	.30 mm	3 mm	38 mm	MBBM-006025	29.30	MBBM-006025X	31.80
.0225	.0225	.025	.100	.003	.0125	.1250	1.5	MBB-025100	32.20	MBB-025100X	34.70
	0.63 mm	.0248	3 mm	.07 mm	.35 mm	3 mm	38 mm	MBBM-007030	29.30		
	0.63 mm	.0248	4 mm	.07 mm	.35 mm	3 mm	38 mm	MBBM-007040	29.30		
.0270	.0270	.030	.100	.003	.0150	.1250	1.5	MBB-030100	32.20	MBB-030100X	34.70
	0.72 mm	.0283	3 mm	.08 mm	.40 mm	3 mm	38 mm	MBBM-008030	29.30	MBBM-008030X	31.80
	0.72 mm	.0283	4 mm	.08 mm	.40 mm	3 mm	38 mm	MBBM-008040	29.30	MBBM-008040X	31.80
.0315	.0315	.035	.100	.004	.0175	.1250	1.5	MBB-035100	32.20	MBB-035100X	34.70
.0315	.0315	.035	.150	.004	.0175	.1250	1.5	MBB-035150	32.20	MBB-035150X	34.70
	0.81 mm	.0317	3 mm	.09 mm	.45 mm	3 mm	38 mm	MBBM-009030	29.30		
	0.81 mm	.0317	4 mm	.09 mm	.45 mm	3 mm	38 mm	MBBM-009040	29.30		
	0.81 mm	.0317	5 mm	.09 mm	0.45 mm	3 mm	38 mm	MBBM-009050	29.30		
	0.91 mm	.0357	4 mm	.09 mm	0.50 mm	3 mm	38 mm	MBBM-010040	29.30		
	0.91 mm	.0357	5 mm	.09 mm	.50 mm	3 mm	38 mm	MBBM-010050	29.30		
.0360	.0360	.040	.100	.004	.0200	.1250	1.5	MBB-040100	32.20	MBB-040100X	34.70
.0360	.0360	.040	.150	.004	.0200	.1250	1.5	MBB-040150	32.20	MBB-040150X	34.70
.0360	.0360	.040	.200	.004	.0200	.1250	1.5	MBB-040200	32.20	MBB-040200X	34.70
.0405	.0405	.045	.100	.005	.0225	.1250	1.5	MBB-045100	32.20	MBB-045100X	34.70
.0405	.0405	.045	.150	.005	.0225	.1250	1.5	MBB-045150	32.20	MBB-045150X	34.70
.0405	.0405	.045	.200	.005	.0225	.1250	1.5	MBB-045200	32.20	MBB-045200X	34.70
.0440	.0440	.050	.150	.006	.0250	.1250	1.5	MBB-050150	32.20	MBB-050150X	34.70
.0525	.0525	.060	.150	.008	.0300	.1250	1.5	MBB-060150	32.20	MBB-060150X	34.70
.0525	.0525	.060	.200	.008	.0300	.1250	1.5	MBB-060200	32.20	MBB-060200X	34.70
.0625	.0625	.070	.200	.008	.0350	.1250	1.5	MBB-070200	32.20	MBB-070200X	34.70
.0625	.0625	.070	.300	.008	.0350	.1250	1.5	MBB-070300	32.20	MBB-070300X	34.70
.0700	.0700	.080	.150	.010	.0400	.1250	1.5	MBB-080150	32.20	MBB-080150X	34.70
.0700	.0700	.080	.200	.010	.0400	.1250	1.5	MBB-080200	32.20	MBB-080200X	34.70
.0800	.0800	.090	.300	.010	.0450	.1250	1.5	MBB-090300	32.20	MBB-090300X	34.70
.0875	.0875	.100	.200	.013	.0500	.1250	1.5	MBB-100200	32.20	MBB-100200X	34.70
.0875	.0875	.100	.300	.013	.0500	.1250	1.5	MBB-100300	32.20	MBB-100300X	34.70

See pg 270 for tool set options

# Standard – Boring Tools

BBS / BBM

Right Hand – Sharp

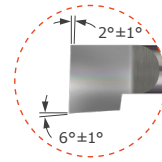
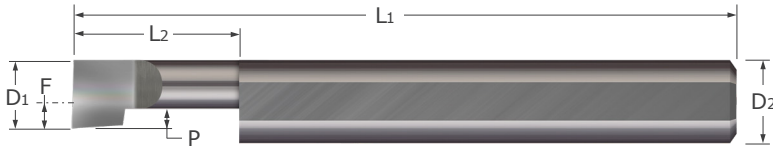

- Designed for facing and boring applications in bores .039" and larger
- Polished split face for improved edge retention and chip evacuation while reducing galling
- Split geometry makes the tool as rigid as possible
- Sharp corner profile
- Lockdown flat automatically locates tool on center
- Coating options provide added lubricity and increased wear resistance in difficult to machine materials
- Solid carbide ■ CNC ground in the USA

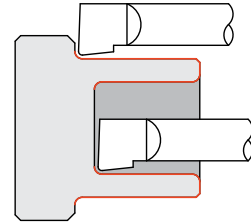

Standard – Boring Tools

Minimum Bore Diameter		Maximum Bore Depth	Projection	Centerline Offset	Shank Dia.	OAL	Uncoated		TIN Coated		AITIN Coated	
D1	decimal equiv.	L2 +.050" -.000" +1.24mm -.00mm	P	F	D2 (h6)	L1	Tool #	Price	Tool #	Price	Tool #	Price
1 mm	.0394	4 mm	.25 mm	-1 mm	4 mm	50 mm	BBM-040104	23.15	BBM-040104G	25.25	BBM-040104X	26.05
1 mm	.0394	6 mm	.25 mm	-1 mm	4 mm	50 mm	BBM-040106	23.15	BBM-040106G	25.25	BBM-040106X	26.05
1 mm	.0394	8 mm	.25 mm	-1 mm	4 mm	50 mm	BBM-040108	23.15	BBM-040108G	25.25	BBM-040108X	26.05
.050	.0500	.150	.012	-.013	.1250	1.5	BB-050150S	23.60	BB-050150SG	25.50	BB-050150SX	26.10
.050	.0500	.200	.012	-.013	.1250	1.5	BB-050200S	23.60	BB-050200SG	25.50	BB-050200SX	26.10
.050	.0500	.300	.012	-.013	.1250	1.5	BB-050300S	23.60	BB-050300SG	25.50	BB-050300SX	26.10
.050	.0500	.400	.012	-.013	.1250	1.5	BB-050400S	23.60	BB-050400SG	25.50	BB-050400SX	26.10
.060	.0600	.150	.015	-.003	.1250	1.5	BB-060150S	23.60	BB-060150SG	25.50	BB-060150SX	26.10
.060	.0600	.200	.015	-.003	.1250	1.5	BB-060200S	23.60	BB-060200SG	25.50	BB-060200SX	26.10
.060	.0600	.300	.015	-.003	.1250	1.5	BB-060300S	23.60	BB-060300SG	25.50	BB-060300SX	26.10
.060	.0600	.400	.015	-.003	.1250	1.5	BB-060400S	23.60	BB-060400SG	25.50	BB-060400SX	26.10
.060	.0600	.500	.015	-.003	.1250	1.5	BB-060500S	23.60	BB-060500SG	25.50	BB-060500SX	26.10
.070	.0700	.150	.015	.008	.1250	1.5	BB-070150S	23.60			BB-070150SX	26.10
.070	.0700	.200	.015	.008	.1250	1.5	BB-070200S	23.60			BB-070200SX	26.10
.070	.0700	.300	.015	.008	.1250	1.5	BB-070300S	23.60			BB-070300SX	26.10
2 mm	.0787	4 mm	.50 mm	0 mm	4 mm	50 mm	BBM-040204	23.15	BBM-040204G	25.25	BBM-040204X	26.05
2 mm	.0787	6 mm	.50 mm	0 mm	4 mm	50 mm	BBM-040206	23.15	BBM-040206G	25.25	BBM-040206X	26.05
2 mm	.0787	8 mm	.50 mm	0 mm	4 mm	50 mm	BBM-040208	23.15	BBM-040208G	25.25	BBM-040208X	26.05
2 mm	.0787	10 mm	.50 mm	0 mm	4 mm	50 mm	BBM-040210	23.15			BBM-040210X	26.05
2 mm	.0787	13 mm	.50 mm	0 mm	4 mm	50 mm	BBM-040213	23.15	BBM-040213G	25.25	BBM-040213X	26.05
.080	.0800	.150	.020	.018	.1250	1.5	BB-080150S	23.60	BB-080150SG	25.50	BB-080150SX	26.10
.080	.0800	.200	.020	.018	.1250	1.5	BB-080200S	23.60	BB-080200SG	25.50	BB-080200SX	26.10
.080	.0800	.300	.020	.018	.1250	1.5	BB-080300S	23.60	BB-080300SG	25.50	BB-080300SX	26.10
.080	.0800	.400	.020	.018	.1250	1.5	BB-080400S	23.60	BB-080400SG	25.50	BB-080400SX	26.10
.080	.0800	.500	.020	.018	.1250	1.5	BB-080500S	23.60	BB-080500SG	25.50	BB-080500SX	26.10
.080	.0800	.600	.020	.018	.1250	1.5	BB-080600S	23.60	BB-080600SG	25.50	BB-080600SX	26.10
.090	.0900	.300	.020	.028	.1250	1.5	BB-090300S	23.60			BB-090300SX	26.10

Continued on next page

## BBS / BBM

Standard – Boring Tools  
Right Hand – Sharp (cont.)

Continued from previous page

Minimum Bore Diameter		Maximum Bore Depth	Projection	Centerline Offset	Shank Dia.	OAL	Uncoated		TIN Coated		AITIN Coated	
D1	decimal equiv.	L2 +.050" -.000" +1.24mm -.00mm	P	F	D2 (h6)	L1	Tool #	Price	Tool #	Price	Tool #	Price
.100	.1000	.150	.025	.038	.1250	1.5	BB-100150S	23.60	BB-100150SG	25.50	BB-100150SX	26.10
.100	.1000	.200	.025	.038	.1250	1.5	BB-100200S	23.60	BB-100200SG	25.50	BB-100200SX	26.10
.100	.1000	.300	.025	.038	.1250	1.5	BB-100300S	23.60	BB-100300SG	25.50	BB-100300SX	26.10
.100	.1000	.400	.025	.038	.1250	1.5	BB-100400S	23.60	BB-100400SG	25.50	BB-100400SX	26.10
.100	.1000	.500	.025	.038	.1250	1.5	BB-100500S	23.60	BB-100500SG	25.50	BB-100500SX	26.10
.100	.1000	.600	.025	.038	.1250	1.5	BB-100600S	23.60	BB-100600SG	25.50	BB-100600SX	26.10
.100	.1000	.700	.025	.038	.1250	1.5	BB-100700S	23.60	BB-100700SG	25.50	BB-100700SX	26.10
.110	.1100	.150	.027	.048	.1250	1.5	BB-110150S	23.60	BB-110150SG	25.50	BB-110150SX	26.10
.110	.1100	.200	.027	.048	.1250	1.5	BB-110200S	23.60	BB-110200SG	25.50	BB-110200SX	26.10
.110	.1100	.300	.027	.048	.1250	1.5	BB-110300S	23.60	BB-110300SG	25.50	BB-110300SX	26.10
.110	.1100	.400	.027	.048	.1250	1.5	BB-110400S	23.60	BB-110400SG	25.50	BB-110400SX	26.10
.110	.1100	.500	.027	.048	.1250	1.5	BB-110500S	23.60	BB-110500SG	25.50	BB-110500SX	26.10
.110	.1100	.600	.027	.048	.1250	1.5	BB-110600S	23.60	BB-110600SG	25.50	BB-110600SX	26.10
.110	.1100	.700	.027	.048	.1250	1.5	BB-110700S	23.60	BB-110700SG	25.50	BB-110700SX	26.10
3 mm	.1181	8 mm	.75 mm	1 mm	4 mm	50 mm	BBM-040308	23.15	BBM-040308G	25.25	BBM-040308X	26.05
3 mm	.1181	10 mm	.75 mm	1 mm	4 mm	50 mm	BBM-040310	23.15	BBM-040310G	25.25	BBM-040310X	26.05
3 mm	.1181	13 mm	.75 mm	1 mm	4 mm	50 mm	BBM-040313	23.15	BBM-040313G	25.25	BBM-040313X	26.05
3 mm	.1181	15 mm	.75 mm	1 mm	4 mm	50 mm	BBM-040315	23.15	BBM-040315G	25.25	BBM-040315X	26.05
3 mm	.1181	20 mm	.75 mm	1 mm	4 mm	50 mm	BBM-040320	23.15	BBM-040320G	25.25	BBM-040320X	26.05
.120	.1200	.250	.030	.026	.1875	2.0	BB-120250S	25.20	BB-120250SG	27.30	BB-120250SX	28.10
.120	.1200	.350	.030	.026	.1875	2.0	BB-120350S	25.20	BB-120350SG	27.30	BB-120350SX	28.10
.120	.1200	.500	.030	.026	.1875	2.0	BB-120500S	25.20	BB-120500SG	27.30	BB-120500SX	28.10
.120	.1200	.600	.030	.026	.1875	2.0	BB-120600S	25.20	BB-120600SG	27.30	BB-120600SX	28.10
.120	.1200	.700	.030	.026	.1875	2.0	BB-120700S	25.20	BB-120700SG	27.30	BB-120700SX	28.10
.120	.1200	.800	.030	.026	.1875	2.0	BB-120800S	25.20	BB-120800SG	27.30	BB-120800SX	28.10
.140	.1400	.250	.035	.046	.1875	2.0	BB-140250S	25.20	BB-140250SG	27.30	BB-140250SX	28.10
.140	.1400	.400	.035	.046	.1875	2.0	BB-140400S	25.20	BB-140400SG	27.30	BB-140400SX	28.10
.140	.1400	.500	.035	.046	.1875	2.0	BB-140500S	25.20	BB-140500SG	27.30	BB-140500SX	28.10
.140	.1400	.600	.035	.046	.1875	2.0	BB-140600S	25.20	BB-140600SG	27.30	BB-140600SX	28.10
.140	.1400	.700	.035	.046	.1875	2.0	BB-140700S	25.20			BB-140700SX	28.10
.140	.1400	.750	.035	.046	.1875	2.0	BB-140750S	25.20	BB-140750SG	27.30	BB-140750SX	28.10
.140	.1400	.800	.035	.046	.1875	2.0	BB-140800S	25.20	BB-140800SG	27.30	BB-140800SX	28.10
4 mm	.1575	8 mm	1 mm	2 mm	4 mm	50 mm	BBM-040408	23.15	BBM-040408G	25.25	BBM-040408X	26.05
4 mm	.1575	10 mm	1 mm	2 mm	4 mm	50 mm	BBM-040410	23.15	BBM-040410G	25.25	BBM-040410X	26.05
4 mm	.1575	15 mm	1 mm	2 mm	4 mm	50 mm	BBM-040415	23.15	BBM-040415G	25.25	BBM-040415X	26.05
4 mm	.1575	20 mm	1 mm	2 mm	4 mm	50 mm	BBM-040420	23.15	BBM-040420G	25.25	BBM-040420X	26.05
4 mm	.1575	25 mm	1 mm	2 mm	4 mm	50 mm	BBM-040425	23.15	BBM-040425G	25.25	BBM-040425X	26.05
.160	.1600	.250	.040	.066	.1875	2.0	BB-160250S	25.20	BB-160250SG	27.30	BB-160250SX	28.10
.160	.1600	.400	.040	.066	.1875	2.0	BB-160400S	25.20	BB-160400SG	27.30	BB-160400SX	28.10
.160	.1600	.500	.040	.066	.1875	2.0	BB-160500S	25.20	BB-160500SG	27.30	BB-160500SX	28.10
.160	.1600	.600	.040	.066	.1875	2.0	BB-160600S	25.20	BB-160600SG	27.30	BB-160600SX	28.10
.160	.1600	.750	.040	.066	.1875	2.0	BB-160750S	25.20	BB-160750SG	27.30	BB-160750SX	28.10
.160	.1600	.900	.040	.066	.1875	2.0	BB-160900S	25.20	BB-160900SG	27.30	BB-160900SX	28.10
.160	.1600	1.000	.040	.066	.1875	2.0	BB-1601000S	25.20	BB-1601000SG	27.30	BB-1601000SX	28.10

Continued on next page

# Standard – Boring Tools

## Right Hand – Sharp (cont.)

BBS / BBM

Continued from previous page

Minimum Bore Diameter		Maximum Bore Depth	Projection	Centerline Offset	Shank Dia.	OAL	Uncoated		TIN Coated		AITIN Coated	
D1	decimal equiv.	L2 +.050" -.000" +1.24mm -.00mm	P	F	D2 (h6)	L1	Tool #	Price	Tool #	Price	Tool #	Price
.180	.1800	.350	.045	.055	.2500	2.5	BB-180350S	27.20	BB-180350SG	30.50	BB-180350SX	32.10
.180	.1800	.500	.045	.055	.2500	2.5	BB-180500S	27.20	BB-180500SG	30.50	BB-180500SX	32.10
.180	.1800	.600	.045	.055	.2500	2.5	BB-180600S	27.20	BB-180600SG	30.50	BB-180600SX	32.10
.180	.1800	.750	.045	.055	.2500	2.5	BB-180750S	27.20	BB-180750SG	30.50	BB-180750SX	32.10
.180	.1800	.900	.045	.055	.2500	2.5	BB-180900S	27.20	BB-180900SG	30.50	BB-180900SX	32.10
.180	.1800	1.000	.045	.055	.2500	2.5	BB-1801000S	27.20	BB-1801000SG	30.50	BB-1801000SX	32.10
.180	.1800	1.100	.045	.055	.2500	2.5	BB-1801100S	27.20	BB-1801100SG	30.50	BB-1801100SX	32.10
.180	.1800	1.250	.045	.055	.2500	2.5	BB-1801250S	27.20	BB-1801250SG	30.50	BB-1801250SX	32.10
.180	.1800	1.500	.045	.055	.2500	2.5	BB-1801500S	27.20	BB-1801500SG	30.50	BB-1801500SX	32.10
5 mm	.1969	10 mm	1.25 mm	2 mm	6 mm	57 mm	BBM-060510	25.90	BBM-060510G	29.20	BBM-060510X	30.80
5 mm	.1969	15 mm	1.25 mm	2 mm	6 mm	57 mm	BBM-060515	25.90	BBM-060515G	29.20	BBM-060515X	30.80
5 mm	.1969	20 mm	1.25 mm	2 mm	6 mm	57 mm	BBM-060520	25.90	BBM-060520G	29.20	BBM-060520X	30.80
5 mm	.1969	25 mm	1.25 mm	2 mm	6 mm	57 mm	BBM-060525	25.90			BBM-060525X	30.80
5 mm	.1969	28 mm	1.25 mm	2 mm	6 mm	57 mm	BBM-060528	25.90	BBM-060528G	29.20	BBM-060528X	30.80
.200	.2000	.400	.050	.075	.2500	2.5	BB-200400S	27.20	BB-200400SG	30.50	BB-200400SX	32.10
.200	.2000	.500	.050	.075	.2500	2.5	BB-200500S	27.20	BB-200500SG	30.50	BB-200500SX	32.10
.200	.2000	.600	.050	.075	.2500	2.5	BB-200600S	27.20	BB-200600SG	30.50	BB-200600SX	32.10
.200	.2000	.700	.050	.075	.2500	2.5	BB-200700S	27.20	BB-200700SG	30.50	BB-200700SX	32.10
.200	.2000	.800	.050	.075	.2500	2.5	BB-200800S	27.20	BB-200800SG	30.50	BB-200800SX	32.10
.200	.2000	.900	.050	.075	.2500	2.5	BB-200900S	27.20	BB-200900SG	30.50	BB-200900SX	32.10
.200	.2000	1.000	.050	.075	.2500	2.5	BB-2001000S	27.20	BB-2001000SG	30.50	BB-2001000SX	32.10
.200	.2000	1.100	.050	.075	.2500	2.5	BB-2001100S	27.20			BB-2001100SX	32.10
.200	.2000	1.200	.050	.075	.2500	2.5	BB-2001200S	27.20			BB-2001200SX	32.10
.200	.2000	1.300	.050	.075	.2500	2.5	BB-2001300S	27.20			BB-2001300SX	32.10
.230	.2300	.400	.057	.074	.3125	2.5	BB-230400S	37.30	BB-230400SG	42.20	BB-230400SX	44.10
.230	.2300	.500	.057	.074	.3125	2.5	BB-230500S	37.30	BB-230500SG	42.20	BB-230500SX	44.10
.230	.2300	.600	.057	.074	.3125	2.5	BB-230600S	37.30	BB-230600SG	42.20	BB-230600SX	44.10
.230	.2300	.700	.057	.074	.3125	2.5	BB-230700S	37.30	BB-230700SG	42.20	BB-230700SX	44.10
.230	.2300	.800	.057	.074	.3125	2.5	BB-230800S	37.30	BB-230800SG	42.20	BB-230800SX	44.10
.230	.2300	.900	.057	.074	.3125	2.5	BB-230900S	37.30	BB-230900SG	42.20	BB-230900SX	44.10
.230	.2300	1.000	.057	.074	.3125	2.5	BB-2301000S	37.30	BB-2301000SG	42.20	BB-2301000SX	44.10
.230	.2300	1.100	.057	.074	.3125	2.5	BB-2301100S	37.30	BB-2301100SG	42.20	BB-2301100SX	44.10
.230	.2300	1.150	.057	.074	.3125	2.5	BB-2301150S	37.30	BB-2301150SG	42.20	BB-2301150SX	44.10
.230	.2300	1.200	.057	.074	.3125	2.5	BB-2301200S	37.30	BB-2301200SG	42.20	BB-2301200SX	44.10
.230	.2300	1.250	.057	.074	.3125	2.5	BB-2301250S	37.30	BB-2301250SG	42.20	BB-2301250SX	44.10
.230	.2300	1.400	.057	.074	.3125	2.5	BB-2301400S	37.30	BB-2301400SG	42.20	BB-2301400SX	44.10
.230	.2300	1.500	.057	.074	.3125	2.5	BB-2301500S	37.30	BB-2301500SG	42.20	BB-2301500SX	44.10
.230	.2300	1.600	.057	.074	.3125	2.5	BB-2301600S	37.30	BB-2301600SG	42.20	BB-2301600SX	44.10
6 mm	.2362	10 mm	1.50 mm	3 mm	6 mm	57 mm	BBM-060610	25.90	BBM-060610G	29.20	BBM-060610X	30.80
6 mm	.2362	15 mm	1.50 mm	3 mm	6 mm	57 mm	BBM-060615	25.90	BBM-060615G	29.20	BBM-060615X	30.80
6 mm	.2362	20 mm	1.50 mm	3 mm	6 mm	57 mm	BBM-060620	25.90			BBM-060620X	30.80
6 mm	.2362	25 mm	1.50 mm	3 mm	6 mm	57 mm	BBM-060625	25.90	BBM-060625G	29.20	BBM-060625X	30.80
6 mm	.2362	30 mm	1.50 mm	3 mm	6 mm	57 mm	BBM-060630	25.90	BBM-060630G	29.20	BBM-060630X	30.80
6 mm	.2362	35 mm	1.50 mm	3 mm	6 mm	57 mm	BBM-060635	25.90	BBM-060635G	29.20	BBM-060635X	30.80
6 mm	.2362	38 mm	1.50 mm	3 mm	6 mm	57 mm	BBM-060638	25.90	BBM-060638G	29.20	BBM-060638X	30.80

Continued on next page

Standard – Boring Tools



## BBS / BBM

Standard – Boring Tools  
Right Hand – Sharp (cont.)

Continued from previous page

Minimum Bore Diameter		Maximum Bore Depth	Projection	Centerline Offset	Shank Dia.	OAL	Uncoated		TIN Coated		AITIN Coated	
D <sub>1</sub>	decimal equiv.	L <sub>2</sub> +.050" -.000" +1.24mm -.00mm	P	F	D <sub>2</sub> (h6)	L <sub>1</sub>	Tool #	Price	Tool #	Price	Tool #	Price
7 mm	.2755	15 mm	1.75 mm	3 mm	8 mm	63 mm	BBM-080715	35.40	BBM-080715G	40.30	BBM-080715X	42.20
7 mm	.2755	20 mm	1.75 mm	3 mm	8 mm	63 mm	BBM-080720	35.40			BBM-080720X	42.20
7 mm	.2755	25 mm	1.75 mm	3 mm	8 mm	63 mm	BBM-080725	35.40			BBM-080725X	42.20
7 mm	.2755	32 mm	1.75 mm	3 mm	8 mm	63 mm	BBM-080732	35.40	BBM-080732G	40.30	BBM-080732X	42.20
7 mm	.2755	38 mm	1.75 mm	3 mm	8 mm	63 mm	BBM-080738	35.40	BBM-080738G	40.30	BBM-080738X	42.20
7 mm	.2755	46 mm	1.75 mm	3 mm	8 mm	63 mm	BBM-080746	35.40	BBM-080746G	40.30	BBM-080746X	42.20
.290	.2900	.500	.072	.134	.3125	2.5	BB-290500S	37.30	BB-290500SG	42.20	BB-290500SX	44.10
.290	.2900	.600	.072	.134	.3125	2.5	BB-290600S	37.30	BB-290600SG	42.20	BB-290600SX	44.10
.290	.2900	.750	.072	.134	.3125	2.5	BB-290750S	37.30	BB-290750SG	42.20	BB-290750SX	44.10
.290	.2900	.900	.072	.134	.3125	2.5	BB-290900S	37.30	BB-290900SG	42.20	BB-290900SX	44.10
.290	.2900	1.000	.072	.134	.3125	2.5	BB-2901000S	37.30	BB-2901000SG	42.20	BB-2901000SX	44.10
.290	.2900	1.100	.072	.134	.3125	2.5	BB-2901100S	37.30	BB-2901100SG	42.20	BB-2901100SX	44.10
.290	.2900	1.250	.072	.134	.3125	2.5	BB-2901250S	37.30	BB-2901250SG	42.20	BB-2901250SX	44.10
.290	.2900	1.350	.072	.134	.3125	2.5	BB-2901350S	37.30	BB-2901350SG	42.20	BB-2901350SX	44.10
.290	.2900	1.500	.072	.134	.3125	2.5	BB-2901500S	37.30	BB-2901500SG	42.20	BB-2901500SX	44.10
.290	.2900	1.600	.072	.134	.3125	2.5	BB-2901600S	37.30	BB-2901600SG	42.20	BB-2901600SX	44.10
.290	.2900	1.750	.072	.134	.3125	2.5	BB-2901750S	37.30	BB-2901750SG	42.20	BB-2901750SX	44.10
8 mm	.3150	13 mm	2 mm	4 mm	8 mm	63 mm	BBM-080813	35.40	BBM-080813G	40.30	BBM-080813X	42.20
8 mm	.3150	20 mm	2 mm	4 mm	8 mm	63 mm	BBM-080820	35.40	BBM-080820G	40.30	BBM-080820X	42.20
8 mm	.3150	25 mm	2 mm	4 mm	8 mm	63 mm	BBM-080825	35.40	BBM-080825G	40.30	BBM-080825X	42.20
8 mm	.3150	32 mm	2 mm	4 mm	8 mm	63 mm	BBM-080832	35.40	BBM-080832G	40.30	BBM-080832X	42.20
8 mm	.3150	38 mm	2 mm	4 mm	8 mm	63 mm	BBM-080838	35.40	BBM-080838G	40.30	BBM-080838X	42.20
8 mm	.3150	46 mm	2 mm	4 mm	8 mm	63 mm	BBM-080846	35.40	BBM-080846G	40.30	BBM-080846X	42.20
8 mm	.3150	50 mm	2 mm	4 mm	8 mm	63 mm	BBM-080850	35.40	BBM-080850G	40.30	BBM-080850X	42.20
.320	.3200	.500	.080	.133	.3750	2.5	BB-320500S	51.35	BB-320500SG	56.25	BB-320500SX	58.15
.320	.3200	.600	.080	.133	.3750	2.5	BB-320600S	51.35	BB-320600SG	56.25	BB-320600SX	58.15
.320	.3200	.750	.080	.133	.3750	2.5	BB-320750S	51.35	BB-320750SG	56.25	BB-320750SX	58.15
.320	.3200	.900	.080	.133	.3750	2.5	BB-320900S	51.35			BB-320900SX	58.15
.320	.3200	1.000	.080	.133	.3750	2.5	BB-3201000S	51.35	BB-3201000SG	56.25	BB-3201000SX	58.15
.320	.3200	1.100	.080	.133	.3750	2.5	BB-3201100S	51.35	BB-3201100SG	56.25	BB-3201100SX	58.15
.320	.3200	1.250	.080	.133	.3750	2.5	BB-3201250S	51.35	BB-3201250SG	56.25	BB-3201250SX	58.15
.320	.3200	1.500	.080	.133	.3750	2.5	BB-3201500S	51.35	BB-3201500SG	56.25	BB-3201500SX	58.15
.320	.3200	1.600	.080	.133	.3750	2.5	BB-3201600S	51.35	BB-3201600SG	56.25	BB-3201600SX	58.15
.320	.3200	1.800	.080	.133	.3750	2.5	BB-3201800S	51.35	BB-3201800SG	56.25	BB-3201800SX	58.15
.320	.3200	2.000	.080	.133	.3750	4.0	BB-3202000S	65.95	BB-3202000SG	71.85	BB-3202000SX	74.35
.320	.3200	2.500	.080	.133	.3750	4.0	BB-3202500S	65.95	BB-3202500SG	71.85	BB-3202500SX	74.35
.320	.3200	3.000	.080	.133	.3750	4.0	BB-3203000S	65.95	BB-3203000SG	71.85	BB-3203000SX	74.35
9 mm	.3543	13 mm	2.25 mm	4 mm	10 mm	72 mm			BBM-100913G	58.60		
9 mm	.3543	25 mm	2.25 mm	4mm	10 mm	72 mm	BBM-100925	53.60	BBM-100925G	58.60	BBM-100925X	60.40
9 mm	.3543	32 mm	2.25 mm	4mm	10 mm	72 mm	BBM-100932	53.60	BBM-100932G	58.60	BBM-100932X	60.40
9 mm	.3543	38 mm	2.25 mm	4mm	10 mm	72 mm	BBM-100938	53.60	BBM-100938G	58.60	BBM-100938X	60.40
9 mm	.3543	46 mm	2.25 mm	4mm	10 mm	72 mm	BBM-100946	53.60	BBM-100946G	58.60	BBM-100946X	60.40
9 mm	.3543	50 mm	2.25 mm	4mm	10 mm	72 mm	BBM-100950	53.60			BBM-100950X	60.40

Continued on next page

# Standard – Boring Tools

BBS / BBM

## Right Hand – Sharp (cont.)

Continued from previous page

Minimum Bore Diameter		Maximum Bore Depth	Projection	Centerline Offset	Shank Dia.	OAL	Uncoated		TIN Coated		AITIN Coated	
D <sub>1</sub>	decimal equiv.	L <sub>2</sub> +.050" -.000" +1.24mm -.00mm	P	F	D <sub>2</sub> (h6)	L <sub>1</sub>	Tool #	Price	Tool #	Price	Tool #	Price
.360	.3600	.500	.090	.173	.3750	2.5	BB-360500S	51.35	BB-360500SG	56.25	BB-360500SX	58.15
.360	.3600	.600	.090	.173	.3750	2.5	BB-360600S	51.35	BB-360600SG	56.25	BB-360600SX	58.15
.360	.3600	.750	.090	.173	.3750	2.5	BB-360750S	51.35	BB-360750SG	56.25	BB-360750SX	58.15
.360	.3600	.900	.090	.173	.3750	2.5	BB-360900S	51.35	BB-360900SG	56.25	BB-360900SX	58.15
.360	.3600	1.000	.090	.173	.3750	2.5	BB-3601000S	51.35	BB-3601000SG	56.25	BB-3601000SX	58.15
.360	.3600	1.150	.090	.173	.3750	2.5	BB-3601150S	51.35	BB-3601150SG	56.25	BB-3601150SX	58.15
.360	.3600	1.250	.090	.173	.3750	2.5	BB-3601250S	51.35	BB-3601250SG	56.25	BB-3601250SX	58.15
.360	.3600	1.500	.090	.173	.3750	2.5	BB-3601500S	51.35	BB-3601500SG	56.25	BB-3601500SX	58.15
.360	.3600	1.600	.090	.173	.3750	2.5	BB-3601600S	51.35	BB-3601600SG	56.25	BB-3601600SX	58.15
.360	.3600	1.800	.090	.173	.3750	2.5	BB-3601800S	51.35	BB-3601800SG	56.25	BB-3601800SX	58.15
.360	.3600	2.000	.090	.173	.3750	4.0	BB-3602000S	65.95	BB-3602000SG	71.85	BB-3602000SX	74.35
.360	.3600	2.500	.090	.173	.3750	4.0	BB-3602500S	65.95	BB-3602500SG	71.85	BB-3602500SX	74.35
.360	.3600	3.000	.090	.173	.3750	4.0	BB-3603000S	65.95			BB-3603000SX	74.35
10 mm	.3937	15 mm	2.50 mm	5 mm	10 mm	72 mm	BBM-101015	53.60	BBM-101015G	58.60	BBM-101015X	60.40
10 mm	.3937	20 mm	2.50 mm	5 mm	10 mm	72 mm	BBM-101020	53.60	BBM-101020G	58.60		
10 mm	.3937	25 mm	2.50 mm	5 mm	10 mm	72 mm	BBM-101025	53.60	BBM-101025G	58.60	BBM-101025X	60.40
10 mm	.3937	32 mm	2.50 mm	5 mm	10 mm	72 mm	BBM-101032	53.60	BBM-101032G	58.60	BBM-101032X	60.40
10 mm	.3937	38 mm	2.50 mm	5 mm	10 mm	72 mm	BBM-101038	53.60	BBM-101038G	58.60	BBM-101038X	60.40
10 mm	.3937	50 mm	2.50 mm	5 mm	10 mm	72 mm	BBM-101050	53.60	BBM-101050G	58.60	BBM-101050X	60.40
11 mm	.4331	15 mm	2.75 mm	5 mm	12 mm	83 mm	BBM-121115	67.60				
11 mm	.4331	25 mm	2.75 mm	5 mm	12 mm	83 mm	BBM-121125	67.60				
11 mm	.4331	38 mm	2.75 mm	5 mm	12 mm	83 mm	BBM-121138	67.60	BBM-121138G	74.60		
11 mm	.4331	50 mm	2.75 mm	5 mm	12 mm	83 mm	BBM-121150	67.60	BBM-121150G	74.60		
12 mm	.4724	20 mm	3 mm	6 mm	12 mm	83 mm	BBM-121220	67.60	BBM-121220G	74.60	BBM-121220X	77.90
12 mm	.4724	32 mm	3 mm	6 mm	12 mm	83 mm	BBM-121232	67.60	BBM-121232G	74.60	BBM-121232X	77.90
12 mm	.4724	46 mm	3 mm	6 mm	12 mm	83 mm	BBM-121246	67.60	BBM-121246G	74.60	BBM-121246X	77.90
12 mm	.4724	60 mm	3 mm	6 mm	12 mm	83 mm	BBM-121260	67.60	BBM-121260G	74.60	BBM-121260X	77.90
.490	.4900	.750	.122	.240	.5000	3.0	BB-490750S	72.10	BB-490750SG	77.90	BB-490750SX	80.30
.490	.4900	1.000	.122	.240	.5000	3.0	BB-4901000S	72.10			BB-4901000SX	80.30
.490	.4900	1.250	.122	.240	.5000	3.0	BB-4901250S	72.10	BB-4901250SG	77.90	BB-4901250SX	80.30
.490	.4900	1.500	.122	.240	.5000	3.0	BB-4901500S	72.10			BB-4901500SX	80.30
.490	.4900	2.000	.122	.240	.5000	4.0	BB-4902000S	79.10	BB-4902000SG	86.10	BB-4902000SX	89.40
.490	.4900	2.500	.122	.240	.5000	4.0	BB-4902500S	79.10	BB-4902500SG	86.10	BB-4902500SX	89.40
.490	.4900	2.750	.122	.240	.5000	4.0	BB-4902750S	79.10	BB-4902750SG	86.10	BB-4902750SX	89.40
.490	.4900	3.000	.122	.240	.5000	6.0	BB-4903000S	99.80			BB-4903000SX	113.80
.490	.4900	3.500	.122	.240	.5000	6.0	BB-4903500S	99.80	BB-4903500SG	109.00	BB-4903500SX	113.80
.490	.4900	4.000	.122	.240	.5000	6.0	BB-4904000S	99.80			BB-4904000SX	113.80
.490	.4900	4.500	.122	.240	.5000	6.0	BB-4904500S	99.80			BB-4904500SX	113.80

Standard – Boring Tools

BB

Standard – Boring Tools  
Right Hand

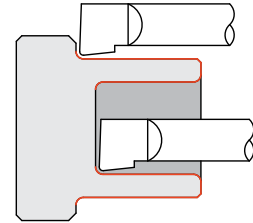
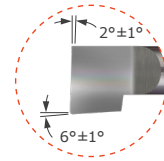
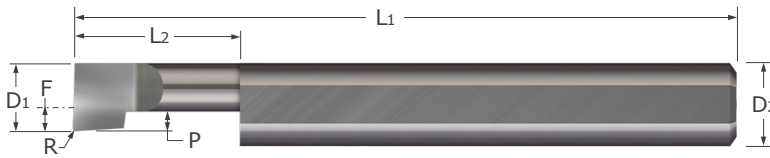

- Designed for facing and boring applications in bores .050" and larger
- Polished split face for improved edge retention and chip evacuation while reducing galling
- Split geometry makes the tool as rigid as possible
- Corner radius profile
- Lockdown flat automatically locates tool on center
- Coating options provide added lubricity and increased wear resistance in difficult to machine materials
- Solid carbide ■ CNC ground in the USA

Minimum Bore Dia.	Maximum Bore Depth	Radius	Projection	Centerline Offset	Shank Dia.	OAL	Uncoated		TIN Coated		AITIN Coated	
D1	L2 <sup>+0.050"</sup> <sub>-.000"</sub>	R <sup>+0.003"</sup> <sub>-.000"</sub>	P	F	D2 (h6)	L1	Tool #	Price	Tool #	Price	Tool #	Price
.050	.150	.003	.012	-.013	.1250	1.5	BB-050150	25.10	BB-050150G	27.00	BB-050150X	27.60
.050	.200	.003	.012	-.013	.1250	1.5	BB-050200	25.10	BB-050200G	27.00	BB-050200X	27.60
.050	.300	.003	.012	-.013	.1250	1.5	BB-050300	25.10	BB-050300G	27.00	BB-050300X	27.60
.050	.400	.003	.012	-.013	.1250	1.5	BB-050400	25.10	BB-050400G	27.00	BB-050400X	27.60
.060	.150	.003	.015	-.003	.1250	1.5	BB-060150	25.10	BB-060150G	27.00	BB-060150X	27.60
.060	.200	.003	.015	-.003	.1250	1.5	BB-060200	25.10	BB-060200G	27.00	BB-060200X	27.60
.060	.300	.003	.015	-.003	.1250	1.5	BB-060300	25.10	BB-060300G	27.00	BB-060300X	27.60
.060	.400	.003	.015	-.003	.1250	1.5	BB-060400	25.10	BB-060400G	27.00	BB-060400X	27.60
.060	.500	.003	.015	-.003	.1250	1.5	BB-060500	25.10	BB-060500G	27.00	BB-060500X	27.60
.070	.150	.003	.015	.008	.1250	1.5	BB-070150	25.10			BB-070150X	27.60
.070	.200	.003	.015	.008	.1250	1.5	BB-070200	25.10			BB-070200X	27.60
.070	.300	.003	.015	.008	.1250	1.5	BB-070300	25.10			BB-070300X	27.60
.080	.150	.003	.020	.018	.1250	1.5	BB-080150	25.10	BB-080150G	27.00	BB-080150X	27.60
.080	.200	.003	.020	.018	.1250	1.5	BB-080200	25.10	BB-080200G	27.00	BB-080200X	27.60
.080	.300	.003	.020	.018	.1250	1.5	BB-080300	25.10	BB-080300G	27.00	BB-080300X	27.60
.080	.400	.003	.020	.018	.1250	1.5	BB-080400	25.10	BB-080400G	27.00	BB-080400X	27.60
.080	.500	.003	.020	.018	.1250	1.5	BB-080500	25.10	BB-080500G	27.00	BB-080500X	27.60
.080	.600	.003	.020	.018	.1250	1.5	BB-080600	25.10	BB-080600G	27.00	BB-080600X	27.60
.090	.300	.003	.020	.028	.1250	1.5	BB-090300	25.10			BB-090300X	27.60
.100	.150	.003	.025	.038	.1250	1.5	BB-100150	25.10	BB-100150G	27.00	BB-100150X	27.60
.100	.200	.003	.025	.038	.1250	1.5	BB-100200	25.10	BB-100200G	27.00	BB-100200X	27.60
.100	.300	.003	.025	.038	.1250	1.5	BB-100300	25.10	BB-100300G	27.00	BB-100300X	27.60
.100	.400	.003	.025	.038	.1250	1.5	BB-100400	25.10	BB-100400G	27.00	BB-100400X	27.60
.100	.500	.003	.025	.038	.1250	1.5	BB-100500	25.10	BB-100500G	27.00	BB-100500X	27.60
.100	.600	.003	.025	.038	.1250	1.5	BB-100600	25.10	BB-100600G	27.00	BB-100600X	27.60
.100	.700	.003	.025	.038	.1250	1.5	BB-100700	25.10	BB-100700G	27.00	BB-100700X	27.60

Continued on next page

Standard – Boring Tools

# Standard – Boring Tools

BB

## Right Hand (cont.)

Continued from previous page

Minimum Bore Dia.	Maximum Bore Depth	Radius	Projection	Centerline Offset	Shank Dia.	OAL	Uncoated		TiN Coated		AlTiN Coated	
D1	L2 <sup>+ .050"</sup> <sub>-.000"</sub>	R <sup>+ .003"</sup> <sub>-.000"</sub>	P	F	D2 (h6)	L1	Tool #	Price	Tool #	Price	Tool #	Price
.110	.150	.003	.027	.048	.1250	1.5	BB-110150	25.10	BB-110150G	27.00	BB-110150X	27.60
.110	.200	.003	.027	.048	.1250	1.5	BB-110200	25.10	BB-110200G	27.00	BB-110200X	27.60
.110	.300	.003	.027	.048	.1250	1.5	BB-110300	25.10	BB-110300G	27.00	BB-110300X	27.60
.110	.400	.003	.027	.048	.1250	1.5	BB-110400	25.10	BB-110400G	27.00	BB-110400X	27.60
.110	.500	.003	.027	.048	.1250	1.5	BB-110500	25.10	BB-110500G	27.00	BB-110500X	27.60
.110	.600	.003	.027	.048	.1250	1.5	BB-110600	25.10	BB-110600G	27.00	BB-110600X	27.60
.110	.700	.003	.027	.048	.1250	1.5	BB-110700	25.10	BB-110700G	27.00	BB-110700X	27.60

D1	L2 <sup>+ .050"</sup> <sub>-.000"</sub>	R <sup>+ .002"</sup> <sub>-.000"</sub>	P	F	D2 (h6)	L1	Tool #	Price	Tool #	Price	Tool #	Price
.120	.250	.006	.030	.026	.1875	2.0	BB-120250	26.65	BB-120250G	28.75	BB-120250X	29.55
.120	.350	.006	.030	.026	.1875	2.0	BB-120350	26.65	BB-120350G	28.75	BB-120350X	29.55
.120	.500	.006	.030	.026	.1875	2.0	BB-120500	26.65	BB-120500G	28.75	BB-120500X	29.55
.120	.600	.006	.030	.026	.1875	2.0	BB-120600	26.65	BB-120600G	28.75	BB-120600X	29.55
.120	.700	.006	.030	.026	.1875	2.0	BB-120700	26.65	BB-120700G	28.75	BB-120700X	29.55
.120	.800	.006	.030	.026	.1875	2.0	BB-120800	26.65	BB-120800G	28.75	BB-120800X	29.55
.140	.250	.006	.035	.046	.1875	2.0	BB-140250	26.65	BB-140250G	28.75	BB-140250X	29.55
.140	.400	.006	.035	.046	.1875	2.0	BB-140400	26.65	BB-140400G	28.75	BB-140400X	29.55
.140	.500	.006	.035	.046	.1875	2.0	BB-140500	26.65	BB-140500G	28.75	BB-140500X	29.55
.140	.600	.006	.035	.046	.1875	2.0	BB-140600	26.65	BB-140600G	28.75	BB-140600X	29.55
.140	.700	.006	.035	.046	.1875	2.0	BB-140700	26.65	BB-140700G	28.75	BB-140700X	29.55
.140	.750	.006	.035	.046	.1875	2.0	BB-140750	26.65	BB-140750G	28.75	BB-140750X	29.55
.140	.800	.006	.035	.046	.1875	2.0	BB-140800	26.65	BB-140800G	28.75	BB-140800X	29.55
.160	.250	.006	.040	.066	.1875	2.0	BB-160250	26.65	BB-160250G	28.75	BB-160250X	29.55
.160	.400	.006	.040	.066	.1875	2.0	BB-160400	26.65	BB-160400G	28.75	BB-160400X	29.55
.160	.500	.006	.040	.066	.1875	2.0	BB-160500	26.65	BB-160500G	28.75	BB-160500X	29.55
.160	.600	.006	.040	.066	.1875	2.0	BB-160600	26.65	BB-160600G	28.75	BB-160600X	29.55
.160	.750	.006	.040	.066	.1875	2.0	BB-160750	26.65	BB-160750G	28.75	BB-160750X	29.55
.160	.900	.006	.040	.066	.1875	2.0	BB-160900	26.65	BB-160900G	28.75	BB-160900X	29.55
.160	1.000	.006	.040	.066	.1875	2.0	BB-1601000	26.65	BB-1601000G	28.75	BB-1601000X	29.55
.180	.350	.006	.045	.055	.2500	2.5	BB-180350	28.80	BB-180350G	32.10	BB-180350X	33.70
.180	.500	.006	.045	.055	.2500	2.5	BB-180500	28.80	BB-180500G	32.10	BB-180500X	33.70
.180	.600	.006	.045	.055	.2500	2.5	BB-180600	28.80	BB-180600G	32.10	BB-180600X	33.70
.180	.750	.006	.045	.055	.2500	2.5	BB-180750	28.80	BB-180750G	32.10	BB-180750X	33.70
.180	.900	.006	.045	.055	.2500	2.5	BB-180900	28.80	BB-180900G	32.10	BB-180900X	33.70
.180	1.000	.006	.045	.055	.2500	2.5	BB-1801000	28.80	BB-1801000G	32.10	BB-1801000X	33.70
.180	1.100	.006	.045	.055	.2500	2.5	BB-1801100	28.80	BB-1801100G	32.10	BB-1801100X	33.70
.180	1.250	.006	.045	.055	.2500	2.5	BB-1801250	28.80	BB-1801250G	32.10	BB-1801250X	33.70
.180	1.500	.006	.045	.055	.2500	2.5	BB-1801500	28.80	BB-1801500G	32.10	BB-1801500X	33.70
.200	.400	.006	.050	.075	.2500	2.5	BB-200400	28.80	BB-200400G	32.10	BB-200400X	33.70
.200	.500	.006	.050	.075	.2500	2.5	BB-200500	28.80	BB-200500G	32.10	BB-200500X	33.70
.200	.600	.006	.050	.075	.2500	2.5	BB-200600	28.80	BB-200600G	32.10	BB-200600X	33.70
.200	.700	.006	.050	.075	.2500	2.5	BB-200700	28.80	BB-200700G	32.10	BB-200700X	33.70
.200	.800	.006	.050	.075	.2500	2.5	BB-200800	28.80	BB-200800G	32.10	BB-200800X	33.70
.200	.900	.006	.050	.075	.2500	2.5	BB-200900	28.80	BB-200900G	32.10	BB-200900X	33.70
.200	1.000	.006	.050	.075	.2500	2.5	BB-2001000	28.80	BB-2001000G	32.10	BB-2001000X	33.70
.200	1.100	.006	.050	.075	.2500	2.5	BB-2001100	28.80			BB-2001100X	33.70
.200	1.200	.006	.050	.075	.2500	2.5	BB-2001200	28.80	BB-2001200G	32.10	BB-2001200X	33.70
.200	1.300	.006	.050	.075	.2500	2.5	BB-2001300	28.80	BB-2001300G	32.10	BB-2001300X	33.70

Standard – Boring Tools

## BB

Standard – Boring Tools  
Right Hand (cont.)

Continued from previous page

Minimum Bore Dia.		Maximum Bore Depth	Radius	Projection	Centerline Offset	Shank Dia.	OAL	Uncoated		TiN Coated		AlTiN Coated	
D1	L2	$\begin{matrix} +.050" \\ -.000" \end{matrix}$	$\begin{matrix} +.002" \\ -.000" \end{matrix}$	P	F	D2 (h6)	L1	Tool #	Price	Tool #	Price	Tool #	Price
.230	.400		.006	.057	.074	.3125	2.5	BB-230400	38.65	BB-230400G	43.55	BB-230400X	45.45
.230	.500		.006	.057	.074	.3125	2.5	BB-230500	38.65	BB-230500G	43.55	BB-230500X	45.45
.230	.600		.006	.057	.074	.3125	2.5	BB-230600	38.65	BB-230600G	43.55	BB-230600X	45.45
.230	.700		.006	.057	.074	.3125	2.5	BB-230700	38.65	BB-230700G	43.55	BB-230700X	45.45
.230	.800		.006	.057	.074	.3125	2.5	BB-230800	38.65	BB-230800G	43.55	BB-230800X	45.45
.230	.900		.006	.057	.074	.3125	2.5	BB-230900	38.65	BB-230900G	43.55	BB-230900X	45.45
.230	1.000		.006	.057	.074	.3125	2.5	BB-231000	38.65	BB-231000G	43.55	BB-231000X	45.45
.230	1.100		.006	.057	.074	.3125	2.5	BB-231100	38.65	BB-231100G	43.55	BB-231100X	45.45
.230	1.150		.006	.057	.074	.3125	2.5	BB-231150	38.65	BB-231150G	43.55	BB-231150X	45.45
.230	1.200		.006	.057	.074	.3125	2.5	BB-231200	38.65	BB-231200G	43.55	BB-231200X	45.45
.230	1.250		.006	.057	.074	.3125	2.5	BB-231250	38.65	BB-231250G	43.55	BB-231250X	45.45
.230	1.400		.006	.057	.074	.3125	2.5	BB-231400	38.65	BB-231400G	43.55	BB-231400X	45.45
.230	1.500		.006	.057	.074	.3125	2.5	BB-231500	38.65	BB-231500G	43.55	BB-231500X	45.45
.230	1.600		.006	.057	.074	.3125	2.5	BB-231600	38.65	BB-231600G	43.55	BB-231600X	45.45
.290	.500		.006	.072	.134	.3125	2.5	BB-290500	38.65	BB-290500G	43.55	BB-290500X	45.45
.290	.600		.006	.072	.134	.3125	2.5	BB-290600	38.65	BB-290600G	43.55	BB-290600X	45.45
.290	.750		.006	.072	.134	.3125	2.5	BB-290750	38.65	BB-290750G	43.55	BB-290750X	45.45
.290	.900		.006	.072	.134	.3125	2.5	BB-290900	38.65	BB-290900G	43.55	BB-290900X	45.45
.290	1.000		.006	.072	.134	.3125	2.5	BB-291000	38.65	BB-291000G	43.55	BB-291000X	45.45
.290	1.100		.006	.072	.134	.3125	2.5	BB-291100	38.65	BB-291100G	43.55	BB-291100X	45.45
.290	1.250		.006	.072	.134	.3125	2.5	BB-291250	38.65	BB-291250G	43.55	BB-291250X	45.45
.290	1.350		.006	.072	.134	.3125	2.5	BB-291350	38.65	BB-291350G	43.55	BB-291350X	45.45
.290	1.500		.006	.072	.134	.3125	2.5	BB-291500	38.65	BB-291500G	43.55	BB-291500X	45.45
.290	1.600		.006	.072	.134	.3125	2.5	BB-291600	38.65	BB-291600G	43.55	BB-291600X	45.45
.290	1.750		.006	.072	.134	.3125	2.5	BB-291750	38.65	BB-291750G	43.55	BB-291750X	45.45
.320	.500		.006	.080	.133	.3750	2.5	BB-320500	52.75	BB-320500G	57.65	BB-320500X	59.55
.320	.600		.006	.080	.133	.3750	2.5	BB-320600	52.75	BB-320600G	57.65	BB-320600X	59.55
.320	.750		.006	.080	.133	.3750	2.5	BB-320750	52.75	BB-320750G	57.65	BB-320750X	59.55
.320	.900		.006	.080	.133	.3750	2.5	BB-320900	52.75	BB-320900G	57.65	BB-320900X	59.55
.320	1.000		.006	.080	.133	.3750	2.5	BB-321000	52.75	BB-321000G	57.65	BB-321000X	59.55
.320	1.100		.006	.080	.133	.3750	2.5	BB-321100	52.75	BB-321100G	57.65	BB-321100X	59.55
.320	1.250		.006	.080	.133	.3750	2.5	BB-321250	52.75	BB-321250G	57.65	BB-321250X	59.55
.320	1.500		.006	.080	.133	.3750	2.5	BB-321500	52.75	BB-321500G	57.65	BB-321500X	59.55
.320	1.600		.006	.080	.133	.3750	2.5	BB-321600	52.75	BB-321600G	57.65	BB-321600X	59.55
.320	1.800		.006	.080	.133	.3750	2.5	BB-321800	52.75	BB-321800G	57.65	BB-321800X	59.55
.320	2.000		.006	.080	.133	.3750	4.0	BB-3202000	67.45	BB-3202000G	73.35	BB-3202000X	75.85
.320	2.500		.006	.080	.133	.3750	4.0	BB-3202500	67.45	BB-3202500G	73.35	BB-3202500X	75.85
.320	3.000		.006	.080	.133	.3750	4.0	BB-3203000	67.45			BB-3203000X	75.85

Continued on next page

# Standard – Boring Tools

BB

Right Hand (cont.)

Continued from previous page

Minimum Bore Dia.	Maximum Bore Depth	Radius	Projection	Centerline Offset	Shank Dia.	OAL	Uncoated		TIN Coated		AITIN Coated	
D <sub>1</sub>	L <sub>2</sub> <sup>+0.050"</sup> <sub>-.000"</sub>	R <sup>+0.002"</sup> <sub>-.000"</sub>	P	F	D <sub>2</sub> (h6)	L <sub>1</sub>	Tool #	Price	Tool #	Price	Tool #	Price
.360	.500	.006	.090	.173	.3750	2.5	BB-360500	52.75	BB-360500G	57.65	BB-360500X	59.55
.360	.600	.006	.090	.173	.3750	2.5	BB-360600	52.75	BB-360600G	57.65	BB-360600X	59.55
.360	.750	.006	.090	.173	.3750	2.5	BB-360750	52.75	BB-360750G	57.65	BB-360750X	59.55
.360	.900	.006	.090	.173	.3750	2.5	BB-360900	52.75	BB-360900G	57.65	BB-360900X	59.55
.360	1.000	.006	.090	.173	.3750	2.5	BB-3601000	52.75	BB-3601000G	57.65	BB-3601000X	59.55
.360	1.150	.006	.090	.173	.3750	2.5	BB-3601150	52.75	BB-3601150G	57.65	BB-3601150X	59.55
.360	1.250	.006	.090	.173	.3750	2.5	BB-3601250	52.75	BB-3601250G	57.65	BB-3601250X	59.55
.360	1.500	.006	.090	.173	.3750	2.5	BB-3601500	52.75	BB-3601500G	57.65	BB-3601500X	59.55
.360	1.600	.006	.090	.173	.3750	2.5	BB-3601600	52.75	BB-3601600G	57.65	BB-3601600X	59.55
.360	1.800	.006	.090	.173	.3750	2.5	BB-3601800	52.75	BB-3601800G	57.65	BB-3601800X	59.55
.360	2.000	.006	.090	.173	.3750	4.0	BB-3602000	67.45	BB-3602000G	73.35	BB-3602000X	75.85
.360	2.500	.006	.090	.173	.3750	4.0	BB-3602500	67.45	BB-3602500G	73.35	BB-3602500X	75.85
.360	3.000	.006	.090	.173	.3750	4.0	BB-3603000	67.45	BB-3603000G	73.35	BB-3603000X	75.85
.490	.750	.006	.122	.240	.5000	3.0	BB-490750	73.50	BB-490750G	79.30	BB-490750X	81.70
.490	1.000	.006	.122	.240	.5000	3.0	BB-4901000	73.50	BB-4901000G	79.30	BB-4901000X	81.70
.490	1.250	.006	.122	.240	.5000	3.0	BB-4901250	73.50	BB-4901250G	79.30	BB-4901250X	81.70
.490	1.500	.006	.122	.240	.5000	3.0	BB-4901500	73.50	BB-4901500G	79.30	BB-4901500X	81.70
.490	2.000	.006	.122	.240	.5000	4.0	BB-4902000	80.60	BB-4902000G	87.60	BB-4902000X	90.90
.490	2.500	.006	.122	.240	.5000	4.0	BB-4902500	80.60	BB-4902500G	87.60	BB-4902500X	90.90
.490	2.600	.006	.122	.240	.5000	4.0			BB-4902600G	87.60		
.490	2.750	.006	.122	.240	.5000	4.0	BB-4902750	80.60	BB-4902750G	87.60	BB-4902750X	90.90
.490	3.000	.006	.122	.240	.5000	6.0	BB-4903000	101.15	BB-4903000G	110.35	BB-4903000X	115.15
.490	3.500	.006	.122	.240	.5000	6.0	BB-4903500	101.15	BB-4903500G	110.35	BB-4903500X	115.15
.490	4.000	.006	.122	.240	.5000	6.0	BB-4904000	101.15			BB-4904000X	115.15
.490	4.500	.006	.122	.240	.5000	6.0	BB-4904500	101.15	BB-4904500G	110.35	BB-4904500X	115.15

Standard – Boring Tools



See pg 272 for tool set options

**BBL**

**Standard – Boring Tools**

**Left Hand**

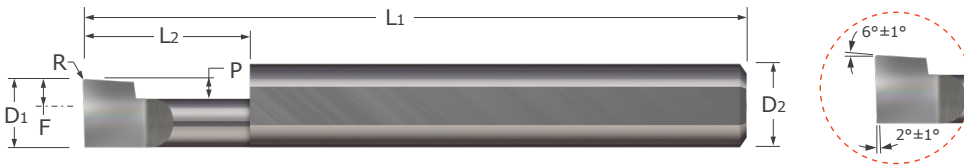

- Designed for left hand facing and boring applications
- Polished split face for improved edge retention and chip evacuation while reducing galling
- Split geometry makes the tool as rigid as possible
- Corner radius profile
- Lockdown flat automatically locates tool on center
- Coating options provide added lubricity and increased wear resistance in difficult to machine materials
- Solid carbide ■ CNC ground in the USA

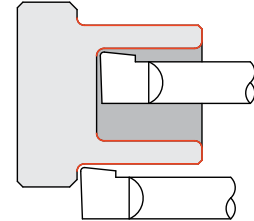

Minimum Bore Dia.	Maximum Bore Depth	Radius	Projection	Centerline Offset	Shank Dia.	OAL	Uncoated		TiN Coated		AlTiN Coated	
							Tool #	Price	Tool #	Price	Tool #	Price
D1	L2	R	P	F	D2 (h6)	L1						
	$^{+.050"}_{-.000"}\text{"}$	$^{+.003"}_{-.000"}\text{"}$										
.050	.150	.003	.012	-.013	.1250	1.5	BBL-050150	25.10	BBL-050150G	27.00	BBL-050150X	27.60
.050	.200	.003	.012	-.013	.1250	1.5	BBL-050200	25.10				
.050	.400	.003	.012	-.013	.1250	1.5	BBL-050400	25.10			BBL-050400X	27.60
.060	.150	.003	.015	-.003	.1250	1.5	BBL-060150	25.10			BBL-060150X	27.60
.060	.200	.003	.015	-.003	.1250	1.5	BBL-060200	25.10			BBL-060200X	27.60
.060	.300	.003	.015	-.003	.1250	1.5	BBL-060300	25.10			BBL-060300X	27.60
.060	.400	.003	.015	-.003	.1250	1.5	BBL-060400	25.10				
.080	.150	.003	.020	.018	.1250	1.5			BBL-080150G	27.00		
.080	.200	.003	.020	.018	.1250	1.5	BBL-080200	25.10			BBL-080200X	27.60
.080	.300	.003	.020	.018	.1250	1.5	BBL-080300	25.10			BBL-080300X	27.60
.080	.400	.003	.020	.018	.1250	1.5	BBL-080400	25.10	BBL-080400G	27.00	BBL-080400X	27.60
.080	.500	.003	.020	.018	.1250	1.5	BBL-080500	25.10	BBL-080500G	27.00	BBL-080500X	27.60
.100	.150	.003	.025	.038	.1250	1.5	BBL-100150	25.10			BBL-100150X	27.60
.100	.300	.003	.025	.038	.1250	1.5	BBL-100300	25.10	BBL-100300G	27.00	BBL-100300X	27.60
.100	.500	.003	.025	.038	.1250	1.5	BBL-100500	25.10	BBL-100500G	27.00	BBL-100500X	27.60
.100	.600	.003	.025	.038	.1250	1.5	BBL-100600	25.10				
.100	.700	.003	.025	.038	.1250	1.5	BBL-100700	25.10			BBL-100700X	27.60
.110	.150	.003	.027	.048	.1250	1.5	BBL-110150	25.10			BBL-110150X	27.60
.110	.200	.003	.027	.048	.1250	1.5			BBL-110200G	27.00		
.110	.300	.003	.027	.048	.1250	1.5	BBL-110300	25.10			BBL-110300X	27.60
.110	.400	.003	.027	.048	.1250	1.5	BBL-110400	25.10			BBL-110400X	27.60
.110	.600	.003	.027	.048	.1250	1.5	BBL-110600	25.10			BBL-110600X	27.60
.110	.700	.003	.027	.048	.1250	1.5	BBL-110700	25.10			BBL-110700X	27.60

Continued on next page

# Standard – Boring Tools

BBL

Left Hand (cont.)

Continued from previous page

Minimum Bore Dia.	Maximum Bore Depth	Radius	Projection	Centerline Offset	Shank Dia.	OAL	Uncoated		TIN Coated		AlTiN Coated	
D1	L2 $^{+.050}_{-.000}$ "	R $^{+.002}_{-.000}$ "	P	F	D2 (h6)	L1	Tool #	Price	Tool #	Price	Tool #	Price
.120	.250	.006	.030	.026	.1875	2.0	BBL-120250	26.65			BBL-120250X	29.55
.120	.500	.006	.030	.026	.1875	2.0	BBL-120500	26.65			BBL-120500X	29.55
.120	.600	.006	.030	.026	.1875	2.0	BBL-120600	26.65			BBL-120600X	29.55
.120	.700	.006	.030	.026	.1875	2.0	BBL-120700	26.65			BBL-120700X	29.55
.140	.250	.006	.035	.046	.1875	2.0	BBL-140250	26.65	BBL-140250G	28.75	BBL-140250X	29.55
.140	.400	.006	.035	.046	.1875	2.0	BBL-140400	26.65	BBL-140400G	28.75	BBL-140400X	29.55
.140	.500	.006	.035	.046	.1875	2.0	BBL-140500	26.65			BBL-140500X	29.55
.140	.600	.006	.035	.046	.1875	2.0	BBL-140600	26.65	BBL-140600G	28.75	BBL-140600X	29.55
.140	.700	.006	.035	.046	.1875	2.0	BBL-140700	26.65			BBL-140700X	29.55
.140	.800	.006	.035	.066	.1875	2.0	BBL-140800	26.65			BBL-140800X	29.55
.160	.400	.006	.040	.066	.1875	2.0	BBL-160400	26.65				
.160	.500	.006	.040	.066	.1875	2.0	BBL-160500	26.65			BBL-160500X	29.55
.160	.600	.006	.040	.066	.1875	2.0	BBL-160600	26.65			BBL-160600X	29.55
.160	.750	.006	.040	.066	.1875	2.0	BBL-160750	26.65				
.160	.900	.006	.040	.066	.1875	2.0	BBL-160900	26.65	BBL-160900G	28.75	BBL-160900X	29.55
.160	1.000	.006	.040	.055	.1875	2.0	BBL-1601000	26.65			BBL-1601000X	29.55
.180	.350	.006	.045	.055	.2500	2.5	BBL-180350	28.80			BBL-180350X	33.70
.180	.500	.006	.045	.055	.2500	2.5	BBL-180500	28.80			BBL-180500X	33.70
.180	.600	.006	.045	.055	.2500	2.5	BBL-180600	28.80	BBL-180600G	32.10	BBL-180600X	33.70
.180	.750	.006	.045	.055	.2500	2.5	BBL-180750	28.80	BBL-180750G	32.10	BBL-180750X	33.70
.180	.900	.006	.045	.055	.2500	2.5	BBL-180900	28.80			BBL-180900X	33.70
.180	1.000	.006	.045	.055	.2500	2.5	BBL-1801000	28.80			BBL-1801000X	33.70
.180	1.100	.006	.045	.055	.2500	2.5	BBL-1801100	28.80			BBL-1801100X	33.70
.180	1.500	.006	.045	.075	.2500	2.5	BBL-1801500	28.80			BBL-1801500X	33.70
.200	.400	.006	.050	.075	.2500	2.5	BBL-200400	28.80	BBL-200400G	32.10	BBL-200400X	33.70
.200	.500	.006	.050	.075	.2500	2.5	BBL-200500	28.80			BBL-200500X	33.70
.200	.600	.006	.050	.075	.2500	2.5	BBL-200600	28.80	BBL-200600G	32.10	BBL-200600X	33.70
.200	.700	.006	.050	.075	.2500	2.5	BBL-200700	28.80			BBL-200700X	33.70
.200	.800	.006	.050	.075	.2500	2.5	BBL-200800	28.80	BBL-200800G	32.10	BBL-200800X	33.70
.200	1.000	.006	.050	.075	.2500	2.5	BBL-2001000	28.80			BBL-2001000X	33.70
.200	1.100	.006	.050	.075	.2500	2.5	BBL-2001100	28.80				
.200	1.200	.006	.050	.075	.2500	2.5	BBL-2001200	28.80			BBL-2001200X	33.70
.200	1.300	.006	.050	.074	.2500	2.5	BBL-2001300	28.80			BBL-2001300X	33.70
.230	.600	.006	.057	.074	.3125	2.5	BBL-230600	38.65	BBL-230600G	43.55	BBL-230600X	45.45
.230	.700	.006	.057	.074	.3125	2.5	BBL-230700	38.65			BBL-230700X	45.45
.230	.800	.006	.057	.074	.3125	2.5	BBL-230800	38.65			BBL-230800X	45.45
.230	.900	.006	.057	.074	.3125	2.5	BBL-230900	38.65			BBL-230900X	45.45
.230	1.000	.006	.057	.074	.3125	2.5	BBL-2301000	38.65			BBL-2301000X	45.45
.230	1.100	.006	.057	.074	.3125	2.5	BBL-2001100	28.80				
.230	1.200	.006	.057	.074	.3125	2.5	BBL-2301200	38.65			BBL-2301200X	45.45
.230	1.250	.006	.057	.074	.3125	2.5	BBL-2301250	38.65				
.230	1.500	.006	.057	.074	.3125	2.5	BBL-2301500	38.65			BBL-2301500X	45.45
.230	1.600	.006	.057	.074	.3125	2.5	BBL-2301600	38.65			BBL-2301600X	45.45

Continued on next page

Standard – Boring Tools



## BBL

Standard – Boring Tools  
Left Hand (cont.)

Continued from previous page

Minimum Bore Dia.	Maximum Bore Depth	Radius	Projection	Centerline Offset	Shank Dia.	OAL	Uncoated		TIN Coated		AlTiN Coated	
D1	L2 $\begin{smallmatrix} +.050'' \\ -.000'' \end{smallmatrix}$	R $\begin{smallmatrix} +.002'' \\ -.000'' \end{smallmatrix}$	P	F	D2 (h6)	L1	Tool #	Price	Tool #	Price	Tool #	Price
.290	.500	.006	.072	.134	.3125	2.5	BBL-290500	38.65			BBL-290500X	45.45
.290	.600	.006	.072	.134	.3125	2.5	BBL-290600	38.65			BBL-290600X	45.45
.290	.750	.006	.072	.134	.3125	2.5	BBL-290750	38.65			BBL-290750X	45.45
.290	.900	.006	.072	.134	.3125	2.5	BBL-290900	38.65				
.290	1.000	.006	.072	.134	.3125	2.5	BBL-2901000	38.65			BBL-2901000X	45.45
.290	1.100	.006	.072	.134	.3125	2.5	BBL-2901100	38.65			BBL-2901100X	45.45
.290	1.250	.006	.072	.134	.3125	2.5	BBL-2901250	38.65			BBL-2901250X	45.45
.290	1.350	.006	.072	.134	.3125	2.5	BBL-2901350	38.65				
.290	1.500	.006	.072	.134	.3125	2.5	BBL-2901500	38.65			BBL-2901500X	45.45
.290	1.600	.006	.072	.134	.3125	2.5	BBL-2901600	38.65				
.320	.600	.006	.080	.133	.3750	2.5	BBL-320600	52.75	BBL-320600G	57.65	BBL-320600X	59.55
.320	.750	.006	.080	.133	.3750	2.5	BBL-320750	52.75			BBL-320750X	59.55
.320	1.000	.006	.080	.133	.3750	2.5	BBL-3201000	52.75			BBL-3201000X	59.55
.320	1.500	.006	.080	.133	.3750	2.5	BBL-3201500	52.75			BBL-3201500X	59.55
.320	1.800	.006	.080	.133	.3750	2.5	BBL-3201800	52.75				
.320	2.000	.006	.080	.133	.3750	4.0	BBL-3202000	67.45			BBL-3202000X	75.85
.320	2.500	.006	.080	.133	.3750	4.0	BBL-3202500	67.45				
.320	3.000	.006	.080	.133	.3750	4.0	BBL-3203000	67.45			BBL-3203000X	75.85
.360	.750	.006	.090	.173	.3750	2.5	BBL-360750	52.75			BBL-360750X	59.55
.360	.900	.006	.090	.173	.3750	2.5	BBL-360900	52.75				
.360	1.000	.006	.090	.173	.3750	2.5	BBL-3601000	52.75			BBL-3601000X	59.55
.360	1.150	.006	.090	.173	.3750	2.5	BBL-3601150	52.75				
.360	1.250	.006	.090	.173	.3750	2.5	BBL-3601250	52.75			BBL-3601250X	59.55
.360	1.500	.006	.090	.173	.3750	2.5	BBL-3601500	52.75			BBL-3601500X	59.55
.360	1.600	.006	.090	.173	.3750	2.5	BBL-3601600	52.75				
.360	1.800	.006	.090	.173	.3750	2.5	BBL-3601800	52.75				
.360	2.500	.006	.090	.173	.3750	4.0	BBL-3602500	67.45				
.360	3.000	.006	.090	.173	.3750	4.0	BBL-3603000	67.45			BBL-3603000X	75.85
.490	1.500	.006	.122	.240	.5000	3.0	BBL-4901500	73.50			BBL-4901500X	81.70
.490	2.600	.006	.122	.240	.5000	4.0	BBL-4902600	80.60				
.490	2.750	.006	.122	.240	.5000	4.0	BBL-4902750	80.60				
.490	3.500	.006	.122	.240	.5000	6.0	BBL-4903500	101.15				
.490	4.000	.006	.122	.240	.5000	6.0	BBL-4904000	101.15				
.490	4.500	.006	.122	.240	.5000	6.0	BBL-4904500	101.15				

# Standard – Boring Tools

HBBC

## Helical Back Rake – Corner Radius

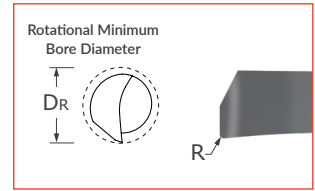
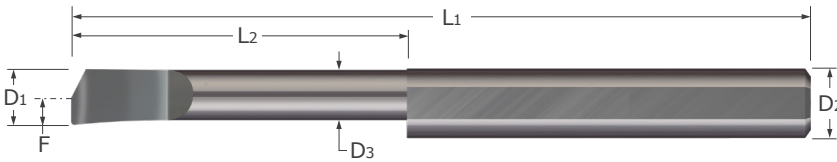

- Designed for boring applications in bores .0275" and larger
- Polished face for improved edge retention and chip evacuation while reducing galling
- Helical grind provides ideal top rake for better chip control and freer cutting
- Well suited for machining plastics
- On center neck design allows for static (D<sub>1</sub>) and live/rotating (D<sub>R</sub>) applications
- Lockdown flat automatically locates tool on center
- Corner radius profile
- Solid carbide ■ CNC ground in the USA

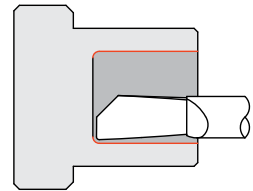

Standard – Boring Tools

Minimum Bore Diameter	Rotational Minimum Bore Diameter	Maximum Bore Depth	Radius	Neck Diameter	Centerline Offset	Shank Diameter	Overall Length	Uncoated	
D <sub>1</sub>	D <sub>R</sub>	L <sub>2</sub> <sup>+ .032"</sup> <sub>- .000"</sub>	R <sup>+ .001"</sup> <sub>- .001"</sub>	D <sub>3</sub> <sup>+ .000"</sup> <sub>- .002"</sub>	F	D <sub>2</sub> (h6)	L <sub>1</sub>	Tool #	Price
.0275	.030	.187	.004	.025	.015	.1250	1.5	HBBC-030187-004	33.40
.0275	.030	.250	.004	.025	.015	.1250	1.5	HBBC-030250-004	33.40
.0325	.035	.125	.004	.030	.018	.1250	1.5	HBBC-035125-004	26.10
.0325	.035	.187	.004	.030	.018	.1250	1.5	HBBC-035187-004	26.10
.0325	.035	.250	.004	.030	.018	.1250	1.5	HBBC-035250-004	26.10
.0375	.040	.187	.004	.035	.020	.1250	1.5	HBBC-040187-004	26.10
.0375	.040	.250	.004	.035	.020	.1250	1.5	HBBC-040250-004	26.10
.0375	.040	.312	.004	.035	.020	.1250	1.5	HBBC-040312-004	26.10
.0450	.050	.187	.004	.040	.025	.1250	1.5	HBBC-050187-004	26.10
.0450	.050	.312	.004	.040	.025	.1250	1.5	HBBC-050312-004	26.10
.0450	.050	.375	.004	.040	.025	.1250	1.5	HBBC-050375-004	26.10
.0550	.060	.250	.004	.050	.030	.1250	1.5	HBBC-060250-004	26.10
.0550	.060	.375	.004	.050	.030	.1250	1.5	HBBC-060375-004	26.10
.0550	.060	.500	.004	.050	.030	.1250	1.5	HBBC-060500-004	26.10
.0650	.070	.312	.004	.060	.035	.1250	1.5	HBBC-070312-004	26.10
.0650	.070	.437	.004	.060	.035	.1250	1.5	HBBC-070437-004	26.10
.0650	.070	.562	.004	.060	.035	.1250	1.5	HBBC-070562-004	26.10
.0750	.080	.375	.004	.070	.040	.1250	1.5	HBBC-080375-004	26.10
.0750	.080	.500	.004	.070	.040	.1250	1.5	HBBC-080500-004	26.10
.0750	.080	.625	.004	.070	.040	.1250	1.5	HBBC-080625-004	26.10
.0850	.090	.375	.004	.080	.045	.1250	1.5	HBBC-090375-004	26.10
.0850	.090	.500	.004	.080	.045	.1250	1.5	HBBC-090500-004	26.10
.0850	.090	.687	.004	.080	.045	.1250	1.5	HBBC-090687-004	26.10
.0950	.100	.437	.004	.090	.050	.1250	1.5	HBBC-100437-004	26.10
.0950	.100	.562	.004	.090	.050	.1250	1.5	HBBC-100562-004	26.10
.0950	.100	.750	.004	.090	.050	.1250	1.5	HBBC-100750-004	26.10

Continued on next page

## HBBC

## Standard – Boring Tools

### Helical Back Rake – Corner Radius (cont.)

Continued from previous page

Minimum Bore Diameter	Rotational Minimum Bore Diameter	Maximum Bore Depth	Radius	Neck Diameter	Centerline Offset	Shank Diameter	Overall Length	Uncoated	
								Tool #	Price
D <sub>1</sub>	D <sub>R</sub>	L <sub>2</sub> $\begin{smallmatrix} +.032'' \\ -.000'' \end{smallmatrix}$	R $\begin{smallmatrix} +.001'' \\ -.001'' \end{smallmatrix}$	D <sub>3</sub> $\begin{smallmatrix} +.000'' \\ -.002'' \end{smallmatrix}$	F	D <sub>2</sub> (h6)	L <sub>1</sub>		
.1100	.120	.500	.004	.100	.060	.1250	1.5	HBBC-120500-004	26.10
.1100	.120	.625	.004	.100	.060	.1250	1.5	HBBC-120625-004	26.10
.1100	.120	1.000	.004	.100	.060	.1250	1.5	HBBC-1201000-004	26.10
.1225	.135	.562	.004	.110	.068	.1875	2.0	HBBC-135562-004	28.10
.1225	.135	.750	.004	.110	.068	.1875	2.0	HBBC-135750-004	28.10
.1225	.135	1.000	.004	.110	.068	.1875	2.0	HBBC-1351000-004	28.10
.1400	.150	.625	.004	.130	.075	.1875	2.0	HBBC-150625-004	28.10
.1400	.150	1.000	.004	.130	.075	.1875	2.0	HBBC-1501000-004	28.10
.1400	.150	1.250	.004	.130	.075	.1875	2.0	HBBC-1501250-004	28.10
.1700	.180	1.000	.004	.160	.090	.1875	2.0	HBBC-1801000-004	28.10
.1700	.180	1.250	.004	.160	.090	.1875	2.0	HBBC-1801250-004	28.10
.1700	.180	1.500	.004	.160	.090	.1875	2.0	HBBC-1801500-004	28.10
.1975	.210	1.000	.004	.185	.105	.2500	2.5	HBBC-2101000-004	30.30
.1975	.210	1.250	.004	.185	.105	.2500	2.5	HBBC-2101250-004	30.30
.1975	.210	1.500	.004	.185	.105	.2500	2.5	HBBC-2101500-004	30.30
.2275	.240	1.000	.004	.215	.120	.2500	2.5	HBBC-2401000-004	30.30
.2275	.240	1.500	.004	.215	.120	.2500	2.5	HBBC-2401500-004	30.30
.2275	.240	1.750	.004	.215	.120	.2500	2.5	HBBC-2401750-004	30.30
.2750	.300	1.000	.004	.250	.150	.3125	2.5	HBBC-3001000-004	40.80
.2750	.300	1.500	.004	.250	.150	.3125	2.5	HBBC-3001500-004	40.80
.2750	.300	1.750	.004	.250	.150	.3125	2.5	HBBC-3001750-004	40.80
.3400	.360	1.000	.004	.320	.180	.3750	2.5	HBBC-3601000-004	56.10
.3400	.360	1.500	.004	.320	.180	.3750	2.5	HBBC-3601500-004	56.10
.3400	.360	2.000	.004	.320	.180	.3750	4.0	HBBC-3602000-004	71.70
.3400	.360	2.500	.004	.320	.180	.3750	4.0	HBBC-3602500-004	71.70

# Standard – Boring Tools

HBB / HBM

## Helical Back Rake

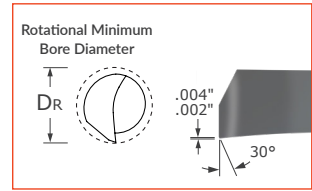
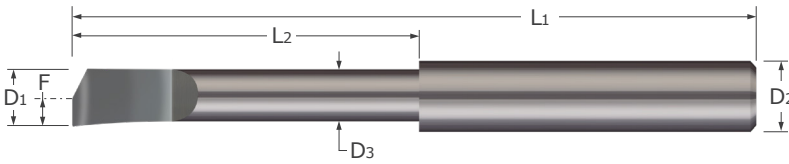

- Designed for boring applications in bores .018" and larger
- Polished face for improved edge retention and chip evacuation while reducing galling
- Helical grind provides ideal top rake for better chip control and freer cutting
- Uncoated variant ideal for plastics
- On center neck design allows for static (D<sub>1</sub>) and live/rotating (D<sub>R</sub>) applications
- Cylindrical shank (no set screw flat)
- AlTiN coated option provides added lubricity and increased wear resistance in difficult to machine materials
- Solid carbide ■ CNC ground in the USA

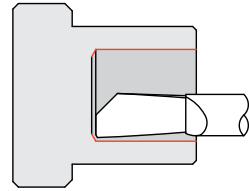

Standard – Boring Tools

Minimum Bore Diameter		Rotational Minimum Bore Diameter	Maximum Bore Depth	Neck Diameter	Centerline Offset	Shank Dia.	Overall Length	Uncoated		AlTiN Coated	
D <sub>1</sub>	decimal equiv.	D <sub>R</sub>	L <sub>2</sub> +.032" -.000" +.81 mm -.00 mm	D <sub>3</sub> +.000" -.002" +.00 mm -.05 mm	F	D <sub>2</sub> (h6)	L <sub>1</sub>	Tool #	Price	Tool #	Price
.0175	.0175	.020	.063	.015	.010	.1250	1.5	HBB-020062	31.90	HBB-020062X	34.40
0.45 mm	.0177	0.5 mm	2 mm	0.4 mm	0.25 mm	3 mm	38 mm	HBM-005002	29.00		
.0225	.0225	.025	.063	.020	.013	.1250	1.5	HBB-025062	31.90		
.0225	.0225	.025	.125	.020	.013	.1250	1.5	HBB-025125	31.90	HBB-025125X	34.40
0.65 mm	.0256	0.7 mm	3 mm	0.6 mm	0.35 mm	3 mm	38 mm	HBM-007003	29.00		
.0275	.0275	.030	.125	.025	.015	.1250	1.5	HBB-030125	31.90		
.0275	.0275	.030	.188	.025	.015	.1250	1.5	HBB-030187	31.90	HBB-030187X	34.40
0.75 mm	.0295	0.8 mm	4 mm	0.7 mm	0.40 mm	3 mm	38 mm	HBM-008004	29.00		
.0325	.0325	.035	.125	.030	.018	.1250	1.5	HBB-035125	24.60	HBB-035125X	27.10
.0325	.0325	.035	.188	.030	.018	.1250	1.5	HBB-035187	24.60	HBB-035187X	27.10
0.85 mm	.0335	0.9 mm	5 mm	0.8 mm	0.45 mm	3 mm	38 mm	HBM-009005	22.40		
0.90 mm	.0354	1.0 mm	6 mm	0.8 mm	0.50 mm	3 mm	38 mm	HBM-010006	22.40		
.0375	.0375	.040	.188	.035	.020	.1250	1.5	HBB-040187	24.60	HBB-040187X	27.10
.0375	.0375	.040	.250	.035	.020	.1250	1.5	HBB-040250	24.60	HBB-040250X	27.10
.0450	.0450	.050	.313	.040	.025	.1250	1.5	HBB-050312	24.60	HBB-050312X	27.10
1.35 mm	.0531	1.5 mm	9 mm	1.2 mm	0.75 mm	3 mm	38 mm	HBM-015009	22.40		
.0550	.0550	.060	.375	.050	.030	.1250	1.5	HBB-060375	24.60	HBB-060375X	27.10
1.63 mm	.0642	1.75 mm	10 mm	1.5 mm	0.88 mm	3 mm	38 mm	HBM-017510	22.40		
.0650	.0650	.070	.438	.060	.035	.1250	1.5	HBB-070437	24.60	HBB-070437X	27.10
.0750	.0750	.080	.500	.070	.040	.1250	1.5	HBB-080500	24.60	HBB-080500X	27.10
2.05 mm	.0807	2.26 mm	12 mm	1.9 mm	1.13 mm	3 mm	38 mm	HBM-022512	22.40		
.0850	.0850	.090	.500	.080	.045	.1250	1.5	HBB-090500	24.60	HBB-090500X	27.10
.0950	.0950	.100	.563	.090	.050	.1250	1.5	HBB-100562	24.60	HBB-100562X	27.10
2.58 mm	.1016	2.75 mm	14 mm	2.4 mm	1.38 mm	3 mm	38 mm	HBM-027514	22.40		
2.75 mm	.1083	3.0 mm	16 mm	2.5 mm	1.50 mm	4 mm	50 mm	HBM-030016	23.15		

Continued on next page

## HBB / HBM

Standard – Boring Tools  
Helical Back Rake (cont.)

Continued from previous page

Minimum Bore Diameter		Rotational Minimum Bore Diameter	Maximum Bore Depth	Neck Diameter	Centerline Offset	Shank Dia.	Overall Length	Uncoated		AlTiN Coated	
D <sub>1</sub>	decimal equiv.	D <sub>R</sub>	L <sub>2</sub> +.032" -.000" +.81 mm -.00 mm	D <sub>3</sub> +.000" -.002" +.00 mm -.05 mm	F	D <sub>2</sub> (h6)	L <sub>1</sub>	Tool #	Price	Tool #	Price
.1100	.1100	.120	.625	.100	.060	.1250	1.5	HBB-120625	24.60	HBB-120625X	27.10
.1100	.1100	.120	1.000	.100	.060	.1250	1.5	HBB-1201000	24.60	HBB-1201000X	27.10
.1225	.1225	.135	.750	.110	.068	.1875	2.0	HBB-135750	26.35	HBB-135750X	29.25
.1225	.1225	.135	1.000	.110	.068	.1875	2.0	HBB-1351000	26.35	HBB-1351000X	29.25
.1400	.1400	.150	1.000	.130	.075	.1875	2.0	HBB-1501000	26.35	HBB-1501000X	29.25
.1400	.1400	.150	1.250	.130	.075	.1875	2.0	HBB-1501250	26.35	HBB-1501250X	29.25
3.65 mm	.1437	4.0 mm	25 mm	3.3 mm	2.00 mm	6 mm	57 mm			HBM-040025X	35.65
4.15 mm	.1634	4.5 mm	30 mm	3.8 mm	2.25 mm	6 mm	57 mm	HBM-045030	25.90		
.1700	.1700	.180	1.000	.160	.090	.1875	2.0	HBB-1801000	26.35	HBB-1801000X	29.25
.1700	.1700	.180	1.250	.160	.090	.1875	2.0	HBB-1801250	26.35	HBB-1801250X	29.25
.1700	.1700	.180	1.500	.160	.090	.1875	2.0	HBB-1801500	26.35	HBB-1801500X	29.25
.1975	.1975	.210	1.000	.185	.105	.2500	2.5	HBB-2101000	28.55	HBB-2101000X	33.45
.1975	.1975	.210	1.250	.185	.105	.2500	2.5	HBB-2101250	28.55	HBB-2101250X	33.45
.1975	.1975	.210	1.500	.185	.105	.2500	2.5	HBB-2101500	28.55	HBB-2101500X	33.45
5.15 mm	.2028	5.5 mm	35 mm	4.8 mm	2.75 mm	6 mm	57 mm	HBM-055035	25.90		
.2275	.2275	.240	1.000	.215	.120	.2500	2.5	HBB-2401000	28.55	HBB-2401000X	33.45
.2275	.2275	.240	1.500	.215	.120	.2500	2.5	HBB-2401500	28.55	HBB-2401500X	33.45
.2275	.2275	.240	1.750	.215	.120	.2500	2.5	HBB-2401750	28.55	HBB-2401750X	33.45
.2750	.2750	.300	1.000	.250	.150	.3125	2.5	HBB-3001000	39.05	HBB-3001000X	45.85
.2750	.2750	.300	1.500	.250	.150	.3125	2.5	HBB-3001500	39.05	HBB-3001500X	45.85
.2750	.2750	.300	1.750	.250	.150	.3125	2.5	HBB-3001750	39.05	HBB-3001750X	45.85
.3400	.3400	.360	1.000	.320	.180	.3750	2.5	HBB-3601000	54.20		
.3400	.3400	.360	1.500	.320	.180	.3750	2.5	HBB-3601500	54.20	HBB-3601500X	61.00
.3400	.3400	.360	2.000	.320	.180	.3750	4.0	HBB-3602000	69.80	HBB-3602000X	75.60
.3400	.3400	.360	2.500	.320	.180	.3750	4.0	HBB-3602250	69.80		
.3400	.3400	.360	2.500	.320	.180	.3750	4.0	HBB-3602500	69.80	HBB-3602500X	75.60
.4600	.4600	.480	2.500	.440	.240	.5000	4.0	HBB-4802500	83.70		
.4600	.4600	.480	3.000	.440	.240	.5000	4.0	HBB-4803000	83.70		

# Standard – Boring Tools

PBT

## Top Rake Chipbreaker

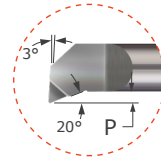
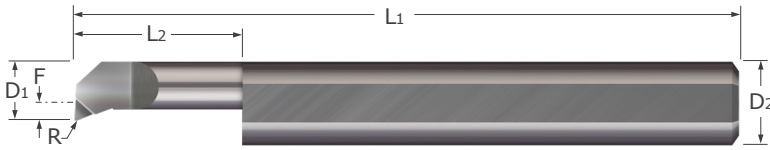

- Optimized for finishing operations
- Top rake geometry provides freer cutting
- Polished face for reducing galling
- Corner radius profile
- Lockdown flat automatically locates tool on center
- AlTiN coated option provides added lubricity and increased wear resistance in difficult to machine materials
- Solid carbide ■ CNC ground in the USA

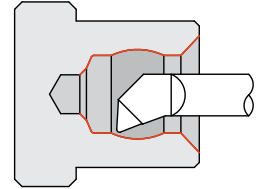

Standard – Boring Tools

Minimum Bore Diameter	Maximum Bore Depth	Radius	Projection	Centerline Offset	Shank Diameter	Overall Length	Uncoated		AlTiN Coated	
							Tool #	Price	Tool #	Price
$D_1$	$L_2$	$R$	$P$	$F$	$D_2$ (h6)	$L_1$				
	$^{+.030}_{-.000}$ "	$^{+.003}_{-.000}$ "								
.1200	.250	.004	.020	.026	.1875	2.0	PBT-120250	26.80	PBT-120250X	29.70
.1200	.500	.004	.020	.026	.1875	2.0	PBT-120500	26.80	PBT-120500X	29.70
.1200	.750	.004	.020	.026	.1875	2.0	PBT-120750	26.80	PBT-120750X	29.70
.1200	1.000	.004	.020	.026	.1875	2.0	PBT-1201000	26.80	PBT-1201000X	29.70
.1600	.500	.006	.025	.066	.1875	2.0	PBT-160500	26.80	PBT-160500X	29.70
.1600	.750	.006	.025	.066	.1875	2.0	PBT-160750	26.80	PBT-160750X	29.70
.1800	.500	.006	.030	.055	.2500	2.5	PBT-180500	34.30	PBT-180500X	39.20
.1800	1.000	.006	.030	.055	.2500	2.5	PBT-1801000	34.30	PBT-1801000X	39.20
.2000	.600	.006	.030	.075	.2500	2.5	PBT-200600	34.30	PBT-200600X	39.20
.2000	1.000	.006	.030	.075	.2500	2.5	PBT-2001000	34.30	PBT-2001000X	39.20
.2300	.750	.006	.040	.074	.3125	2.5	PBT-230750	42.40	PBT-230750X	49.20
.2300	1.600	.006	.040	.074	.3125	3.0	PBT-2301600	50.40	PBT-2301600X	57.20
.3000	1.000	.006	.050	.113	.3750	2.5	PBT-3001000	51.20	PBT-3001000X	58.00

## TBB

## Standard – Boring Tools

### Right Hand – Brazed – Sharp

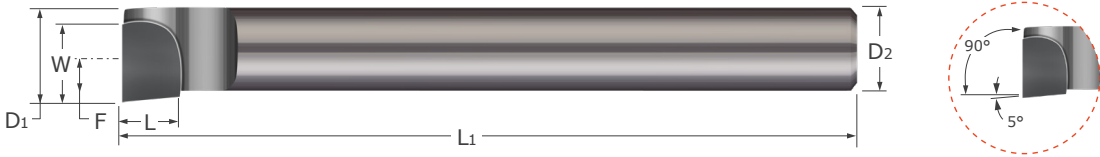

- Designed for right hand facing and boring applications in bores .320" and larger
- Long shank enables flexible reach options (preset at any length)
- Sharp corner profile
- Steel shank with brazed tip ■ CNC ground in the USA

Minimum Bore Diameter	Width	Length	Centerline Offset	Shank Diameter	Overall Length	Brazed Style	
						Tool #	Price
D1	W	L	F	D2 $^{+.000}$ / $_{-.003}$ "	L1		
.320	.250	.188	.195	.250	4.0	TBB-250	22.40
.413	.313	.250	.257	.313	5.0	TBB-312	23.40
.463	.313	.250	.276	.375	6.0	TBB-375	25.10
.625	.500	.250	.375	.500	7.0	TBB-500	31.20
.795	.500	.250	.483	.625	8.0	TBB-625	33.80
.935	.625	.250	.560	.750	9.0	TBB-750	34.90
1.233	.750	.375	.733	1.000	10.0	TBB-001	42.50

See pg 274 for tool set options

## Standard – Boring Tools

### TBBL

#### Left Hand – Brazed – Sharp

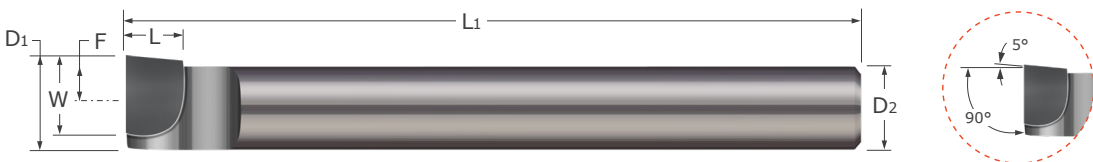

- Designed for left hand facing and boring applications in bores .320" and larger
- Long shank enables flexible reach options (preset at any length)
- Sharp corner profile
- Steel shank with brazed tip ■ CNC ground in the USA

Minimum Bore Diameter	Width	Length	Centerline Offset	Shank Diameter	Overall Length	Brazed Style	
						Tool #	Price
D1	W	L	F	D2 $^{+.000}$ / $_{-.003}$ "	L1		
.320	.250	.188	.195	.250	4.0	TBBL-250	21.80
.413	.313	.250	.257	.313	5.0	TBBL-312	22.40
.463	.313	.250	.276	.375	6.0	TBBL-375	24.00
.625	.500	.250	.375	.500	7.0	TBBL-500	31.10
.795	.500	.250	.483	.625	8.0	TBBL-625	33.20
.935	.625	.250	.560	.750	9.0	TBBL-750	34.10
1.233	.750	.375	.733	1.000	10.0	TBBL-001	42.50

See pg 274 for tool set options

## Standard – Boring Tools

TBBC

Right Hand – Brazed – Corner Radius

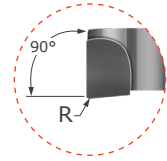
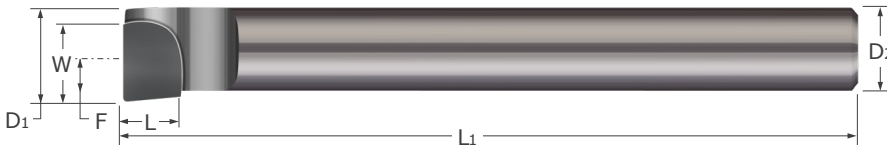

- Designed for right hand facing and boring applications in bores .320" and larger
- Long shank enables flexible reach options (preset at any length)
- Corner radius profile
- Steel shank with brazed tip ■ CNC ground in the USA

Minimum Bore Diameter	Radius	Width	Length	Centerline Offset	Shank Diameter	Overall Length	Brazed Style	
							Tool #	Price
D <sub>1</sub>	R <sup>+0.001"</sup> <sub>-.001"</sub>	W	L	F	D <sub>2</sub> <sup>+0.0000"</sup> <sub>-.0030"</sub>	L <sub>1</sub>		
.320	.008	.250	.188	.195	.2500	4.0	TBBC-250-008	24.10
.413	.008	.313	.250	.257	.3125	5.0	TBBC-312-008	25.10
.463	.008	.313	.250	.276	.3750	6.0	TBBC-375-008	26.80
.625	.008	.500	.250	.375	.5000	7.0	TBBC-500-008	32.90
.795	.008	.500	.250	.483	.6250	8.0	TBBC-625-008	35.50
.935	.008	.625	.250	.560	.7500	9.0	TBBC-750-008	36.60
1.233	.008	.750	.375	.733	1.0000	10.0	TBBC-001-008	42.50

Standard – Boring Tools

## Standard – Boring Tools

TBBCL

Left Hand – Brazed – Corner Radius

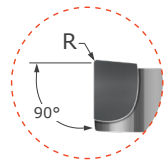
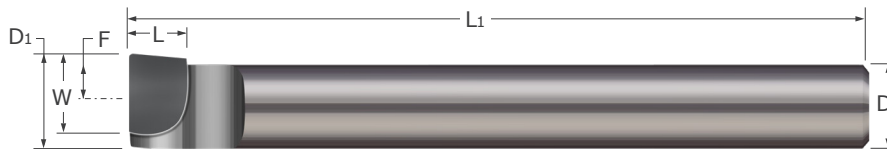

- Designed for left hand facing and boring applications in bores .320" and larger
- Long shank enables flexible reach options (preset at any length)
- Corner radius profile
- Steel shank with brazed tip ■ CNC ground in the USA

Minimum Bore Diameter	Radius	Width	Length	Centerline Offset	Shank Diameter	Overall Length	Brazed Style	
							Tool #	Price
D <sub>1</sub>	R <sup>+0.001"</sup> <sub>-.001"</sub>	W	L	F	D <sub>2</sub> <sup>+0.0000"</sup> <sub>-.0030"</sub>	L <sub>1</sub>		
.320	.008	.250	.188	.195	.2500	4.0	TBBCL-250-008	24.10
.413	.008	.313	.250	.257	.3125	5.0	TBBCL-312-008	25.10
.463	.008	.313	.250	.276	.3750	6.0	TBBCL-375-008	26.80
.625	.008	.500	.250	.375	.5000	7.0	TBBCL-500-008	32.90
.795	.008	.500	.250	.483	.6250	8.0	TBBCL-625-008	35.50
.935	.008	.625	.250	.560	.7500	9.0	TBBCL-750-008	36.60
1.233	.008	.750	.375	.733	1.0000	10.0	TBBCL-001-008	42.50



PR

Standard – Profiling Tools

Radial Profiling

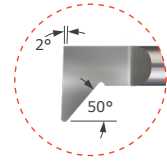
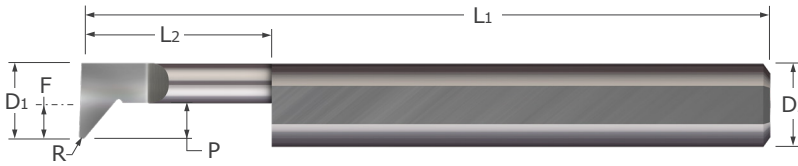

- Designed for radial profiling
- Excellent choice for fine finishing
- Can be used in thread relief applications
- Split geometry makes the tool as rigid as possible
- Corner radius profile
- Lockdown flat automatically locates tool on center
- AlTiN coated option provides added lubricity and increased wear resistance in difficult to machine materials
- Solid carbide ■ CNC ground in the USA

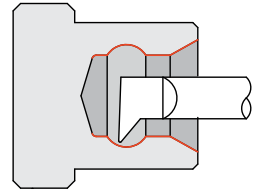

Minimum Bore Diameter	Maximum Bore Depth	Radius	Projection	Centerline Offset	Shank Diameter	Overall Length	Uncoated		AlTiN Coated	
							Tool #	Price	Tool #	Price
D1	L2 <sup>+0.050"</sup> <sub>-0.000"</sub>	R <sup>+0.002"</sup> <sub>-0.000"</sub>	P	F	D2 (h6)	L1	Tool #	Price	Tool #	Price
.0700	.200	.005	.025	.008	.1250	1.5	PR-070200	25.80	PR-070200X	28.30
.0700	.500	.005	.025	.008	.1250	1.5	PR-070500	25.80	PR-070500X	28.30
.1100	.250	.005	.040	.048	.1250	1.5	PR-110250	25.80	PR-110250X	28.30
.1200	.250	.008	.050	.026	.1875	2.0	PR-120250	26.85	PR-120250X	29.75
.1200	.500	.008	.050	.026	.1875	2.0	PR-120500	26.85	PR-120500X	29.75
.1600	.500	.008	.050	.066	.1875	2.0	PR-160500	26.85	PR-160500X	29.75
.1800	.500	.008	.080	.055	.2500	2.5	PR-180500	34.35	PR-180500X	39.25
.1800	.750	.008	.080	.055	.2500	2.5	PR-180750	34.35	PR-180750X	39.25
.2300	.750	.008	.080	.074	.3125	2.5	PR-230750	42.40	PR-230750X	49.20
.2300	1.000	.008	.080	.074	.3125	2.5	PR-2301000	42.40	PR-2301000X	49.20
.3000	1.000	.008	.110	.144	.3125	2.5	PR-3001000	42.40	PR-3001000X	49.20
.3000	1.250	.008	.110	.144	.3125	2.5	PR-3001250	42.40	PR-3001250X	49.20
.3600	1.000	.008	.130	.173	.3750	2.5	PR-3601000	54.95	PR-3601000X	61.75
.3600	1.250	.008	.130	.173	.3750	2.5	PR-3601250	54.95	PR-3601250X	61.75

Standard – Profiling Tools

# Standard – Profiling Tools

PF

## Axial Profiling

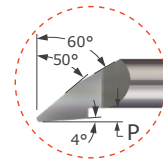
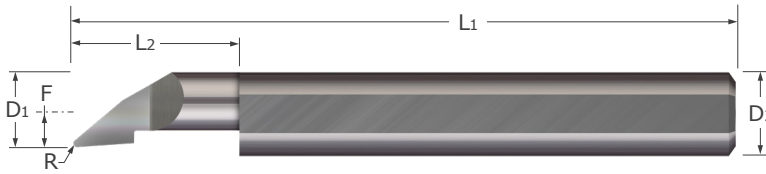

- Designed for both radial and axial profiling
- Unique design maximizes tool versatility and part feature creation
- Polished split face for improved edge retention and chip evacuation while reducing galling
- Split geometry makes the tool as rigid as possible
- Coolant fed enabled shank design
- Corner radius profile
- Lockdown flat automatically locates tool on center
- AlTiN coated option provides added lubricity and increased wear resistance in difficult to machine materials
- Solid carbide ■ CNC ground in the USA

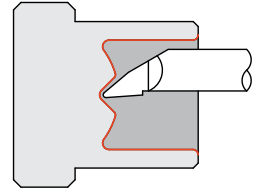

Standard – Profiling Tools

Minimum Bore Diameter	Maximum Bore Depth	Radius	Projection	Centerline Offset	Shank Diameter	Overall Length	Uncoated		AlTiN Coated		
D <sub>1</sub>	L <sub>2</sub> <sup>+0.030"</sup> <sub>-.000"</sub>	R <sup>+0.002"</sup> <sub>-.000"</sub>	P	F	D <sub>2</sub> (h6)	L <sub>1</sub>	Tool #	Price	Tool #	Price	
.0700	.200	.005	.010	.007	.1250	1.5	PF-070200	25.80	PF-070200X	28.30	NEW
.0700	.400	.005	.010	.007	.1250	1.5	PF-070400	25.80	PF-070400X	28.30	NEW
.0700	.500	.005	.010	.007	.1250	1.5	PF-070500	25.80	PF-070500X	28.30	NEW
.1100	.250	.005	.015	.047	.1250	1.5	PF-110250	25.80	PF-110250X	28.30	NEW
.1100	.500	.005	.015	.047	.1250	1.5	PF-110500	25.80	PF-110500X	28.30	NEW
.1100	.750	.005	.015	.047	.1250	1.5	PF-110750	25.80	PF-110750X	28.30	NEW
.1200	.250	.008	.020	.026	.1875	2.0	PF-120250	26.85	PF-120250X	29.75	NEW
.1200	.500	.008	.020	.026	.1875	2.0	PF-120500	26.85	PF-120500X	29.75	NEW
.1200	.750	.008	.020	.026	.1875	2.0	PF-120750	26.85	PF-120750X	29.75	NEW
.1600	.500	.008	.030	.066	.1875	2.0	PF-160500	26.85	PF-160500X	29.75	NEW
.1600	.750	.008	.030	.066	.1875	2.0	PF-160750	26.85	PF-160750X	29.75	NEW
.1800	.500	.008	.030	.055	.2500	2.5	PF-180500	34.35	PF-180500X	39.25	NEW
.1800	.750	.008	.030	.055	.2500	2.5	PF-180750	34.35	PF-180750X	39.25	NEW
.1800	1.000	.008	.030	.055	.2500	2.5	PF-1801000	34.35	PF-1801000X	39.25	NEW
.2000	.600	.008	.030	.075	.2500	2.5	PF-200600	34.35	PF-200600X	39.25	NEW
.2000	1.000	.008	.030	.075	.2500	2.5	PF-2001000	34.35	PF-2001000X	39.25	NEW
.2300	.750	.008	.030	.073	.3125	2.5	PF-230750	42.40	PF-230750X	49.20	NEW
.2300	1.000	.008	.030	.073	.3125	2.5	PF-2301000	42.40	PF-2301000X	49.20	NEW
.2300	1.250	.008	.030	.073	.3125	2.5	PF-2301250	42.40	PF-2301250X	49.20	NEW
.3000	1.000	.008	.030	.143	.3125	2.5	PF-3001000	42.40	PF-3001000X	49.20	NEW
.3600	1.000	.008	.030	.172	.3750	2.5	PF-3601000	54.95	PF-3601000X	61.75	NEW

## MRR

## Standard – Grooving Tools

### Retaining Ring – Square – Right Hand – Miniature

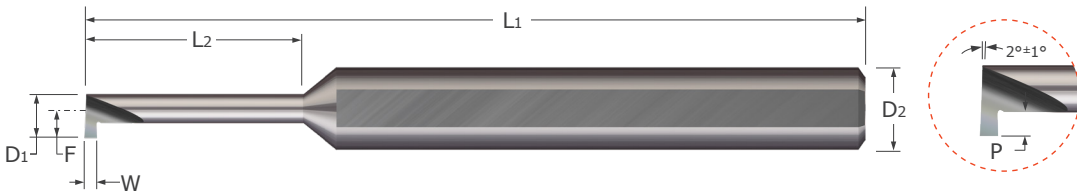

- Designed for generating retaining ring grooves in bores .060" and larger
- Polished face for improved edge retention and chip evacuation while reducing galling
- On-center neck design
- Coolant fed enabled shank design
- Sharp corner profile
- Lockdown flat automatically locates tool on center
- AlTiN coated option provides added lubricity and increased wear resistance in difficult to machine materials
- Solid carbide ■ CNC ground in the USA

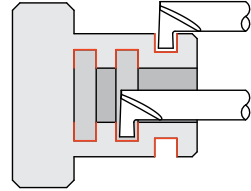

	Width	Minimum Bore Diameter	Maximum Bore Depth	Projection	Centerline Offset	Shank Diameter	Overall Length	Uncoated		AlTiN Coated	
								Tool #	Price	Tool #	Price
	$W \begin{matrix} +.001" \\ -.000" \end{matrix}$	D1	$L2 \begin{matrix} +.030" \\ -.000" \end{matrix}$	P	F	D2 (h6)	L1				
NEW	.015	.0600	.150	.020	.040	.1250	1.5	MRR-015-150-060	29.80	MRR-015-150-060X	32.30
NEW	.015	.0600	.250	.020	.040	.1250	1.5	MRR-015-250-060	29.80	MRR-015-250-060X	32.30
NEW	.020	.0600	.150	.020	.040	.1250	1.5	MRR-020-150-060	29.80	MRR-020-150-060X	32.30
NEW	.020	.0600	.250	.020	.040	.1250	1.5	MRR-020-250-060	29.80	MRR-020-250-060X	32.30
NEW	.020	.0700	.100	.020	.045	.1250	1.5	MRR-020-100-070	29.80	MRR-020-100-070X	32.30
NEW	.020	.0700	.150	.020	.045	.1250	1.5	MRR-020-150-070	29.80	MRR-020-150-070X	32.30
NEW	.020	.0800	.150	.025	.053	.1250	1.5	MRR-020-150-080	29.80	MRR-020-150-080X	32.30
NEW	.020	.0800	.250	.025	.053	.1250	1.5	MRR-020-250-080	29.80	MRR-020-250-080X	32.30
NEW	.020	.0900	.150	.025	.058	.1250	1.5	MRR-020-150-090	29.80	MRR-020-150-090X	32.30
NEW	.020	.0900	.250	.025	.058	.1250	1.5	MRR-020-250-090	29.80	MRR-020-250-090X	32.30
NEW	.020	.1000	.150	.030	.065	.1875	2.0	MRR-020-150-100	31.50	MRR-020-150-100X	34.40
NEW	.020	.1000	.250	.030	.065	.1875	2.0	MRR-020-250-100	31.50	MRR-020-250-100X	34.40
NEW	.020	.1200	.150	.040	.080	.1875	2.0	MRR-020-150-120	31.50	MRR-020-150-120X	34.40
NEW	.020	.1200	.250	.040	.080	.1875	2.0	MRR-020-250-120	31.50	MRR-020-250-120X	34.40
NEW	.030	.0700	.100	.020	.045	.1250	1.5	MRR-030-100-070	29.80	MRR-030-100-070X	32.30
NEW	.030	.0700	.150	.020	.045	.1250	1.5	MRR-030-150-070	29.80	MRR-030-150-070X	32.30
NEW	.030	.0800	.150	.025	.053	.1250	1.5	MRR-030-150-080	29.80	MRR-030-150-080X	32.30
NEW	.030	.0800	.250	.025	.053	.1250	1.5	MRR-030-250-080	29.80	MRR-030-250-080X	32.30
NEW	.030	.0900	.150	.025	.058	.1250	1.5	MRR-030-150-090	29.80	MRR-030-150-090X	32.30
NEW	.030	.0900	.250	.025	.058	.1250	1.5	MRR-030-250-090	29.80	MRR-030-250-090X	32.30
NEW	.030	.1000	.150	.030	.065	.1875	2.0	MRR-030-150-100	31.50	MRR-030-150-100X	34.40
NEW	.030	.1000	.250	.030	.065	.1875	2.0	MRR-030-250-100	31.50	MRR-030-250-100X	34.40
NEW	.030	.1200	.150	.040	.080	.1875	2.0	MRR-030-150-120	31.50	MRR-030-150-120X	34.40
NEW	.030	.1200	.250	.040	.080	.1875	2.0	MRR-030-250-120	31.50	MRR-030-250-120X	34.40

# Standard – Grooving Tools

## Retaining Ring – Square – Right Hand

RR / RRM

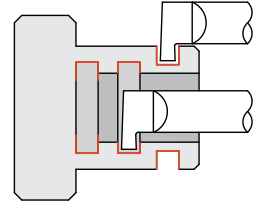
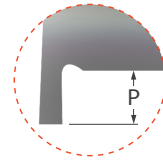
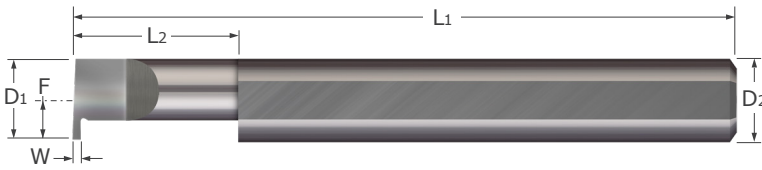

- Designed for generating retaining ring grooves
- Polished split face for improved edge retention and chip evacuation while reducing galling
- Sharp corner profile
- Lockdown flat automatically locates tool on center
- Coating options provide added lubricity and increased wear resistance in difficult to machine materials
- Solid carbide ■ CNC ground in the USA

Width	Minimum Bore Diameter	Maximum Bore Depth	Proj.	Ctrline Offset	Shank Dia.	OAL	Uncoated		TIN Coated		AITIN Coated	
							Tool #	Price	Tool #	Price	Tool #	Price
W +.001" +.025mm -.000" -.000mm	D1	L2	P	F	D2 (h6)	L1						
0.3 mm .0118	3 mm	10 mm	0.60 mm	1.5 mm	4 mm	50 mm	RRM-030-10	28.35			RRM-030-10X	31.25
0.3 mm .0118	3 mm	15 mm	0.60 mm	1.5 mm	4 mm	50 mm	RRM-030-15	28.35			RRM-030-15X	31.25
0.4 mm .0157	4 mm	10 mm	0.80 mm	2 mm	4 mm	50 mm	RRM-040-10	28.35			RRM-040-10X	31.25
0.4 mm .0157	4 mm	15 mm	0.80 mm	2 mm	4 mm	50 mm	RRM-040-15	28.35	RRM-040-15G 30.45		RRM-040-15X	31.25
0.4 mm .0157	4 mm	20 mm	0.80 mm	2 mm	4 mm	50 mm	RRM-040-20	28.35	RRM-040-20G 30.45		RRM-040-20X	31.25
.017	.0170	.187	.250	.030	.093	.1875 2.0	RR-017-250-187	30.80			RR-017-250-187X	33.70
.017	.0170	.187	.375	.030	.093	.1875 2.0	RR-017-375-187	30.80			RR-017-375-187X	33.70
.017	.0170	.187	.500	.030	.093	.1875 2.0	RR-017-500-187	30.80			RR-017-500-187X	33.70
.017	.0170	.187	.625	.030	.093	.1875 2.0	RR-017-625-187	30.80			RR-017-625-187X	33.70
.017	.0170	.250	.250	.050	.125	.2500 2.5	RR-017-4	33.60			RR-017-4X	38.50
.017	.0170	.250	.375	.050	.125	.2500 2.5	RR-017-6	33.60			RR-017-6X	38.50
.017	.0170	.250	.500	.050	.125	.2500 2.5	RR-017-8	33.60			RR-017-8X	38.50
.017	.0170	.250	.625	.050	.125	.2500 2.5	RR-017-10	33.60			RR-017-10X	38.50
0.5 mm .0200	6 mm	10 mm	1.24 mm	3 mm	6 mm	57 mm	RRM-050-10	33.05	RRM-050-10G 36.35		RRM-050-10X	37.95
0.5 mm .0200	6 mm	20 mm	1.24 mm	3 mm	6 mm	57 mm	RRM-050-20	33.05			RRM-050-20X	37.95
0.5 mm .0200	6 mm	25 mm	1.24 mm	3 mm	6 mm	57 mm	RRM-050-25	33.05	RRM-050-25G 36.35		RRM-050-25X	37.95
.020	.0200	.120	.150	.030	.026	.1875 2.0	RR-020-150-120	30.80			RR-020-150-120X	33.70
.020	.0200	.120	.250	.030	.026	.1875 2.0	RR-020-250-120	30.80			RR-020-250-120X	33.70
.020	.0200	.140	.250	.030	.046	.1875 2.0	RR-020-250-140	30.80			RR-020-250-140X	33.70
.020	.0200	.140	.375	.030	.046	.1875 2.0	RR-020-375-140	30.80			RR-020-375-140X	33.70
.020	.0200	.160	.250	.030	.066	.1875 2.0	RR-020-250-160	30.80			RR-020-250-160X	33.70
.020	.0200	.160	.375	.030	.066	.1875 2.0	RR-020-375-160	30.80			RR-020-375-160X	33.70
.020	.0200	.187	.250	.030	.093	.1875 2.0	RR-020-250-187	30.80			RR-020-250-187X	33.70
.020	.0200	.187	.375	.030	.093	.1875 2.0	RR-020-375-187	30.80			RR-020-375-187X	33.70
.020	.0200	.187	.500	.030	.093	.1875 2.0	RR-020-500-187	30.80			RR-020-500-187X	33.70
.020	.0200	.187	.625	.030	.093	.1875 2.0	RR-020-625-187	30.80			RR-020-625-187X	33.70
.020	.0200	.250	.250	.050	.125	.2500 2.5	RR-020-250-250	33.60			RR-020-250-250X	38.50
.020	.0200	.250	.375	.050	.125	.2500 2.5	RR-020-375-250	33.60			RR-020-375-250X	38.50
.020	.0200	.250	.500	.050	.125	.2500 2.5	RR-020-500-250	33.60			RR-020-500-250X	38.50
.020	.0200	.250	.625	.050	.125	.2500 2.5	RR-020-625-250	33.60			RR-020-625-250X	38.50
.025	.0250	.250	.250	.050	.125	.2500 2.5	RR-025-4	33.60			RR-025-4X	38.50
.025	.0250	.250	.375	.050	.125	.2500 2.5	RR-025-6	33.60			RR-025-6X	38.50
.025	.0250	.250	.500	.050	.125	.2500 2.5	RR-025-8	33.60			RR-025-8X	38.50

Standard – Grooving Tools

Continued on next page

## RR / RRM

Standard – Grooving Tools  
Retaining Ring – Square – Right Hand (cont.)

Continued from previous page

Width	Minimum Bore Diameter	Maximum Bore Depth	Proj.	Ctrline Offset	Shank Dia.	OAL	Uncoated		TIN Coated		AITIN Coated			
							Tool #	Price	Tool #	Price	Tool #	Price		
W + .001" + .025mm - .000" - .000mm	D1	L2 +.050" -.000" +1.25mm -.00mm	P	F	D2 (h6)	L1	Tool #	Price	Tool #	Price	Tool #	Price		
.025	.0250	.250	.625	.050	.125	.2500	2.5	RR-025-10	33.60			RR-025-10X	38.50	
NEW .025	.0250	.250	.750	.050	.125	.2500	2.5	RR-025-750-250	33.60			RR-025-750-250X	38.50	
NEW .025	.0250	.250	1.000	.050	.125	.2500	2.5	RR-025-1000-250	33.60			RR-025-1000-250X	38.50	
	0.7 mm	.0280	6 mm	10 mm	1.24 mm	3 mm	6 mm	57 mm	RRM-070-10	33.05			RRM-070-10X	37.95
	0.7 mm	.0280	6 mm	15 mm	1.24 mm	3 mm	6 mm	57 mm	RRM-070-15	33.05				
	0.7 mm	.0280	6 mm	20 mm	1.24 mm	3 mm	6 mm	57 mm	RRM-070-20	33.05				
	0.7 mm	.0280	6 mm	25 mm	1.24 mm	3 mm	6 mm	57 mm	RRM-070-25	33.05	RRM-070-25G	36.35	RRM-070-25X	37.95
NEW .029	.0290	.250	.250	.050	.125	.2500	2.5	RR-029-250-250	33.60			RR-029-250-250X	38.50	
NEW .029	.0290	.250	.500	.050	.125	.2500	2.5	RR-029-500-250	33.60			RR-029-500-250X	38.50	
NEW .030	.0300	.120	.150	.030	.026	.1875	2.0	RR-030-150-120	30.80			RR-030-150-120X	33.70	
NEW .030	.0300	.120	.250	.030	.026	.1875	2.0	RR-030-250-120	30.80			RR-030-250-120X	33.70	
NEW .030	.0300	.140	.250	.030	.046	.1875	2.0	RR-030-250-140	30.80			RR-030-250-140X	33.70	
NEW .030	.0300	.140	.375	.030	.046	.1875	2.0	RR-030-375-140	30.80			RR-030-375-140X	33.70	
NEW .030	.0300	.160	.250	.030	.066	.1875	2.0	RR-030-250-160	30.80			RR-030-250-160X	33.70	
NEW .030	.0300	.160	.375	.030	.066	.1875	2.0	RR-030-375-160	30.80			RR-030-375-160X	33.70	
NEW .030	.0300	.187	.250	.030	.093	.1875	2.0	RR-030-250-187	30.80			RR-030-250-187X	33.70	
NEW .030	.0300	.187	.500	.030	.093	.1875	2.0	RR-030-500-187	30.80			RR-030-500-187X	33.70	
	.030	.0300	.250	.250	.050	.125	.2500	2.5	RR-030-4	33.60			RR-030-4X	38.50
	.030	.0300	.250	.375	.050	.125	.2500	2.5	RR-030-6	33.60			RR-030-6X	38.50
	.030	.0300	.250	.500	.050	.125	.2500	2.5	RR-030-8	33.60			RR-030-8X	38.50
	.030	.0300	.250	.625	.050	.125	.2500	2.5	RR-030-10	33.60			RR-030-10X	38.50
NEW .030	.0300	.250	.750	.050	.125	.2500	2.5	RR-030-750-250	33.60			RR-030-750-250X	38.50	
NEW .030	.0300	.250	1.000	.050	.125	.2500	2.5	RR-030-1000-250	33.60			RR-030-1000-250X	38.50	
NEW .030	.0300	.312	.500	.100	.156	.3125	2.5	RR-030-500-312	41.90			RR-030-500-312X	48.70	
NEW .030	.0300	.312	.750	.100	.156	.3125	2.5	RR-030-750-312	41.90			RR-030-750-312X	48.70	
NEW .031	.0310	.250	.250	.050	.125	.2500	2.5	RR-031-250-250	33.60			RR-031-250-250X	38.50	
NEW .031	.0310	.250	.500	.050	.125	.2500	2.5	RR-031-500-250	33.60			RR-031-500-250X	38.50	
	0.8 mm	.0310	6 mm	15 mm	1.24 mm	3 mm	6 mm	57 mm	RRM-080-15	33.05	RRM-080-15G	36.35	RRM-080-15X	37.95
	0.8 mm	.0310	6 mm	25 mm	1.24 mm	3 mm	6 mm	57 mm	RRM-080-25	33.05	RRM-080-25G	36.35	RRM-080-25X	37.95
	.033	.0330	.312	.250	.100	.156	.3125	2.5	RR-033-4	41.90			RR-033-4X	48.70
	.033	.0330	.312	.375	.100	.156	.3125	2.5	RR-033-6	41.90			RR-033-6X	48.70
	.033	.0330	.312	.500	.100	.156	.3125	2.5	RR-033-8	41.90			RR-033-8X	48.70
	.033	.0330	.312	.750	.100	.156	.3125	2.5	RR-033-12	41.90			RR-033-12X	48.70
NEW .033	.0330	.312	1.000	.100	.156	.3125	2.5	RR-033-1000-312	41.90			RR-033-1000-312X	48.70	
NEW .033	.0330	.312	1.250	.100	.156	.3125	2.5	RR-033-1250-312	41.90			RR-033-1250-312X	48.70	
	0.9 mm	.0350	8 mm	20 mm	2.50 mm	4 mm	8 mm	63 mm	RRM-090-20	39.80			RRM-090-20X	46.60
	0.9 mm	.0350	8 mm	30 mm	2.50 mm	4 mm	8 mm	63 mm	RRM-090-30	39.80			RRM-090-30X	46.60
NEW .038	.0380	.250	.250	.050	.125	.2500	2.5	RR-038-250-250	33.60			RR-038-250-250X	38.50	
NEW .038	.0380	.250	.500	.050	.125	.2500	2.5	RR-038-500-250	33.60			RR-038-500-250X	38.50	
	.038	.0380	.312	.250	.100	.156	.3125	2.5	RR-038-4	41.90			RR-038-4X	48.70
	.038	.0380	.312	.375	.100	.156	.3125	2.5	RR-038-6	41.90			RR-038-6X	48.70
	.038	.0380	.312	.500	.100	.156	.3125	2.5	RR-038-8	41.90			RR-038-8X	48.70
	.038	.0380	.312	.750	.100	.156	.3125	2.5	RR-038-12	41.90			RR-038-12X	48.70
NEW .038	.0380	.312	1.000	.100	.156	.3125	2.5	RR-038-1000-312	41.90			RR-038-1000-312X	48.70	
NEW .038	.0380	.312	1.250	.100	.156	.3125	2.5	RR-038-1250-312	41.90			RR-038-1250-312X	48.70	

Continued on next page

# Standard – Grooving Tools

## Retaining Ring – Square – Right Hand (cont.)

RR / RRM

Continued from previous page

Width		Minimum Bore Diameter	Maximum Bore Depth	Proj.	Ctrline Offset	Shank Dia.	OAL	Uncoated		TIN Coated		AITIN Coated		
W +.002" +.050mm -.000" -.000mm	decimal equiv.	D1	L2	P	F	D2 (h6)	L1	Tool #	Price	Tool #	Price	Tool #	Price	
														+ .050" / - .000"
.039	.0390	.187	.250	.030	.093	.1875	2.0	RR-039-250-187	30.80			RR-039-250-187X	33.70	NEW
.039	.0390	.187	.500	.030	.093	.1875	2.0	RR-039-500-187	30.80			RR-039-500-187X	33.70	NEW
.039	.0390	.250	.250	.050	.125	.2500	2.5	RR-039-250-250	33.60			RR-039-250-250X	38.50	NEW
.039	.0390	.250	.500	.050	.125	.2500	2.5	RR-039-500-250	33.60			RR-039-500-250X	38.50	NEW
.039	.0390	.375	.250	.100	.188	.3750	2.5	RR-039-4	54.60			RR-039-4X	61.40	
.039	.0390	.375	.375	.100	.188	.3750	2.5	RR-039-6	54.60			RR-039-6X	61.40	
.039	.0390	.375	.500	.100	.188	.3750	2.5	RR-039-8	54.60			RR-039-8X	61.40	
.039	.0390	.375	.750	.100	.188	.3750	2.5	RR-039-12	54.60			RR-039-12X	61.40	
.039	.0390	.375	1.000	.100	.188	.3750	2.5	RR-039-16	54.60			RR-039-16X	61.40	
.039	.0390	.375	1.250	.100	.188	.3750	2.5	RR-039-20	54.60			RR-039-20X	61.40	
.039	.0390	.375	1.500	.100	.187	.3750	2.5	RR-039-1500-375	54.60			RR-039-1500-375X	61.40	NEW
1 mm	.0390	8 mm	10 mm	2.50 mm	4 mm	8 mm	63 mm	RRM-100-10	39.80	RRM-100-10G	44.70	RRM-100-10X	46.60	
1 mm	.0390	8 mm	20 mm	2.50 mm	4 mm	8 mm	63 mm	RRM-100-20	39.80			RRM-100-20X	46.60	
1 mm	.0390	8 mm	40 mm	2.50 mm	4 mm	8 mm	63 mm	RRM-100-40	39.80			RRM-100-40X	46.60	
.040	.0400	.250	.250	.050	.125	.2500	2.5	RR-040-250-250	33.60			RR-040-250-250X	38.50	NEW
.040	.0400	.250	.500	.050	.125	.2500	2.5	RR-040-500-250	33.60			RR-040-500-250X	38.50	NEW
1.1 mm	.0430	8 mm	10 mm	2.50 mm	4 mm	8 mm	63 mm	RRM-110-10	39.80	RRM-110-10G	44.70	RRM-110-10X	46.60	
1.1 mm	.0430	8 mm	20 mm	2.50 mm	4 mm	8 mm	63 mm	RRM-110-20	39.80			RRM-110-20X	46.60	
1.1 mm	.0430	8 mm	40 mm	2.50 mm	4 mm	8 mm	63 mm	RRM-110-40	39.80			RRM-110-40X	46.60	
.046	.0460	.312	.500	.100	.156	.3125	2.5	RR-046-500-312	41.90			RR-046-500-312X	48.70	NEW
.046	.0460	.312	.750	.100	.156	.3125	2.5	RR-046-750-312	41.90			RR-046-750-312X	48.70	NEW
.046	.0460	.375	.250	.100	.188	.3750	2.5	RR-046-4	54.60			RR-046-4X	61.40	
.046	.0460	.375	.375	.100	.188	.3750	2.5	RR-046-6	54.60			RR-046-6X	61.40	
.046	.0460	.375	.500	.100	.188	.3750	2.5	RR-046-8	54.60			RR-046-8X	61.40	
.046	.0460	.375	.750	.100	.188	.3750	2.5	RR-046-12	54.60			RR-046-12X	61.40	
.046	.0460	.375	1.000	.100	.188	.3750	2.5	RR-046-16	54.60			RR-046-16X	61.40	
.046	.0460	.375	1.250	.100	.188	.3750	2.5	RR-046-20	54.60			RR-046-20X	61.40	
1.2 mm	.0470	10 mm	20 mm	2.74 mm	5 mm	10 mm	72 mm	RRM-120-20	55.95			RRM-120-20X	62.75	
1.2 mm	.0470	10 mm	30 mm	2.74 mm	5 mm	10 mm	72 mm	RRM-120-30	55.95					
1.2 mm	.0470	10 mm	40 mm	2.74 mm	5 mm	10 mm	72 mm	RRM-120-40	55.95	RRM-120-40G	60.95	RRM-120-40X	62.75	
1.3 mm	.0510	10 mm	10 mm	2.74 mm	5 mm	10 mm	72 mm	RRM-130-10	55.95					
1.3 mm	.0510	10 mm	30 mm	2.74 mm	5 mm	10 mm	72 mm	RRM-130-30	55.95					
1.3 mm	.0510	10 mm	40 mm	2.74 mm	5 mm	10 mm	72 mm	RRM-130-40	55.95					
.055	.0550	.250	.250	.050	.125	.2500	2.5	RR-055-250-250	33.60			RR-055-250-250X	38.50	NEW
.055	.0550	.250	.500	.050	.125	.2500	2.5	RR-055-500-250	33.60			RR-055-500-250X	38.50	NEW
.055	.0550	.375	.250	.100	.188	.3750	2.5	RR-055-4	54.60			RR-055-4X	61.40	
.055	.0550	.375	.375	.100	.188	.3750	2.5	RR-055-6	54.60			RR-055-6X	61.40	
.055	.0550	.375	.500	.100	.188	.3750	2.5	RR-055-8	54.60			RR-055-8X	61.40	
.055	.0550	.375	.750	.100	.188	.3750	2.5	RR-055-12	54.60			RR-055-12X	61.40	
.055	.0550	.375	1.000	.100	.188	.3750	2.5	RR-055-16	54.60			RR-055-16X	61.40	
.055	.0550	.375	1.250	.100	.188	.3750	2.5	RR-055-20	54.60			RR-055-20X	61.40	
.055	.0550	.375	1.500	.100	.187	.3750	2.5	RR-055-1500-375	54.60			RR-055-1500-375X	61.40	NEW
.056	.0560	.250	.250	.050	.125	.2500	2.5	RR-056-250-250	33.60			RR-056-250-250X	38.50	NEW
.056	.0560	.250	.500	.050	.125	.2500	2.5	RR-056-500-250	33.60			RR-056-500-250X	38.50	NEW

Continued on next page

Standard – Grooving Tools

## RR / RRM

Standard – Grooving Tools  
Retaining Ring – Square – Right Hand (cont.)

Continued from previous page

	Width		Minimum Bore Diameter	Maximum Bore Depth	Proj.	Ctrl line Offset	Shank Dia.	OAL	Uncoated		TiN Coated		AlTiN Coated	
	W +.002" +.050mm -.000" -.000mm	decimal equiv.	D1	L2 +.050" -.000" +.125mm -.00mm	P	F	D2 (h6)	L1	Tool #	Price	Tool #	Price	Tool #	Price
NEW	.059	.0590	.375	.500	.100	.187	.3750	2.5	RR-059-500-375	54.60			RR-059-500-375X	61.40
NEW	.059	.0590	.375	1.000	.100	.187	.3750	2.5	RR-059-1000-375	54.60			RR-059-1000-375X	61.40
NEW	.062	.0620	.187	.250	.030	.093	.1875	2.0	RR-062-250-187	30.80			RR-062-250-187X	33.70
NEW	.062	.0620	.187	.500	.030	.093	.1875	2.0	RR-062-500-187	30.80			RR-062-500-187X	33.70
NEW	.062	.0620	.250	.250	.050	.125	.2500	2.5	RR-062-250-250	33.60			RR-062-250-250X	38.50
NEW	.062	.0620	.250	.500	.050	.125	.2500	2.5	RR-062-500-250	33.60			RR-062-500-250X	38.50
NEW	.062	.0620	.250	.750	.050	.125	.2500	2.5	RR-062-750-250	33.60			RR-062-750-250X	38.50
NEW	.062	.0620	.312	.500	.100	.156	.3125	2.5	RR-062-500-312	41.90			RR-062-500-312X	48.70
NEW	.062	.0620	.312	.750	.100	.156	.3125	2.5	RR-062-750-312	41.90			RR-062-750-312X	48.70
NEW	.062	.0620	.312	1.000	.100	.156	.3125	2.5	RR-062-1000-312	41.90			RR-062-1000-312X	48.70
	.062	.0620	.375	.250	.100	.188	.3750	2.5	RR-062-4	54.60			RR-062-4X	61.40
	.062	.0620	.375	.375	.100	.188	.3750	2.5	RR-062-6	54.60			RR-062-6X	61.40
	.062	.0620	.375	.500	.100	.188	.3750	2.5	RR-062-8	54.60			RR-062-8X	61.40
	.062	.0620	.375	.750	.100	.188	.3750	2.5	RR-062-12	54.60			RR-062-12X	61.40
	.062	.0620	.375	1.000	.100	.188	.3750	2.5	RR-062-16	54.60			RR-062-16X	61.40
	.062	.0620	.375	1.250	.100	.188	.3750	2.5	RR-062-20	54.60			RR-062-20X	61.40
NEW	.062	.0620	.375	1.500	.100	.187	.3750	2.5	RR-062-1500-375	54.60			RR-062-1500-375X	61.40
	1.6 mm	.0630	10 mm	30 mm	2.74 mm	5 mm	10 mm	72 mm	RRM-160-30	55.95				
	1.6 mm	.0630	10 mm	40 mm	2.74 mm	5 mm	10 mm	72 mm	RRM-160-40	55.95				
	.069	.0690	.375	.375	.100	.188	.3750	2.5	RR-069-6	54.60			RR-069-6X	61.40
	.069	.0690	.375	.500	.100	.188	.3750	2.5	RR-069-8	54.60			RR-069-8X	61.40
	.069	.0690	.375	.750	.100	.188	.3750	2.5	RR-069-12	54.60			RR-069-12X	61.40
	.069	.0690	.375	1.000	.100	.188	.3750	2.5	RR-069-16	54.60			RR-069-16X	61.40
	.069	.0690	.375	1.250	.100	.188	.3750	2.5	RR-069-20	54.60			RR-069-20X	61.40
	1.8 mm	.0710	10 mm	10 mm	2.74 mm	5 mm	10 mm	72 mm	RRM-180-10	55.95	RRM-180-10G	60.95		
NEW	.079	.0790	.375	.500	.100	.187	.3750	2.5	RR-079-500-375	54.60			RR-079-500-375X	61.40
NEW	.079	.0790	.375	1.000	.100	.187	.3750	2.5	RR-079-1000-375	54.60			RR-079-1000-375X	61.40
	2 mm	.0790	10 mm	20 mm	2.74 mm	5 mm	10 mm	72 mm	RRM-200-20	55.95	RRM-200-20G	60.95	RRM-200-20X	62.75
	2 mm	.0790	10 mm	30 mm	2.74 mm	5 mm	10 mm	72 mm	RRM-200-30	55.95	RRM-200-30G	60.95	RRM-200-30X	62.75
NEW	.087	.0870	.250	.250	.050	.125	.2500	2.5	RR-087-250-250	33.60			RR-087-250-250X	38.50
NEW	.087	.0870	.250	.500	.050	.125	.2500	2.5	RR-087-500-250	33.60			RR-087-500-250X	38.50
NEW	.087	.0870	.250	.750	.050	.125	.2500	2.5	RR-087-750-250	33.60			RR-087-750-250X	38.50
NEW	.087	.0870	.312	.500	.100	.156	.3125	2.5	RR-087-500-312	41.90			RR-087-500-312X	48.70
NEW	.087	.0870	.312	.750	.100	.156	.3125	2.5	RR-087-750-312	41.90			RR-087-750-312X	48.70
	.087	.0870	.375	.250	.100	.188	.3750	2.5	RR-087-4	54.60			RR-087-4X	61.40
	.087	.0870	.375	.375	.100	.188	.3750	2.5	RR-087-6	54.60			RR-087-6X	61.40
	.087	.0870	.375	.500	.100	.188	.3750	2.5	RR-087-8	54.60			RR-087-8X	61.40
	.087	.0870	.375	.750	.100	.188	.3750	2.5	RR-087-12	54.60			RR-087-12X	61.40
	.087	.0870	.375	1.000	.100	.188	.3750	2.5	RR-087-16	54.60			RR-087-16X	61.40
	.087	.0870	.375	1.250	.100	.188	.3750	2.5	RR-087-20	54.60			RR-087-20X	61.40
NEW	.087	.0870	.375	1.500	.100	.187	.3750	2.5	RR-087-1500-375	54.60			RR-087-1500-375X	61.40

Continued on next page

# Standard – Grooving Tools

## Retaining Ring – Square – Right Hand (cont.)

RR / RRM

Continued from previous page

Width		Minimum Bore Diameter	Maximum Bore Depth	Proj.	Ctrline Offset	Shank Dia.	OAL	Uncoated		TiN Coated		AlTiN Coated		
W	decimal equiv.	D1	L2	P	F	D2 (h6)	L1	Tool #	Price	Tool #	Price	Tool #	Price	
+ .002" - .000"	+ .050mm - .000mm		+ .050" - .000" + 1.25mm - .00mm											
.093	.0930	.375	.750	.100	.187	.3750	2.5	RR-093-750-375	54.60			RR-093-750-375X	61.40	NEW
.093	.0930	.375	1.000	.100	.187	.3750	2.5	RR-093-1000-375	54.60			RR-093-1000-375X	61.40	NEW
.093	.0930	.375	1.250	.100	.187	.3750	2.5	RR-093-1250-375	54.60			RR-093-1250-375X	61.40	NEW
.093	.0930	.500	.500	.150	.250	.5000	3.0	RR-093-8	76.55			RR-093-8X	84.75	
.093	.0930	.500	.750	.150	.250	.5000	3.0	RR-093-12	76.55			RR-093-12X	84.75	
.093	.0930	.500	1.000	.150	.250	.5000	3.0	RR-093-16	76.55			RR-093-16X	84.75	
.093	.0930	.500	1.250	.150	.250	.5000	3.0	RR-093-20	76.55			RR-093-20X	84.75	
.093	.0930	.500	1.500	.150	.250	.5000	3.0	RR-093-24	76.55			RR-093-24X	84.75	
.093	.0930	.500	1.750	.150	.250	.5000	3.0	RR-093-1750-500	76.55			RR-093-1750-500X	84.75	NEW
3 mm	.1180	12 mm	20 mm	3.76 mm	6 mm	12 mm	83 mm	RRM-300-20	71.75			RRM-300-20X	82.05	
3 mm	.1180	12 mm	30 mm	3.76 mm	6 mm	12 mm	83 mm	RRM-300-30	71.75			RRM-300-30X	82.05	
3 mm	.1180	12 mm	40 mm	3.76 mm	6 mm	12 mm	83 mm	RRM-300-40	71.75	RRM-300-40G	78.75	RRM-300-40X	82.05	
.125	.1250	.375	.750	.100	.187	.3750	2.5	RR-125-750-375	54.60			RR-125-750-375X	61.40	NEW
.125	.1250	.375	1.000	.100	.187	.3750	2.5	RR-125-1000-375	54.60			RR-125-1000-375X	61.40	NEW
.125	.1250	.375	1.250	.100	.187	.3750	2.5	RR-125-1250-375	54.60			RR-125-1250-375X	61.40	NEW
.125	.1250	.500	.500	.150	.250	.5000	3.0	RR-125-8	76.55			RR-125-8X	84.75	
.125	.1250	.500	.750	.150	.250	.5000	3.0	RR-125-12	76.55			RR-125-12X	84.75	
.125	.1250	.500	1.000	.150	.250	.5000	3.0	RR-125-16	76.55			RR-125-16X	84.75	
.125	.1250	.500	1.250	.150	.250	.5000	3.0	RR-125-20	76.55			RR-125-20X	84.75	
.125	.1250	.500	1.500	.150	.250	.5000	3.0	RR-125-24	76.55			RR-125-24X	84.75	
.125	.1250	.500	1.750	.150	.250	.5000	3.0	RR-125-1750-500	76.55			RR-125-1750-500X	84.75	NEW
.156	.1560	.500	.750	.150	.250	.5000	3.0	RR-156-12	76.55			RR-156-12X	84.75	
.156	.1560	.500	1.000	.150	.250	.5000	3.0	RR-156-16	76.55			RR-156-16X	84.75	
.156	.1560	.500	1.250	.150	.250	.5000	3.0	RR-156-20	76.55			RR-156-20X	84.75	
.156	.1560	.500	1.500	.150	.250	.5000	3.0	RR-156-24	76.55			RR-156-24X	84.75	
4 mm	.1570	12 mm	20 mm	3.76 mm	6 mm	12 mm	83 mm	RRM-400-20	71.75					
4 mm	.1570	12 mm	30 mm	3.76 mm	6 mm	12 mm	83 mm	RRM-400-30	71.75					
4 mm	.1570	12 mm	50 mm	3.76 mm	6 mm	12 mm	83 mm	RRM-400-50	71.75	RRM-400-50G	78.75	RRM-400-50X	82.05	
.187	.1870	.500	.750	.150	.250	.5000	3.0	RR-187-12	76.55			RR-187-12X	84.75	
.187	.1870	.500	1.000	.150	.250	.5000	3.0	RR-187-16	76.55			RR-187-16X	84.75	
.187	.1870	.500	1.250	.150	.250	.5000	3.0	RR-187-20	76.55			RR-187-20X	84.75	
.187	.1870	.500	1.500	.150	.250	.5000	3.0	RR-187-24	76.55			RR-187-24X	84.75	
5 mm	.1970	12 mm	20 mm	3.76 mm	6 mm	12 mm	83 mm	RRM-500-20	71.75					
5 mm	.1970	12 mm	30 mm	3.76 mm	6 mm	12 mm	83 mm	RRM-500-30	71.75					
5 mm	.1970	12 mm	50 mm	3.76 mm	6 mm	12 mm	83 mm	RRM-500-50	71.75			RRM-500-50X	82.05	
6 mm	.2360	12 mm	20 mm	3.76 mm	6 mm	12 mm	83 mm	RRM-600-20	71.75					
6 mm	.2360	12 mm	50 mm	3.76 mm	6 mm	12 mm	83 mm	RRM-600-50	71.75			RRM-600-50X	82.05	
.250	.2500	.500	.750	.150	.250	.5000	3.0	RR-250-12	76.55			RR-250-12X	84.75	
.250	.2500	.500	1.000	.150	.250	.5000	3.0	RR-250-16	76.55			RR-250-16X	84.75	
.250	.2500	.500	1.250	.150	.250	.5000	3.0	RR-250-20	76.55			RR-250-20X	84.75	
.250	.2500	.500	1.500	.150	.250	.5000	3.0	RR-250-24	76.55			RR-250-24X	84.75	

Standard – Grooving Tools

See pg 272 for tool set options



RRL

Standard – Grooving Tools  
Retaining Ring – Square – Left Hand

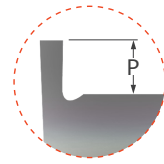
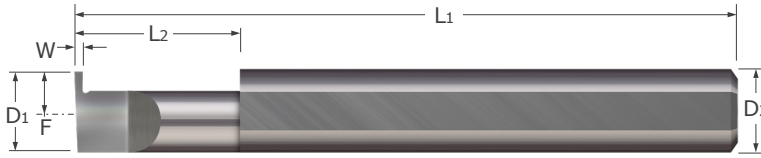

- Designed for generating retaining ring grooves in a left hand turning application
- Polished split face for improved edge retention and chip evacuation while reducing galling
- Sharp corner profile
- Lockdown flat automatically locates tool on center
- AlTiN coated option provides added lubricity and increased wear resistance in difficult to machine materials
- Solid carbide ■ CNC ground in the USA

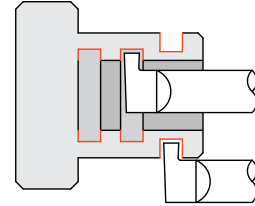

Width	Minimum Bore Diameter	Maximum Bore Depth	Projection	Centerline Offset	Shank Diameter	Overall Length	Uncoated		AlTiN Coated	
							Tool #	Price	Tool #	Price
W $+0.001"$ $-0.000"$	D1	L2 $+0.050"$ $-0.000"$	P	F	D2 (h6)	L1				
.017	.250	.250	.050	.125	.2500	2.5	RRL-017-4	33.60	RRL-017-4X	38.50
.017	.250	.500	.050	.125	.2500	2.5	RRL-017-8	33.60	RRL-017-8X	38.50
.025	.250	.250	.050	.125	.2500	2.5	RRL-025-4	33.60	RRL-025-4X	38.50
.025	.250	.500	.050	.125	.2500	2.5	RRL-025-8	33.60	RRL-025-8X	38.50
.030	.250	.250	.050	.125	.2500	2.5	RRL-030-4	33.60	RRL-030-4X	38.50
.030	.250	.375	.050	.125	.2500	2.5	RRL-030-6	33.60	RRL-030-6X	38.50
.030	.250	.500	.050	.125	.2500	2.5	RRL-030-8	33.60	RRL-030-8X	38.50
.030	.250	.625	.050	.125	.2500	2.5	RRL-030-10	33.60	RRL-030-10X	38.50
.033	.312	.250	.100	.155	.3125	2.5	RRL-033-4	41.90	RRL-033-4X	48.70
.033	.312	.375	.100	.155	.3125	2.5	RRL-033-6	41.90		
.033	.312	.750	.100	.155	.3125	2.5	RRL-033-12	41.90	RRL-033-12X	48.70
.038	.312	.250	.100	.155	.3125	2.5	RRL-038-4	41.90		
.038	.312	.375	.100	.155	.3125	2.5	RRL-038-6	41.90	RRL-038-6X	48.70
.038	.312	.500	.100	.155	.3125	2.5	RRL-038-8	41.90	RRL-038-8X	48.70
.038	.312	.750	.100	.155	.3125	2.5	RRL-038-12	41.90	RRL-038-12X	48.70

W $+0.002"$ $-0.000"$	D1	L2 $+0.050"$ $-0.000"$	P	F	D2 (h6)	L1	Tool #	Price	Tool #	Price
.039	.375	.250	.100	.187	.3750	2.5	RRL-039-4	54.60	RRL-039-4X	61.40
.039	.375	.500	.100	.187	.3750	2.5	RRL-039-8	54.60	RRL-039-8X	61.40
.039	.375	.750	.100	.187	.3750	2.5	RRL-039-12	54.60		
.046	.375	.250	.100	.187	.3750	2.5	RRL-046-4	54.60	RRL-046-4X	61.40
.046	.375	.375	.100	.187	.3750	2.5	RRL-046-6	54.60	RRL-046-6X	61.40
.046	.375	.750	.100	.187	.3750	2.5	RRL-046-12	54.60	RRL-046-12X	61.40
.046	.375	1.000	.100	.187	.3750	2.5	RRL-046-16	54.60	RRL-046-16X	61.40
.046	.375	1.250	.100	.187	.3750	2.5	RRL-046-20	54.60	RRL-046-20X	61.40
.055	.375	.250	.100	.187	.3750	2.5	RRL-055-4	54.60		
.055	.375	.500	.100	.187	.3750	2.5	RRL-055-8	54.60		
.055	.375	.750	.100	.187	.3750	2.5	RRL-055-12	54.60	RRL-055-12X	61.40
.055	.375	1.000	.100	.187	.3750	2.5	RRL-055-16	54.60	RRL-055-16X	61.40
.062	.375	.250	.100	.187	.3750	2.5	RRL-062-4	54.60		
.062	.375	.500	.100	.187	.3750	2.5	RRL-062-8	54.60	RRL-062-8X	61.40
.062	.375	.750	.100	.187	.3750	2.5	RRL-062-12	54.60	RRL-062-12X	61.40
.062	.375	1.250	.100	.187	.3750	2.5	RRL-062-20	54.60	RRL-062-20X	61.40

Continued on next page

# Standard – Grooving Tools

## Retaining Ring – Left Hand (cont.)

RRL

Continued from previous page

Width	Minimum Bore Diameter	Maximum Bore Depth	Projection	Centerline Offset	Shank Diameter	Overall Length	Uncoated		AITIN Coated	
							Tool #	Price	Tool #	Price
W $\begin{matrix} +.002" \\ -.000" \end{matrix}$	D <sub>1</sub>	L <sub>2</sub> $\begin{matrix} +.050" \\ -.000" \end{matrix}$	P	F	D <sub>2</sub> (h6)	L <sub>1</sub>	Tool #	Price	Tool #	Price
.069	.375	.250	.100	.187	.3750	2.5	RRL-069-4	54.60	RRL-069-4X	61.40
.069	.375	.500	.100	.187	.3750	2.5	RRL-069-8	54.60	RRL-069-8X	61.40
.069	.375	1.000	.100	.187	.3750	2.5	RRL-069-16	54.60	RRL-069-16X	61.40
.069	.375	1.250	.100	.187	.3750	2.5	RRL-069-20	54.60		
.087	.375	.375	.100	.187	.3750	2.5	RRL-087-6	54.60		
.087	.375	.500	.100	.187	.3750	2.5	RRL-087-8	54.60	RRL-087-8X	61.40
.087	.375	.750	.100	.187	.3750	2.5	RRL-087-12	54.60	RRL-087-12X	61.40
.087	.375	1.000	.100	.187	.3750	2.5	RRL-087-16	54.60	RRL-087-16X	61.40
.087	.375	1.250	.100	.187	.3750	2.5	RRL-087-20	54.60	RRL-087-20X	61.40
.093	.500	.750	.150	.250	.5000	3.0	RRL-093-12	76.55	RRL-093-12X	84.75
.093	.500	1.000	.150	.250	.5000	3.0	RRL-093-16	76.55	RRL-093-16X	84.75
.093	.500	1.500	.150	.250	.5000	3.0	RRL-093-24	76.55	RRL-093-24X	84.75
.125	.500	.500	.150	.250	.5000	3.0	RRL-125-8	76.55	RRL-125-8X	84.75
.125	.500	.750	.150	.250	.5000	3.0	RRL-125-12	76.55	RRL-125-12X	84.75
.125	.500	1.000	.150	.250	.5000	3.0	RRL-125-16	76.55	RRL-125-16X	84.75
.125	.500	1.500	.150	.250	.5000	3.0	RRL-125-24	76.55	RRL-125-24X	84.75
.156	.500	.500	.150	.250	.5000	3.0	RRL-156-8	76.55		
.187	.500	.500	.150	.250	.5000	3.0	RRL-187-8	76.55		
.187	.500	.750	.150	.250	.5000	3.0	RRL-187-12	76.55		
.187	.500	1.000	.150	.250	.5000	3.0	RRL-187-16	76.55		
.187	.500	1.250	.150	.250	.5000	3.0	RRL-187-20	76.55		
.250	.500	.500	.150	.250	.5000	3.0	RRL-250-8	76.55		
.250	.500	.750	.150	.250	.5000	3.0	RRL-250-12	76.55		
.250	.500	1.000	.150	.250	.5000	3.0	RRL-250-16	76.55		
.250	.500	1.250	.150	.250	.5000	3.0	RRL-250-20	76.55		

Standard – Grooving Tools

**RRC**

**Standard – Grooving Tools**  
Retaining Ring – Corner Radius – Right Hand

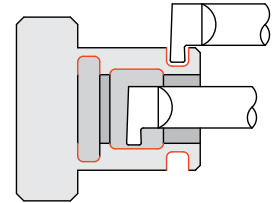
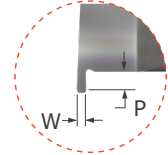
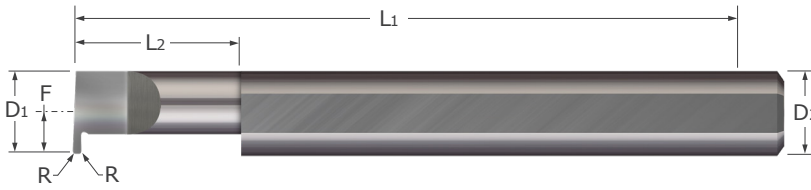

- Designed for generating corner radius retaining ring grooves in bores .180" and larger
- Corner radius designed for extended tool life, and finished groove profiling
- Polished split face for improved edge retention and chip evacuation while reducing galling
- Coolant fed enabled shank design
- Lockdown flat automatically locates tool on center
- AlTiN coated option provides added lubricity and increased wear resistance in difficult to machine materials
- Solid carbide ■ CNC ground in the USA

	Width	Minimum Bore Diameter	Maximum Bore Depth	Radius	Projection	Centerline Offset	Shank Diameter	Overall Length	Uncoated		AlTiN Coated	
	W <sup>+ .001"</sup> / <sub>-.000"</sub>	D1	L2 <sup>+ .050"</sup> / <sub>-.000"</sub>	R <sup>+ .001"</sup> / <sub>-.001"</sub>	P	F	D2 (h6)	L1	Tool #	Price	Tool #	Price
NEW	.017	.187	.250	.003	.030	.093	.1875	2.0	RRC3-017-250-187	35.80	RRC3-017-250-187X	38.70
NEW	.017	.187	.375	.003	.030	.093	.1875	2.0	RRC3-017-375-187	35.80	RRC3-017-375-187X	38.70
NEW	.017	.250	.250	.003	.050	.125	.2500	2.5	RRC3-017-250-250	38.60	RRC3-017-250-250X	43.50
NEW	.017	.250	.375	.003	.050	.125	.2500	2.5	RRC3-017-375-250	38.60	RRC3-017-375-250X	43.50
NEW	.020	.187	.250	.003	.030	.093	.1875	2.0	RRC3-020-250-187	35.80	RRC3-020-250-187X	38.70
NEW	.020	.187	.375	.003	.030	.093	.1875	2.0	RRC3-020-375-187	35.80	RRC3-020-375-187X	38.70
NEW	.020	.250	.250	.003	.050	.125	.2500	2.5	RRC3-020-250-250	38.60	RRC3-020-250-250X	43.50
NEW	.020	.250	.375	.003	.050	.125	.2500	2.5	RRC3-020-375-250	38.60	RRC3-020-375-250X	43.50
NEW	.025	.250	.250	.003	.050	.125	.2500	2.5	RRC3-025-250-250	38.60	RRC3-025-250-250X	43.50
NEW	.025	.250	.375	.003	.050	.125	.2500	2.5	RRC3-025-375-250	38.60	RRC3-025-375-250X	43.50
NEW	.030	.187	.250	.003	.030	.093	.1875	2.0	RRC3-030-250-187	35.80	RRC3-030-250-187X	38.70
NEW	.030	.187	.500	.003	.030	.093	.1875	2.0	RRC3-030-500-187	35.80	RRC3-030-500-187X	38.70
NEW	.030	.250	.250	.003	.050	.125	.2500	2.5	RRC3-030-250-250	38.60	RRC3-030-250-250X	43.50
NEW	.030	.250	.375	.003	.050	.125	.2500	2.5	RRC3-030-375-250	38.60	RRC3-030-375-250X	43.50
NEW	.030	.312	.500	.003	.100	.156	.3125	2.5	RRC3-030-500-312	48.15	RRC3-030-500-312X	54.95
NEW	.030	.312	.750	.003	.100	.156	.3125	2.5	RRC3-030-750-312	48.15	RRC3-030-750-312X	54.95
NEW	.033	.312	.500	.003	.100	.156	.3125	2.5	RRC3-033-500-312	48.15	RRC3-033-500-312X	54.95
NEW	.033	.312	.750	.003	.100	.156	.3125	2.5	RRC3-033-750-312	48.15	RRC3-033-750-312X	54.95
NEW	.038	.312	.500	.003	.100	.156	.3125	2.5	RRC3-038-500-312	48.15	RRC3-038-500-312X	54.95
NEW	.038	.312	.750	.003	.100	.156	.3125	2.5	RRC3-038-750-312	48.15	RRC3-038-750-312X	54.95
NEW	.039	.375	.500	.003	.100	.187	.3750	2.5	RRC3-039-500-375	61.00	RRC3-039-500-375X	67.80
NEW	.039	.375	.750	.003	.100	.187	.3750	2.5	RRC3-039-750-375	61.00	RRC3-039-750-375X	67.80
NEW	.039	.375	1.000	.003	.100	.187	.3750	2.5	RRC3-039-1000-375	61.00	RRC3-039-1000-375X	67.80
NEW	.062	.375	.500	.003	.100	.187	.3750	2.5	RRC3-062-500-375	61.00	RRC3-062-500-375X	67.80
NEW	.062	.375	.500	.006	.100	.187	.3750	2.5	RRC6-062-500-375	61.00	RRC6-062-500-375X	67.80
NEW	.062	.375	.750	.003	.100	.187	.3750	2.5	RRC3-062-750-375	61.00	RRC3-062-750-375X	67.80
NEW	.062	.375	.750	.006	.100	.187	.3750	2.5	RRC6-062-750-375	61.00	RRC6-062-750-375X	67.80
NEW	.062	.375	1.000	.003	.100	.187	.3750	2.5	RRC3-062-1000-375	61.00	RRC3-062-1000-375X	67.80
NEW	.062	.375	1.000	.006	.100	.187	.3750	2.5	RRC6-062-1000-375	61.00	RRC6-062-1000-375X	67.80

Continued on next page

## Standard – Grooving Tools

RRC

### Retaining Ring – Corner Radius – Right Hand (cont.)

Continued from previous page

Width	Minimum Bore Diameter	Maximum Bore Depth	Radius	Projection	Centerline Offset	Shank Diameter	Overall Length	Uncoated		AITIN Coated	
								Tool #	Price	Tool #	Price
W $\begin{matrix} +.002" \\ -.000" \end{matrix}$	D1	L2 $\begin{matrix} +.050" \\ -.000" \end{matrix}$	R $\begin{matrix} +.001" \\ -.001" \end{matrix}$	P	F	D2 (h6)	L1				
.087	.375	.500	.003	.100	.187	.3750	2.5	RRC3-087-500-375	61.00	RRC3-087-500-375X	67.80
.087	.375	.500	.006	.100	.187	.3750	2.5	RRC6-087-500-375	61.00	RRC6-087-500-375X	67.80
.087	.375	.750	.003	.100	.187	.3750	2.5	RRC3-087-750-375	61.00	RRC3-087-750-375X	67.80
.087	.375	.750	.006	.100	.187	.3750	2.5	RRC6-087-750-375	61.00	RRC6-087-750-375X	67.80
.087	.375	1.000	.003	.100	.187	.3750	2.5	RRC3-087-1000-375	61.00	RRC3-087-1000-375X	67.80
.087	.375	1.000	.006	.100	.187	.3750	2.5	RRC6-087-1000-375	61.00	RRC6-087-1000-375X	67.80
.093	.500	.750	.003	.150	.250	.5000	3.0	RRC3-093-750-500	83.85	RRC3-093-750-500X	92.05
.093	.500	.750	.006	.150	.250	.5000	3.0	RRC6-093-750-500	83.85	RRC6-093-750-500X	92.05
.093	.500	1.000	.003	.150	.250	.5000	3.0	RRC3-093-1000-500	83.85	RRC3-093-1000-500X	92.05
.093	.500	1.000	.006	.150	.250	.5000	3.0	RRC6-093-1000-500	83.85	RRC6-093-1000-500X	92.05
.125	.500	.750	.003	.150	.250	.5000	3.0	RRC3-125-750-500	83.85	RRC3-125-750-500X	92.05
.125	.500	.750	.006	.150	.250	.5000	3.0	RRC6-125-750-500	83.85	RRC6-125-750-500X	92.05
.125	.500	1.000	.003	.150	.250	.5000	3.0	RRC3-125-1000-500	83.85	RRC3-125-1000-500X	92.05
.125	.500	1.000	.006	.150	.250	.5000	3.0	RRC6-125-1000-500	83.85	RRC6-125-1000-500X	92.05

FR

Standard – Grooving Tools

Full Radius

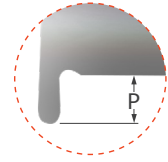
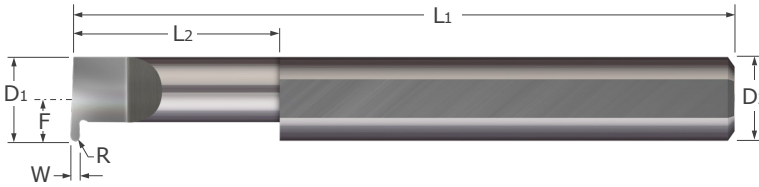

- Designed for generating full radius grooves
- Polished split face for improved edge retention and chip evacuation while reducing galling
- Full radius profile
- Lockdown flat automatically locates tool on center
- AlTiN coated option provides added lubricity and increased wear resistance in difficult to machine materials
- Solid carbide ■ CNC ground in the USA

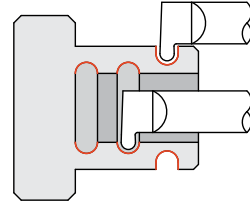

Width	Radius	Minimum Bore Diameter	Maximum Bore Depth	Projection	Centerline Offset	Shank Diameter	Overall Length	Uncoated		AlTiN Coated	
								Tool #	Price	Tool #	Price
W $\begin{smallmatrix} +.002" \\ -.000" \end{smallmatrix}$	R	D <sub>1</sub>	L <sub>2</sub> $\begin{smallmatrix} +.050" \\ -.000" \end{smallmatrix}$	P	F	D <sub>2</sub> (h6)	L <sub>1</sub>				
.017	.0085	.187	.250	.030	.093	.1875	2.0	FR-017-4-187	35.80	FR-017-4-187X	38.70
.017	.0085	.187	.375	.030	.093	.1875	2.0	FR-017-6-187	35.80	FR-017-6-187X	38.70
.017	.0085	.187	.500	.030	.093	.1875	2.0	FR-017-8-187	35.80	FR-017-8-187X	38.70
.017	.0085	.187	.625	.030	.093	.1875	2.0	FR-017-10-187	35.80	FR-017-10-187X	38.70
.017	.0085	.250	.250	.050	.125	.2500	2.5	FR-017-4	38.60	FR-017-4X	43.50
.017	.0085	.250	.375	.050	.125	.2500	2.5	FR-017-6	38.60	FR-017-6X	43.50
.017	.0085	.250	.500	.050	.125	.2500	2.5	FR-017-8	38.60	FR-017-8X	43.50
.017	.0085	.250	.625	.050	.125	.2500	2.5	FR-017-10	38.60	FR-017-10X	43.50
.020	.0100	.187	.250	.030	.093	.1875	2.0	FR-020-4-187	35.80	FR-020-4-187X	38.70
.020	.0100	.187	.375	.030	.093	.1875	2.0	FR-020-6-187	35.80	FR-020-6-187X	38.70
.020	.0100	.187	.500	.030	.093	.1875	2.0	FR-020-8-187	35.80	FR-020-8-187X	38.70
.020	.0100	.187	.625	.030	.093	.1875	2.0	FR-020-10-187	35.80	FR-020-10-187X	38.70
.025	.0125	.250	.250	.050	.125	.2500	2.5	FR-025-4	38.60	FR-025-4X	43.50
.025	.0125	.250	.375	.050	.125	.2500	2.5	FR-025-6	38.60	FR-025-6X	43.50
.025	.0125	.250	.500	.050	.125	.2500	2.5	FR-025-8	38.60	FR-025-8X	43.50
.025	.0125	.250	.625	.050	.125	.2500	2.5	FR-025-10	38.60	FR-025-10X	43.50
.030	.0150	.250	.250	.050	.125	.2500	2.5	FR-030-4	38.60	FR-030-4X	43.50
.030	.0150	.250	.375	.050	.125	.2500	2.5	FR-030-6	38.60	FR-030-6X	43.50
.030	.0150	.250	.500	.050	.125	.2500	2.5	FR-030-8	38.60	FR-030-8X	43.50
.030	.0150	.250	.625	.050	.125	.2500	2.5	FR-030-10	38.60	FR-030-10X	43.50
.033	.0165	.312	.250	.100	.155	.3125	2.5	FR-033-4	48.15	FR-033-4X	54.95
.033	.0165	.312	.375	.100	.155	.3125	2.5	FR-033-6	48.15	FR-033-6X	54.95
.033	.0165	.312	.500	.100	.155	.3125	2.5	FR-033-8	48.15	FR-033-8X	54.95
.033	.0165	.312	.625	.100	.155	.3125	2.5	FR-033-10	48.15	FR-033-10X	54.95
.038	.0190	.312	.250	.100	.155	.3125	2.5	FR-038-4	48.15	FR-038-4X	54.95
.038	.0190	.312	.375	.100	.155	.3125	2.5	FR-038-6	48.15	FR-038-6X	54.95
.038	.0190	.312	.500	.100	.155	.3125	2.5	FR-038-8	48.15	FR-038-8X	54.95
.038	.0190	.312	.625	.100	.155	.3125	2.5	FR-038-10	48.15	FR-038-10X	54.95
.039	.0195	.375	.250	.100	.187	.3750	2.5	FR-039-4	61.00	FR-039-4X	67.80
.039	.0195	.375	.375	.100	.187	.3750	2.5	FR-039-6	61.00	FR-039-6X	67.80
.039	.0195	.375	.500	.100	.187	.3750	2.5	FR-039-8	61.00	FR-039-8X	67.80
.039	.0195	.375	.750	.100	.187	.3750	2.5	FR-039-12	61.00	FR-039-12X	67.80
.039	.0195	.375	1.000	.100	.187	.3750	2.5	FR-039-16	61.00	FR-039-16X	67.80
.039	.0195	.375	1.250	.100	.187	.3750	2.5	FR-039-20	61.00	FR-039-20X	67.80

Continued on next page

# Standard – Grooving Tools

FR

## Full Radius (cont.)

Continued from previous page

Width	Radius	Minimum Bore Diameter	Maximum Bore Depth	Projection	Centerline Offset	Shank Diameter	Overall Length	Uncoated		AITIN Coated	
								Tool #	Price	Tool #	Price
W $\begin{matrix} +.002" \\ -.000" \end{matrix}$	R	D <sub>1</sub>	L <sub>2</sub> $\begin{matrix} +.050" \\ -.000" \end{matrix}$	P	F	D <sub>2</sub> (h6)	L <sub>1</sub>				
.046	.0230	.375	.250	.100	.187	.3750	2.5	FR-046-4	61.00	FR-046-4X	67.80
.046	.0230	.375	.375	.100	.187	.3750	2.5	FR-046-6	61.00	FR-046-6X	67.80
.046	.0230	.375	.500	.100	.187	.3750	2.5	FR-046-8	61.00	FR-046-8X	67.80
.046	.0230	.375	.750	.100	.187	.3750	2.5	FR-046-12	61.00	FR-046-12X	67.80
.046	.0230	.375	1.000	.100	.187	.3750	2.5	FR-046-16	61.00	FR-046-16X	67.80
.046	.0230	.375	1.250	.100	.187	.3750	2.5	FR-046-20	61.00	FR-046-20X	67.80
.055	.0275	.375	.250	.100	.187	.3750	2.5	FR-055-4	61.00	FR-055-4X	67.80
.055	.0275	.375	.375	.100	.187	.3750	2.5	FR-055-6	61.00	FR-055-6X	67.80
.055	.0275	.375	.500	.100	.187	.3750	2.5	FR-055-8	61.00	FR-055-8X	67.80
.055	.0275	.375	.750	.100	.187	.3750	2.5	FR-055-12	61.00	FR-055-12X	67.80
.055	.0275	.375	1.000	.100	.187	.3750	2.5	FR-055-16	61.00	FR-055-16X	67.80
.055	.0275	.375	1.250	.100	.187	.3750	2.5	FR-055-20	61.00	FR-055-20X	67.80
.062	.0310	.375	.250	.100	.187	.3750	2.5	FR-062-4	61.00	FR-062-4X	67.80
.062	.0310	.375	.375	.100	.187	.3750	2.5	FR-062-6	61.00	FR-062-6X	67.80
.062	.0310	.375	.500	.100	.187	.3750	2.5	FR-062-8	61.00	FR-062-8X	67.80
.062	.0310	.375	.750	.100	.187	.3750	2.5	FR-062-12	61.00	FR-062-12X	67.80
.062	.0310	.375	1.000	.100	.187	.3750	2.5	FR-062-16	61.00	FR-062-16X	67.80
.062	.0310	.375	1.250	.100	.187	.3750	2.5	FR-062-20	61.00	FR-062-20X	67.80
.069	.0345	.375	.250	.100	.187	.3750	2.5	FR-069-4	61.00	FR-069-4X	67.80
.069	.0345	.375	.375	.100	.187	.3750	2.5	FR-069-6	61.00	FR-069-6X	67.80
.069	.0345	.375	.500	.100	.187	.3750	2.5	FR-069-8	61.00	FR-069-8X	67.80
.069	.0345	.375	.750	.100	.187	.3750	2.5	FR-069-12	61.00	FR-069-12X	67.80
.069	.0345	.375	1.000	.100	.187	.3750	2.5	FR-069-16	61.00	FR-069-16X	67.80
.069	.0345	.375	1.250	.100	.187	.3750	2.5	FR-069-20	61.00	FR-069-20X	67.80
.087	.0435	.375	.250	.100	.187	.3750	2.5	FR-087-4	61.00	FR-087-4X	67.80
.087	.0435	.375	.375	.100	.187	.3750	2.5	FR-087-6	61.00	FR-087-6X	67.80
.087	.0435	.375	.500	.100	.187	.3750	2.5	FR-087-8	61.00	FR-087-8X	67.80
.087	.0435	.375	.750	.100	.187	.3750	2.5	FR-087-12	61.00	FR-087-12X	67.80
.087	.0435	.375	1.000	.100	.187	.3750	2.5	FR-087-16	61.00	FR-087-16X	67.80
.087	.0435	.375	1.250	.100	.187	.3750	2.5	FR-087-20	61.00	FR-087-20X	67.80
.093	.0465	.500	.500	.150	.250	.5000	3.0	FR-093-8	83.85	FR-093-8X	92.05
.093	.0465	.500	.750	.150	.250	.5000	3.0	FR-093-12	83.85	FR-093-12X	92.05
.093	.0465	.500	1.000	.150	.250	.5000	3.0	FR-093-16	83.85	FR-093-16X	92.05
.093	.0465	.500	1.250	.150	.250	.5000	3.0	FR-093-20	83.85	FR-093-20X	92.05
.093	.0465	.500	1.500	.150	.250	.5000	3.0	FR-093-24	83.85	FR-093-24X	92.05
.125	.0625	.500	.500	.150	.250	.5000	3.0	FR-125-8	83.85	FR-125-8X	92.05
.125	.0625	.500	.750	.150	.250	.5000	3.0	FR-125-12	83.85	FR-125-12X	92.05
.125	.0625	.500	1.000	.150	.250	.5000	3.0	FR-125-16	83.85	FR-125-16X	92.05
.125	.0625	.500	1.250	.150	.250	.5000	3.0	FR-125-20	83.85	FR-125-20X	92.05
.125	.0625	.500	1.500	.150	.250	.5000	3.0	FR-125-24	83.85	FR-125-24X	92.05
.187	.0935	.500	.500	.150	.250	.5000	3.0	FR-187-8	83.85	FR-187-8X	92.05
.187	.0935	.500	.750	.150	.250	.5000	3.0	FR-187-12	83.85	FR-187-12X	92.05
.187	.0935	.500	1.000	.150	.250	.5000	3.0	FR-187-16	83.85	FR-187-16X	92.05
.187	.0935	.500	1.250	.150	.250	.5000	3.0	FR-187-20	83.85	FR-187-20X	92.05
.187	.0935	.500	1.500	.150	.250	.5000	3.0	FR-187-24	83.85	FR-187-24X	92.05

Standard – Grooving Tools

UC

Standard – Grooving Tools  
Undercutting – Square

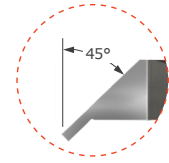
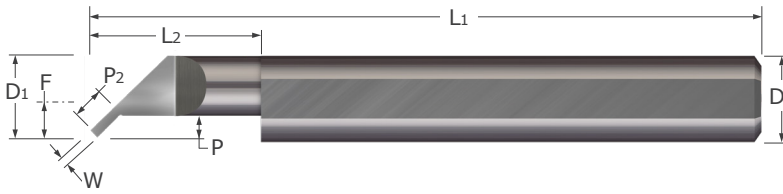

- Designed for plunging square undercut grooves
- Polished split face for improved edge retention and chip evacuation while reducing galling
- Sharp corner profile
- Lockdown flat automatically locates tool on center
- AlTiN coated option provides added lubricity and increased wear resistance in difficult to machine materials
- Solid carbide ■ CNC ground in the USA

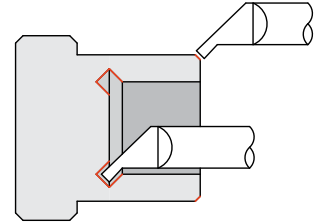

Width	Projection	Angled Projection	Minimum Bore Diameter	Maximum Bore Depth	Centerline Offset	Shank Diameter	Overall Length	Uncoated		AlTiN Coated	
								Tool #	Price	Tool #	Price
W $\begin{smallmatrix} +.002" \\ -.000" \end{smallmatrix}$	P	P <sub>2</sub>	D <sub>1</sub>	L <sub>2</sub> $\begin{smallmatrix} +.050" \\ -.000" \end{smallmatrix}$	F	D <sub>2</sub> (h6)	L <sub>1</sub>	Tool #	Price	Tool #	Price
.030	.060	.080	.240	.500	.115	.2500	2.5	UC-25030-8	34.85	UC-25030-8X	39.75
.050	.083	.120	.303	.500	.147	.3125	2.5	UC-31050-8	43.40	UC-31050-8X	50.20
.062	.083	.120	.303	1.000	.147	.3125	2.5	UC-31062-16	43.40	UC-31062-16X	50.20
.062	.083	.120	.303	1.250	.147	.3125	2.5	UC-31062-20	43.40	UC-31062-20X	50.20
.062	.095	.130	.365	1.000	.178	.3750	2.5	UC-37062-16	57.25	UC-37062-16X	64.05
.062	.125	.180	.490	1.000	.240	.5000	3.0	UC-50062-16	80.20	UC-50062-16X	88.40
.062	.125	.180	.490	1.500	.240	.5000	3.0	UC-50062-24	80.20	UC-50062-24X	88.40
.093	.095	.130	.365	1.000	.178	.3750	2.5	UC-37093-16	57.25	UC-37093-16X	64.05
.093	.125	.180	.490	1.500	.240	.5000	3.0	UC-50093-24	80.20	UC-50093-24X	88.40
.125	.095	.130	.365	1.000	.178	.3750	2.5	UC-37125-16	57.25	UC-37125-16X	64.05
.125	.095	.130	.365	1.250	.178	.3750	2.5	UC-37125-20	57.25		
.125	.125	.180	.490	1.000	.240	.5000	3.0	UC-50125-16	80.20	UC-50125-16X	88.40
.125	.125	.180	.490	1.500	.240	.5000	3.0	UC-50125-24	80.20	UC-50125-24X	88.40

# Standard – Grooving Tools

UP

## Undercutting – Full Radius

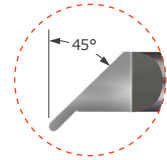
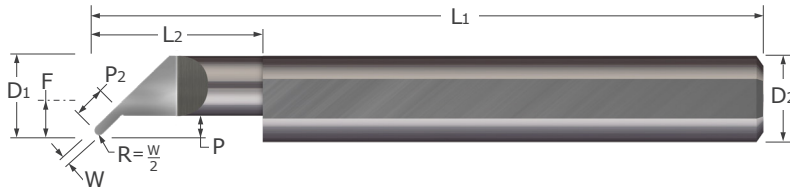

- Designed for plunging full radius undercut grooves and profiling
- Polished split face for improved edge retention and chip evacuation while reducing galling
- Full radius profile
- Lockdown flat automatically locates tool on center
- AlTiN coated option provides added lubricity and increased wear resistance in difficult to machine materials
- Solid carbide ■ CNC ground in the USA

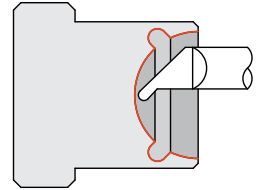

Standard – Grooving Tools

Width	Projection	Angled Projection	Minimum Bore Diameter	Maximum Bore Depth	Centerline Offset	Shank Diameter	Overall Length	Uncoated		AlTiN Coated	
								Tool #	Price	Tool #	Price
W $\begin{matrix} +.002" \\ -.000" \end{matrix}$	P	P2	D1	L2 $\begin{matrix} +.050" \\ -.000" \end{matrix}$	F	D2 (h6)	L1				
.020	.050	.077	.180	.375	.086	.1875	2.0	UP-18020-6	37.20	UP-18020-6X	40.10
.020	.050	.077	.180	.500	.086	.1875	2.0	UP-18020-8	37.20	UP-18020-8X	40.10
.025	.050	.078	.180	.375	.086	.1875	2.0	UP-18025-6	37.20	UP-18025-6X	40.10
.025	.050	.078	.180	.500	.086	.1875	2.0	UP-18025-8	37.20	UP-18025-8X	40.10
.025	.060	.092	.240	.375	.115	.2500	2.5	UP-25025-6	40.05	UP-25025-6X	44.95
.025	.060	.092	.240	.500	.115	.2500	2.5	UP-25025-8	40.05	UP-25025-8X	44.95
.030	.050	.079	.180	.375	.086	.1875	2.0	UP-18030-6	37.20	UP-18030-6X	40.10
.030	.050	.079	.180	.500	.086	.1875	2.0	UP-18030-8	37.20	UP-18030-8X	40.10
.030	.060	.094	.240	.500	.115	.2500	2.5	UP-25030-8	40.05	UP-25030-8X	44.95
.030	.060	.094	.240	1.000	.115	.2500	2.5	UP-25030-16	40.05	UP-25030-16X	44.95
.050	.083	.132	.303	.500	.147	.3125	2.5	UP-31050-8	49.85	UP-31050-8X	56.65
.050	.083	.132	.303	1.000	.147	.3125	2.5	UP-31050-16	49.85	UP-31050-16X	56.65
.062	.083	.136	.303	1.000	.147	.3125	2.5	UP-31062-16	49.85	UP-31062-16X	56.65
.062	.083	.136	.303	1.250	.147	.3125	2.5	UP-31062-20	49.85	UP-31062-20X	56.65
.062	.095	.153	.365	1.000	.178	.3750	2.5	UP-37062-16	63.75	UP-37062-16X	70.55
.062	.095	.153	.365	1.250	.178	.3750	2.5	UP-37062-20	63.75	UP-37062-20X	70.55
.062	.125	.195	.490	1.000	.240	.5000	3.0	UP-50062-16	87.95	UP-50062-16X	96.15
.062	.125	.195	.490	1.500	.240	.5000	3.0	UP-50062-24	87.95	UP-50062-24X	96.15
.093	.095	.162	.365	1.000	.178	.3750	2.5	UP-37093-16	63.75	UP-37093-16X	70.55
.093	.125	.204	.490	1.000	.240	.5000	3.0	UP-50093-16	87.95	UP-50093-16X	96.15
.093	.125	.204	.490	1.500	.240	.5000	3.0	UP-50093-24	87.95	UP-50093-24X	96.15
.125	.095	.171	.365	1.000	.178	.3750	2.5	UP-37125-16	63.75	UP-37125-16X	70.55
.125	.095	.171	.365	1.250	.178	.3750	2.5	UP-37125-20	63.75	UP-37125-20X	70.55
.125	.125	.213	.490	1.000	.240	.5000	3.0	UP-50125-16	87.95	UP-50125-16X	96.15
.125	.125	.213	.490	1.500	.240	.5000	3.0	UP-50125-24	87.95	UP-50125-24X	96.15



OR

## Standard – Grooving Tools O-Ring Grooving

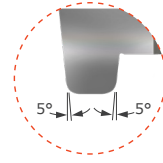
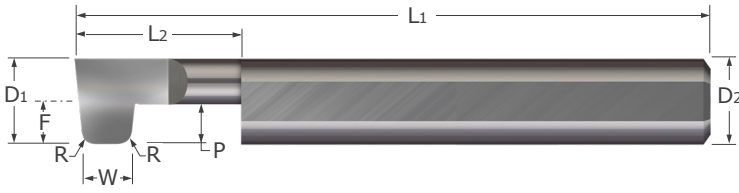

- Designed for creating O-ring grooves
- Polished split face for improved edge retention and chip evacuation while reducing galling
- Lockdown flat automatically locates tool on center
- AlTiN coated option provides added lubricity and increased wear resistance in difficult to machine materials
- Solid carbide ■ CNC ground in the USA

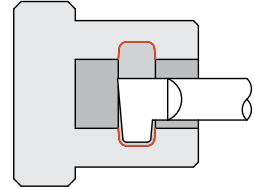

Width	Minimum Bore Diameter	Maximum Bore Depth	Radius	Projection	Centerline Offset	Shank Diameter	Overall Length	Uncoated		AlTiN Coated	
								Tool #	Price	Tool #	Price
$W \begin{smallmatrix} +.002'' \\ -.000'' \end{smallmatrix}$	D1	$L2 \begin{smallmatrix} +.050'' \\ -.000'' \end{smallmatrix}$	$R \begin{smallmatrix} +.010'' \\ -.000'' \end{smallmatrix}$	P	F	D2 (h6)	L1	OR-096-8	33.60	OR-096-8X	38.50
.096	.250	.500	.010	.100	.125	.2500	2.5	OR-141-9	33.60	OR-141-9X	38.50
.141	.250	.562	.035	.100	.125	.2500	2.5	OR-144-10	33.60	OR-144-10X	38.50
.144	.250	.625	.035	.100	.125	.2500	2.5	OR-174-12	55.15	OR-174-12X	61.95
.174	.375	.750	.010	.115	.187	.3750	2.5	OR-208-13	55.15	OR-208-13X	61.95
.208	.375	.812	.035	.115	.187	.3750	2.5	OR-241-15	55.15	OR-241-15X	61.95
.241	.375	.938	.035	.115	.187	.3750	2.5				

# Standard – Grooving Tools

FG

## Face Grooving – Square

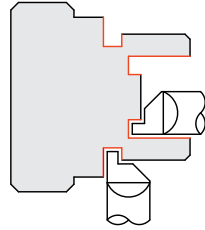
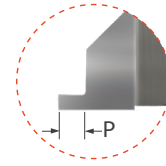
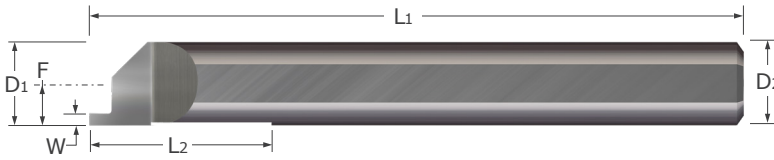

- Designed for generating square grooves in the face of the part
- Polished split face for improved edge retention and chip evacuation while reducing galling
- Split geometry makes the tool as rigid as possible
- Relief ground along Maximum Bore Depth (L<sub>2</sub>) to avoid interference during deep hole applications
- Sharp corner profile
- Lockdown flat automatically locates tool on center
- AlTiN coated option provides added lubricity and increased wear resistance in difficult to machine materials ■ Solid carbide ■ CNC ground in the USA

Standard – Grooving Tools

Width		Projection	Minimum Groove Diameter	Maximum Bore Depth	Centerline Offset	Shank Diameter	Overall Length	Uncoated		AlTiN Coated	
W	<sup>+0.002"</sup> -0.000"	P	D <sub>1</sub>	L <sub>2</sub>	F	D <sub>2</sub> (h6)	L <sub>1</sub>	Tool #	Price	Tool #	Price
.015		.025	.197	.750	.093	.1875	2.0	FG-187-015-025	24.20	FG-187-015-025X	27.10
.015		.025	.260	1.000	.125	.2500	2.5	FG-250-015-025	26.95	FG-250-015-025X	31.85
.017		.025	.197	.750	.093	.1875	2.0	FG-187-017-025	24.20	FG-187-017-025X	27.10
.017		.025	.260	1.000	.125	.2500	2.5	FG-250-017-025	26.95	FG-250-017-025X	31.85
.020		.025	.135	.375	.063	.1250	1.5	FG-125-020-025	23.40	FG-125-020-025X	25.90
.020		.025	.197	.750	.093	.1875	2.0	FG-187-020-025	24.20	FG-187-020-025X	27.10
.020		.025	.260	1.000	.125	.2500	2.5	FG-250-020-025	26.95	FG-250-020-025X	31.85
.020		.050	.190	.155	.086	.1875	2.0	FG-180-020	24.20	FG-180-020X	27.10
.020		.050	.197	.750	.093	.1875	2.0	FG-187-020-050	24.20	FG-187-020-050X	27.10
.020		.050	.240	.215	.120	.2500	2.5	FG-230-020	26.95	FG-230-020X	29.85
.020		.050	.260	.215	.125	.2500	2.5	FG-250-020	26.95	FG-250-020X	31.85
.025		.025	.135	.375	.063	.1250	1.5	FG-125-025-025	23.40	FG-125-025-025X	25.90
.025		.025	.197	.750	.093	.1875	2.0	FG-187-025-025	24.20	FG-187-025-025X	27.10
.025		.025	.260	1.000	.125	.2500	2.5	FG-250-025-025	26.95	FG-250-025-025X	31.85
.025		.050	.197	.750	.093	.1875	2.0	FG-187-025-050	24.20	FG-187-025-050X	27.10
.025		.050	.260	1.000	.125	.2500	2.5	FG-250-025-050	26.95	FG-250-025-050X	31.85
.030		.050	.135	.375	.063	.1250	1.5	FG-125-030-050	23.40	FG-125-030-050X	25.90
.030		.050	.190	.155	.086	.1875	2.0	FG-180-030	24.20	FG-180-030X	29.10
.030		.050	.197	.750	.093	.1875	2.0	FG-187-030-050	24.20	FG-187-030-050X	27.10
.030		.050	.260	.215	.125	.2500	2.5	FG-250-030	26.95	FG-250-030X	31.85
.030		.050	.322	.240	.156	.3125	2.5	FG-312-030	36.85	FG-312-030X	43.65
.030		.050	.385	.275	.188	.3750	2.5	FG-375-030	51.30	FG-375-030X	58.10
.030		.075	.197	.750	.093	.1875	2.0	FG-187-030-075	24.20	FG-187-030-075X	27.10
.030		.075	.260	1.000	.125	.2500	2.5	FG-250-030-075	26.95	FG-250-030-075X	31.85
.039		.050	.197	.750	.093	.1875	2.0	FG-187-039-050	24.20	FG-187-039-050X	27.10
.039		.050	.260	1.000	.125	.2500	2.5	FG-250-039-050	26.95	FG-250-039-050X	31.85
.039		.050	.385	1.250	.188	.3750	2.5	FG-375-039-050	51.30	FG-375-039-050X	58.10
.039		.075	.197	.750	.093	.1875	2.0	FG-187-039-075	24.20	FG-187-039-075X	27.10
.039		.075	.260	1.000	.125	.2500	2.5	FG-250-039-075	26.95	FG-250-039-075X	31.85
.040		.050	.197	.750	.093	.1875	2.0	FG-187-040-050	24.20	FG-187-040-050X	27.10
.040		.050	.260	.215	.125	.2500	2.5	FG-250-040	26.95	FG-250-040X	31.85
.040		.050	.322	.240	.156	.3125	2.5	FG-312-040	36.85	FG-312-040X	43.65
.040		.050	.385	1.250	.188	.3750	2.5	FG-375-040-050	51.30	FG-375-040-050X	58.10
.040		.075	.197	.750	.093	.1875	2.0	FG-187-040-075	24.20	FG-187-040-075X	27.10
.040		.075	.260	1.000	.125	.2500	2.5	FG-250-040-075	26.95	FG-250-040-075X	31.85

Continued on next page

## FG

Standard – Grooving Tools  
Face Grooving – Square (cont.)

Continued from previous page

Width	Projection	Minimum Groove Diameter	Maximum Bore Depth	Centerline Offset	Shank Diameter	Overall Length	Uncoated		AlTiN Coated	
W $\begin{smallmatrix} +.002" \\ -.000" \end{smallmatrix}$	P $\begin{smallmatrix} +.015" \\ -.000" \end{smallmatrix}$	D <sub>1</sub>	L <sub>2</sub>	F	D <sub>2</sub> (h6)	L <sub>1</sub>	Tool #	Price	Tool #	Price
.050	.050	.197	.750	.093	.1875	2.0	FG-187-050-050	24.20	FG-187-050-050X	27.10
.050	.050	.260	.215	.125	.2500	2.5	FG-250-050	26.95	FG-250-050X	31.85
.050	.050	.322	.240	.156	.3125	2.5	FG-312-050	36.85	FG-312-050X	43.65
.050	.050	.385	1.250	.188	.3750	2.5	FG-375-050-050	51.30	FG-375-050-050X	58.10
.050	.075	.197	.750	.093	.1875	2.0	FG-187-050-075	24.20	FG-187-050-075X	27.10
.050	.075	.260	1.000	.125	.2500	2.5	FG-250-050-075	26.95	FG-250-050-075X	31.85
.050	.075	.322	1.125	.156	.3125	2.5	FG-312-050-075	36.85	FG-312-050-075X	43.65
.059	.075	.197	.750	.093	.1875	2.0	FG-187-059-075	24.20	FG-187-059-075X	27.10
.059	.075	.260	1.000	.125	.2500	2.5	FG-250-059-075	26.95	FG-250-059-075X	31.85
.059	.075	.385	1.250	.188	.3750	2.5	FG-375-059-075	51.30	FG-375-059-075X	58.10
.059	.100	.197	.750	.093	.1875	2.0	FG-187-059-100	24.20	FG-187-059-100X	27.10
.059	.100	.260	1.000	.125	.2500	2.5	FG-250-059-100	26.95	FG-250-059-100X	31.85
.062	.075	.197	.750	.093	.1875	2.0	FG-187-062-075	24.20	FG-187-062-075X	27.10
.062	.075	.260	1.000	.125	.2500	2.5	FG-250-062-075	26.95	FG-250-062-075X	31.85
.062	.075	.322	.250	.156	.3125	2.5	FG-312-062	36.85	FG-312-062X	43.65
.062	.075	.385	.285	.188	.3750	2.5	FG-375-062	51.30	FG-375-062X	58.10
.062	.075	.510	.350	.250	.5000	3.0	FG-500-062	58.05	FG-500-062X	66.25
.062	.075	.635	.410	.313	.6250	3.5	FG-625-062	94.55	FG-625-062X	106.95
.062	.100	.197	.750	.093	.1875	2.0	FG-187-062-100	24.20	FG-187-062-100X	27.10
.062	.100	.260	1.000	.125	.2500	2.5	FG-250-062-100	26.95	FG-250-062-100X	31.85
.062	.100	.322	1.125	.156	.3125	2.5	FG-312-062-100	36.85	FG-312-062-100X	43.65
.062	.100	.385	1.250	.188	.3750	2.5	FG-375-062-100	51.30	FG-375-062-100X	58.10
.062	.150	.197	.750	.093	.1875	2.0	FG-187-062-150	24.20	FG-187-062-150X	27.10
.062	.150	.260	1.000	.125	.2500	2.5	FG-250-062-150	26.95	FG-250-062-150X	31.85
.062	.150	.322	1.125	.156	.3125	2.5	FG-312-062-150	36.85	FG-312-062-150X	43.65
.062	.150	.385	1.250	.188	.3750	2.5	FG-375-062-150	51.30	FG-375-062-150X	58.10
.078	.100	.260	1.000	.125	.2500	2.5	FG-250-078-100	26.95	FG-250-078-100X	31.85
.078	.100	.322	1.125	.156	.3125	2.5	FG-312-078-100	36.85	FG-312-078-100X	43.65
.078	.100	.385	.300	.188	.3750	2.5	FG-375-078	51.30	FG-375-078X	58.10
.093	.100	.385	.320	.188	.3750	2.5	FG-375-093	51.30	FG-375-093X	58.10
.093	.100	.510	.375	.250	.5000	3.0	FG-500-093	58.05	FG-500-093X	66.25
.093	.100	.635	.430	.313	.6250	3.5	FG-625-093	94.55	FG-625-093X	106.95
.093	.100	.760	.475	.375	.7500	4.0	FG-750-093	150.50	FG-750-093X	164.80
.093	.150	.322	1.125	.156	.3125	2.5	FG-312-093-150	36.85	FG-312-093-150X	43.65
.093	.150	.385	1.250	.188	.3750	2.5	FG-375-093-150	51.30	FG-375-093-150X	58.10
.118	.150	.385	1.250	.188	.3750	2.5	FG-375-118-150	51.30	FG-375-118-150X	58.10
.125	.100	.385	.320	.188	.3750	2.5	FG-375-125	51.30	FG-375-125X	58.10
.125	.100	.510	.350	.250	.5000	3.0	FG-500-125	58.05	FG-500-125X	66.25
.125	.100	.760	.475	.375	.7500	4.0	FG-750-125	150.50	FG-750-125X	164.80
.125	.200	.385	1.250	.188	.3750	2.5	FG-375-125-200	51.30	FG-375-125-200X	58.10
.156	.100	.510	.375	.250	.5000	3.0	FG-500-156	58.05	FG-500-156X	66.25
.156	.100	.635	.430	.313	.6250	3.5	FG-625-156	94.55	FG-625-156X	106.95
.156	.100	.635	.475	.375	.7500	4.0	FG-750-156	150.50		
.187	.150	.635	.480	.313	.6250	3.5	FG-625-187	94.55	FG-625-187X	106.95
.187	.150	.760	.525	.375	.7500	4.0	FG-750-187	150.50	FG-750-187X	164.80
.250	.250	.760	.625	.375	.7500	4.0	FG-750-250	150.50	FG-750-250X	164.80

# Standard – Grooving Tools

## Face Grooving – Corner Radius

FGC

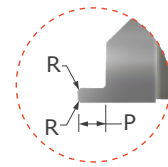
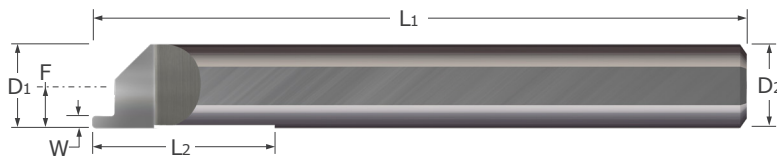

- Designed for generating corner radius grooves in the face of the part
- Polished split face for improved edge retention and chip evacuation while reducing galling
- Split geometry makes the tool as rigid as possible
- Relief ground along Maximum Bore Depth (L2) to avoid interference during deep hole applications
- Corner radius profile
- Lockdown flat automatically locates tool on center
- AlTiN coated option provides added lubricity and increased wear resistance in difficult to machine materials
- Solid carbide ■ CNC ground in the USA

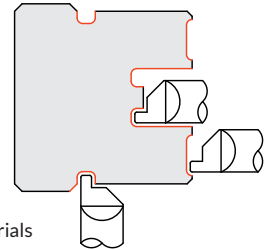

Standard – Grooving Tools

Width	Projection	Minimum Groove Diameter	Radius	Maximum Bore Depth	Centerline Offset	Shank Diameter	Overall Length	Uncoated		AlTiN Coated	
								Tool #	Price	Tool #	Price
W $^{+.002"}_{-.000"}$	P $^{+.015"}_{-.000"}$	D1	R $^{+.001"}_{-.001"}$	L2	F	D2 (h6)	L1	Tool #	Price	Tool #	Price
.015	.025	.197	.003	.750	.093	.1875	2.0	FGC3-187-015-025	25.90	FGC3-187-015-025X	28.80
.015	.025	.260	.003	1.000	.125	.2500	2.5	FGC3-250-015-025	28.70	FGC3-250-015-025X	33.60
.017	.025	.197	.003	.750	.093	.1875	2.0	FGC3-187-017-025	25.90	FGC3-187-017-025X	28.80
.017	.025	.260	.003	1.000	.125	.2500	2.5	FGC3-250-017-025	28.70	FGC3-250-017-025X	33.60
.020	.025	.135	.003	.375	.063	.1250	1.5	FGC3-125-020-025	25.10	FGC3-125-020-025X	27.60
.020	.025	.197	.003	.750	.093	.1875	2.0	FGC3-187-020-025	25.90	FGC3-187-020-025X	28.80
.020	.025	.260	.003	1.000	.125	.2500	2.5	FGC3-250-020-025	28.70	FGC3-250-020-025X	33.60
.025	.025	.135	.003	.375	.063	.1250	1.5	FGC3-125-025-025	25.10	FGC3-125-025-025X	27.60
.025	.025	.197	.003	.750	.093	.1875	2.0	FGC3-187-025-025	25.90	FGC3-187-025-025X	28.80
.025	.025	.260	.003	1.000	.125	.2500	2.5	FGC3-250-025-025	28.70	FGC3-250-025-025X	33.60
.030	.050	.135	.003	.375	.063	.1250	1.5	FGC3-125-030-050	25.10	FGC3-125-030-050X	27.60
.030	.050	.197	.003	.750	.093	.1875	2.0	FGC3-187-030-050	25.90	FGC3-187-030-050X	28.80
.030	.050	.260	.003	1.000	.125	.2500	2.5	FGC3-250-030-050	28.70	FGC3-250-030-050X	33.60
.030	.050	.322	.003	1.125	.156	.3125	2.5	FGC3-312-030-050	38.60	FGC3-312-030-050X	45.40
.030	.050	.385	.003	1.250	.188	.3750	2.5	FGC3-375-030-050	53.00	FGC3-375-030-050X	59.80
.039	.050	.197	.003	.750	.093	.1875	2.0	FGC3-187-039-050	25.90	FGC3-187-039-050X	28.80
.039	.050	.260	.003	1.000	.125	.2500	2.5	FGC3-250-039-050	28.70	FGC3-250-039-050X	33.60
.039	.050	.385	.003	1.250	.188	.3750	2.5	FGC3-375-039-050	53.00	FGC3-375-039-050X	59.80
.040	.050	.197	.003	.750	.093	.1875	2.0	FGC3-187-040-050	25.90	FGC3-187-040-050X	28.80
.040	.050	.260	.003	1.000	.125	.2500	2.5	FGC3-250-040-050	28.70	FGC3-250-040-050X	33.60
.040	.050	.322	.003	1.125	.156	.3125	2.5	FGC3-312-040-050	38.60	FGC3-312-040-050X	45.40
.040	.050	.385	.003	1.250	.188	.3750	2.5	FGC3-375-040-050	53.00	FGC3-375-040-050X	59.80
.050	.050	.197	.003	.750	.093	.1875	2.0	FGC3-187-050-050	25.90	FGC3-187-050-050X	28.80
.050	.050	.260	.003	1.000	.125	.2500	2.5	FGC3-250-050-050	28.70	FGC3-250-050-050X	33.60
.050	.050	.322	.003	1.125	.156	.3125	2.5	FGC3-312-050-050	38.60	FGC3-312-050-050X	45.40
.050	.050	.385	.003	1.250	.188	.3750	2.5	FGC3-375-050-050	53.00	FGC3-375-050-050X	59.80
.059	.075	.385	.003	1.250	.188	.3750	2.5	FGC3-375-059-075	53.00	FGC3-375-059-075X	59.80

Continued on next page

## FGC

## Standard – Grooving Tools

### Face Grooving – Corner Radius (cont.)

Continued from previous page

Width	Projection	Minimum Groove Diameter	Radius	Maximum Bore Depth	Centerline Offset	Shank Diameter	Overall Length	Uncoated		AlTiN Coated	
								Tool #	Price	Tool #	Price
W $^{+.002"}_{-.000"}$	P $^{+.015"}_{-.000"}$	D1	R $^{+.001"}_{-.001"}$	L2	F	D2 (h6)	L1				
.062	.075	.197	.003	.750	.093	.1875	2.0	FGC3-187-062-075	25.90	FGC3-187-062-075X	28.80
.062	.075	.260	.003	1.000	.125	.2500	2.5	FGC3-250-062-075	28.70	FGC3-250-062-075X	33.60
.062	.075	.322	.003	1.125	.156	.3125	2.5	FGC3-312-062-075	38.60	FGC3-312-062-075X	45.40
.062	.075	.385	.003	1.250	.188	.3750	2.5	FGC3-375-062-075	53.00	FGC3-375-062-075X	59.80
.062	.100	.197	.003	.750	.093	.1875	2.0	FGC3-187-062-100	25.90	FGC3-187-062-100X	28.80
.062	.100	.260	.003	1.000	.125	.2500	2.5	FGC3-250-062-100	28.70	FGC3-250-062-100X	33.60
.078	.100	.260	.003	1.000	.125	.2500	2.5	FGC3-250-078-100	28.70	FGC3-250-078-100X	33.60
.078	.100	.322	.003	1.125	.156	.3125	2.5	FGC3-312-078-100	38.60	FGC3-312-078-100X	45.40
.078	.100	.385	.003	1.250	.188	.3750	2.5	FGC3-375-078-100	53.00	FGC3-375-078-100X	59.80
.093	.100	.385	.006	1.250	.188	.3750	2.5	FGC6-375-093-100	53.00	FGC6-375-093-100X	59.80
.093	.150	.322	.006	1.125	.156	.3125	2.5	FGC6-312-093-150	38.60	FGC6-312-093-150X	45.40
.118	.150	.385	.006	1.250	.188	.3750	2.5	FGC6-375-118-150	53.00	FGC6-375-118-150X	59.80
.125	.100	.385	.006	1.250	.188	.3750	2.5	FGC6-375-125-100	53.00	FGC6-375-125-100X	59.80

# Standard – Grooving Tools

FGF

## Face Grooving – Full Radius

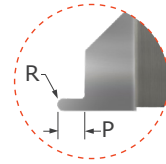
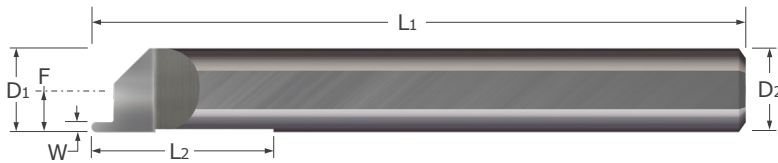

- Designed for generating full radius grooves in the face of the part
- Polished split face for improved edge retention and chip evacuation while reducing galling
- Split geometry makes the tool as rigid as possible
- Relief ground along Maximum Bore Depth (L2) to avoid interference during deep hole applications
- Full radius profile
- Lockdown flat automatically locates tool on center
- AlTiN coated option provides added lubricity and increased wear resistance in difficult to machine materials
- Solid carbide ■ CNC ground in the USA

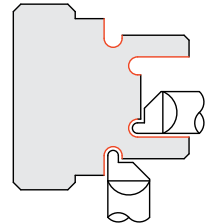

Standard – Grooving Tools

Width	Radius	Projection	Minimum Groove Diameter	Maximum Bore Depth	Centerline Offset	Shank Diameter	Overall Length	Uncoated		AlTiN Coated	
								Tool #	Price	Tool #	Price
W $^{+.002"}_{-.000"}$	R	P $^{+.015"}_{-.000"}$	D1	L2	F	D2 (h6)	L1				
.015	.008	.025	.197	.750	.093	.1875	2.0	FGF-187-015-025	24.70	FGF-187-015-025X	27.60
.015	.008	.025	.260	1.000	.125	.2500	2.5	FGF-250-015-025	27.80	FGF-250-015-025X	32.70
.017	.009	.025	.197	.750	.093	.1875	2.0	FGF-187-017-025	24.70	FGF-187-017-025X	27.60
.017	.009	.025	.260	1.000	.125	.2500	2.5	FGF-250-017-025	27.80	FGF-250-017-025X	32.70
.020	.010	.050	.135	.375	.063	.1250	1.5	FGF-125-020-050	23.90	FGF-125-020-050X	26.40
.020	.010	.050	.190	.180	.086	.1875	2.0	FGF-180-020	24.70	FGF-180-020X	27.60
.020	.010	.050	.197	.750	.093	.1875	2.0	FGF-187-020-050	24.70	FGF-187-020-050X	27.60
.020	.010	.050	.240	.230	.105	.2500	2.5	FGF-230-020	27.80	FGF-230-020X	32.70
.020	.010	.050	.260	.230	.125	.2500	2.5	FGF-250-020	27.80	FGF-250-020X	32.70
.025	.013	.050	.135	.375	.063	.1250	1.5	FGF-125-025-050	23.90	FGF-125-025-050X	26.40
.025	.013	.050	.197	.750	.093	.1875	2.0	FGF-187-025-050	24.70	FGF-187-025-050X	27.60
.025	.013	.050	.260	1.000	.125	.2500	2.5	FGF-250-025-050	27.80	FGF-250-025-050X	32.70
.030	.015	.050	.135	.375	.063	.1250	1.5	FGF-125-030-050	23.90	FGF-125-030-050X	26.40
.030	.015	.050	.190	.180	.086	.1875	2.0	FGF-180-030	24.70	FGF-180-030X	27.60
.030	.015	.050	.197	.750	.093	.1875	2.0	FGF-187-030-050	24.70	FGF-187-030-050X	27.60
.030	.015	.050	.260	.230	.125	.2500	2.5	FGF-250-030	27.80	FGF-250-030X	32.70
.039	.020	.075	.197	.750	.093	.1875	2.0	FGF-187-039-075	24.70	FGF-187-039-075X	27.60
.039	.020	.075	.260	1.000	.125	.2500	2.5	FGF-250-039-075	27.80	FGF-250-039-075X	32.70
.040	.020	.075	.197	.750	.093	.1875	2.0	FGF-187-040-075	24.70	FGF-187-040-075X	27.60
.040	.020	.050	.260	.230	.125	.2500	2.5	FGF-250-040	27.80	FGF-250-040X	32.70
.040	.020	.075	.260	1.000	.125	.2500	2.5	FGF-250-040-075	27.80	FGF-250-040-075X	32.70
.050	.025	.075	.197	.750	.093	.1875	2.0	FGF-187-050-075	24.70	FGF-187-050-075X	27.60
.050	.025	.075	.260	1.000	.125	.2500	2.5	FGF-250-050-075	27.80	FGF-250-050-075X	32.70
.050	.025	.050	.322	.255	.156	.3125	2.5	FGF-312-050	38.00	FGF-312-050X	44.80
.050	.025	.075	.322	1.125	.156	.3125	2.5	FGF-312-050-075	38.00	FGF-312-050-075X	44.80
.062	.031	.100	.197	.750	.093	.1875	2.0	FGF-187-062-100	24.70	FGF-187-062-100X	27.60
.062	.031	.100	.260	1.000	.125	.2500	2.5	FGF-250-062-100	27.80	FGF-250-062-100X	32.70
.062	.031	.075	.322	.280	.156	.3125	2.5	FGF-312-062	38.00	FGF-312-062X	44.80
.062	.031	.100	.322	1.125	.156	.3125	2.5	FGF-312-062-100	38.00	FGF-312-062-100X	44.80
.062	.031	.075	.385	.315	.188	.3750	2.5	FGF-375-062	52.80	FGF-375-062X	59.60
.062	.031	.100	.385	1.250	.188	.3750	2.5	FGF-375-062-100	52.80	FGF-375-062-100X	59.60
.078	.039	.100	.385	.335	.188	.3750	2.5	FGF-375-078	52.80	FGF-375-078X	59.60
.093	.047	.100	.385	.335	.188	.3750	2.5	FGF-375-093	52.80	FGF-375-093X	59.60
.125	.063	.100	.385	.335	.188	.3750	2.5	FGF-375-125	52.80	FGF-375-125X	59.60

IT

## Standard – Threading Tools

### UN Threads – Single Point – Right Hand

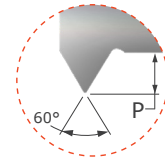
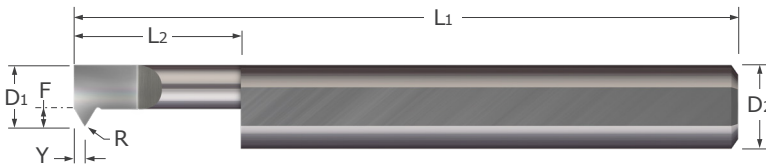

- Designed for threading multiple thread pitches (ANSI, UN, and Metric 60°)
- Polished split face for improved edge retention and chip evacuation while reducing galling
- Split geometry makes the tool as rigid as possible
- Corner radius profile
- Lockdown flat automatically locates tool on center
- AlTiN coated option provides added lubricity and increased wear resistance in difficult to machine materials
- Solid carbide ■ CNC ground in the USA

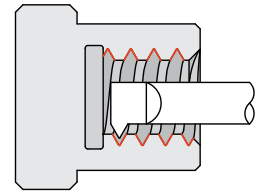

Threads Per Inch	Minimum Bore Diameter	Maximum Bore Depth	Point Offset	Projection	Radius	Centerline Offset	Shank Diameter	Overall Length	Uncoated		AlTiN Coated	
									Tool #	Price	Tool #	Price
TPI	D <sub>1</sub>	L <sub>2</sub>	$Y^{+.010"}_{-.000"}$	P	$R^{+.001"}_{-.000"}$	F	D <sub>2</sub> (h6)	L <sub>1</sub>	Tool #	Price	Tool #	Price
56-76	.040	.075	.009	.015	.001	-.023	.1250	1.5	IT-040075	39.20	IT-040075X	41.70
56-76	.040	.100	.009	.015	.001	-.023	.1250	1.5	IT-040100	39.20	IT-040100X	41.70
56-76	.040	.150	.009	.015	.001	-.023	.1250	1.5	IT-040150	39.20	IT-040150X	41.70
48-76	.050	.100	.012	.020	.001	-.013	.1250	1.5	IT-050100	39.20	IT-050100X	41.70
48-76	.050	.150	.012	.020	.001	-.013	.1250	1.5	IT-050150	39.20	IT-050150X	41.70
48-76	.050	.200	.012	.020	.001	-.013	.1250	1.5	IT-050200	39.20	IT-050200X	41.70
48-76	.060	.200	.012	.020	.001	-.003	.1250	1.5	IT-060200	34.20	IT-060200X	36.70
48-76	.060	.250	.012	.020	.001	-.003	.1250	1.5	IT-060250	34.20	IT-060250X	36.70
48-76	.060	.300	.012	.020	.001	-.003	.1250	1.5	IT-060300	34.20	IT-060300X	36.70

TPI	D <sub>1</sub>	L <sub>2</sub>	$Y^{+.010"}_{-.000"}$	P	$R^{+.001"}_{-.001"}$	F	D <sub>2</sub> (h6)	L <sub>1</sub>	Tool #	Price	Tool #	Price
40-76	.080	.250	.012	.020	.002	.018	.1250	1.5	IT-080250	31.15	IT-080250X	33.65
40-76	.080	.350	.012	.020	.002	.018	.1250	1.5	IT-080350	31.15	IT-080350X	33.65
40-76	.080	.500	.012	.020	.002	.018	.1250	1.5	IT-080500	31.15	IT-080500X	33.65
32-76	.100	.250	.014	.025	.002	.038	.1250	1.5	IT-100250	31.15	IT-100250X	33.65
32-76	.100	.350	.014	.025	.002	.038	.1250	1.5	IT-100350	31.15	IT-100350X	33.65
32-76	.100	.500	.014	.025	.002	.038	.1250	1.5	IT-100500	31.15	IT-100500X	33.65
32-76	.100	.600	.014	.025	.002	.038	.1250	1.5	IT-100600	31.15	IT-100600X	33.65
32-56	.120	.250	.017	.030	.002	.026	.1875	2.0	IT-120250	33.15	IT-120250X	36.05
32-56	.120	.400	.017	.030	.002	.026	.1875	2.0	IT-120400	33.15	IT-120400X	36.05
32-56	.120	.500	.017	.030	.002	.026	.1875	2.0	IT-120500	33.15	IT-120500X	36.05
32-56	.120	.600	.017	.030	.002	.026	.1875	2.0	IT-120600	33.15	IT-120600X	36.05
32-56	.120	.750	.017	.030	.002	.026	.1875	2.0	IT-120750	33.15	IT-120750X	36.05
28-56	.140	.250	.020	.035	.002	.046	.1875	2.0	IT-140250	33.15	IT-140250X	36.05
28-56	.140	.400	.020	.035	.002	.046	.1875	2.0	IT-140400	33.15	IT-140400X	36.05
28-56	.140	.500	.020	.035	.002	.046	.1875	2.0	IT-140500	33.15	IT-140500X	36.05
28-56	.140	.750	.020	.035	.002	.046	.1875	2.0	IT-140750	33.15	IT-140750X	36.05

Continued on next page

# Standard – Threading Tools

IT

## UN Threads – Single Point – Right Hand (cont.)

Continued from previous page

Threads Per Inch	Minimum Bore Diameter	Maximum Bore Depth	Point Offset	Projection	Radius	Centerline Offset	Shank Diameter	Overall Length	Uncoated		AITIN Coated	
									Tool #	Price	Tool #	Price
TPI	D1	L2 <sup>+ .050"</sup> <sub>-.000"</sub>	Y <sup>+ .010"</sup> <sub>-.000"</sub>	P	R <sup>+ .001"</sup> <sub>-.001"</sub>	F	D2 (h6)	L1	Tool #	Price	Tool #	Price
24-56	.160	.250	.023	.040	.002	.066	.1875	2.0	IT-160250	33.15	IT-160250X	36.05
24-56	.160	.400	.023	.040	.002	.066	.1875	2.0	IT-160400	33.15	IT-160400X	36.05
24-56	.160	.500	.023	.040	.002	.066	.1875	2.0	IT-160500	33.15	IT-160500X	36.05
24-56	.160	.750	.023	.040	.002	.066	.1875	2.0	IT-160750	33.15	IT-160750X	36.05
24-56	.160	1.000	.023	.040	.002	.066	.1875	2.0	IT-1601000	33.15	IT-1601000X	36.05
24-56	.180	.350	.023	.040	.002	.055	.2500	2.5	IT-180350	35.45	IT-180350X	40.35
24-56	.180	.500	.023	.040	.002	.055	.2500	2.5	IT-180500	35.45	IT-180500X	40.35
24-56	.180	.750	.023	.040	.002	.055	.2500	2.5	IT-180750	35.45	IT-180750X	40.35
24-56	.180	1.000	.023	.040	.002	.055	.2500	2.5	IT-1801000	35.45	IT-1801000X	40.35
24-40	.200	.400	.026	.045	.002	.075	.2500	2.5	IT-200400	35.45	IT-200400X	40.35
24-40	.200	.600	.026	.045	.002	.075	.2500	2.5	IT-200600	35.45	IT-200600X	40.35
24-40	.200	.750	.026	.045	.002	.075	.2500	2.5	IT-200750	35.45	IT-200750X	40.35
24-40	.200	1.000	.026	.045	.002	.075	.2500	2.5	IT-2001000	35.45	IT-2001000X	40.35
20-40	.230	.400	.032	.055	.002	.074	.3125	2.5	IT-230400	44.35	IT-230400X	51.15
20-40	.230	.600	.032	.055	.002	.074	.3125	2.5	IT-230600	44.35	IT-230600X	51.15
20-40	.230	.750	.032	.055	.002	.074	.3125	2.5	IT-230750	44.35	IT-230750X	51.15
20-40	.230	1.000	.032	.055	.002	.074	.3125	2.5	IT-2301000	44.35	IT-2301000X	51.15
20-40	.230	1.500	.032	.055	.002	.074	.3125	2.5	IT-2301500	44.35	IT-2301500X	51.15
14-40	.290	.500	.040	.070	.002	.134	.3125	2.5	IT-290500	44.35	IT-290500X	51.15
14-40	.290	.750	.040	.070	.002	.134	.3125	2.5	IT-290750	44.35	IT-290750X	51.15
14-40	.290	1.000	.040	.070	.002	.134	.3125	2.5	IT-2901000	44.35	IT-2901000X	51.15
14-40	.290	1.250	.040	.070	.002	.134	.3125	2.5	IT-2901250	44.35	IT-2901250X	51.15
14-40	.290	1.750	.040	.070	.002	.134	.3125	2.5	IT-2901750	44.35	IT-2901750X	51.15
10-32	.320	.500	.043	.075	.002	.133	.3750	2.5	IT-320500	57.75	IT-320500X	64.55
10-32	.320	.750	.043	.075	.002	.133	.3750	2.5	IT-320750	57.75	IT-320750X	64.55
10-32	.320	1.000	.043	.075	.002	.133	.3750	2.5	IT-3201000	57.75	IT-3201000X	64.55
10-32	.320	1.250	.043	.075	.002	.133	.3750	2.5	IT-3201250	57.75	IT-3201250X	64.55
10-32	.320	1.800	.043	.075	.002	.133	.3750	2.5	IT-3201800	57.75	IT-3201800X	64.55
10-32	.360	.500	.049	.085	.002	.173	.3750	2.5	IT-360500	57.75	IT-360500X	64.55
10-32	.360	.750	.049	.085	.002	.173	.3750	2.5	IT-360750	57.75	IT-360750X	64.55
10-32	.360	1.000	.049	.085	.002	.173	.3750	2.5	IT-3601000	57.75	IT-3601000X	64.55
10-32	.360	1.250	.049	.085	.002	.173	.3750	2.5	IT-3601250	57.75	IT-3601250X	64.55
10-32	.360	1.800	.049	.085	.002	.173	.3750	2.5	IT-3601800	57.75	IT-3601800X	64.55
6-24	.490	.750	.069	.120	.002	.240	.5000	3.0	IT-490750	81.00	IT-490750X	89.20
6-24	.490	1.500	.069	.120	.002	.240	.5000	3.0	IT-4901500	81.00	IT-4901500X	89.20
6-24	.490	2.000	.069	.120	.002	.240	.5000	3.0	IT-4902000	81.00	IT-4902000X	89.20

Standard – Threading Tools



See pg 257 for tool set options



ITL

Standard – Threading Tools  
UN Threads – Single Point – Left Hand

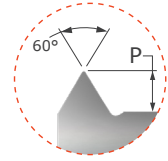
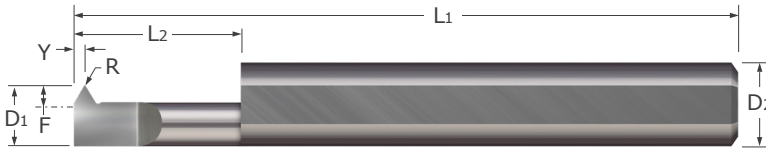

- Designed for threading multiple thread pitches (ANSI, UN, and Metric 60°) in a left hand threading application
- Polished split face for improved edge retention and chip evacuation while reducing galling
- Split geometry makes the tool as rigid as possible
- Corner radius profile
- Lockdown flat automatically locates tool on center
- AlTiN coated option provides added lubricity and increased wear resistance in difficult to machine materials
- Solid carbide ■ CNC ground in the USA

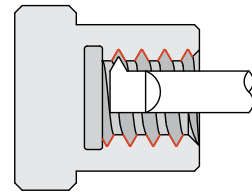

Threads Per Inch	Minimum Bore Diameter	Maximum Bore Depth	Point Offset	Projection	Radius	Centerline Offset	Shank Dia.	Overall Length	Uncoated		AlTiN Coated	
									Tool #	Price	Tool #	Price
TPI	D1	L2 <sup>+0.050"</sup> / <sub>-.000"</sub>	Y <sup>+0.010"</sup> / <sub>-.000"</sub>	P	R <sup>+0.001"</sup> / <sub>-.000"</sub>	F	D2 (h6)	L1	Tool #	Price	Tool #	Price
56 - 76	.040	.075	.009	.015	.001	-.023	.1250	1.5	ITL-040075	39.20		
56 - 76	.040	.150	.009	.015	.001	-.023	.1250	1.5	ITL-040150	39.20		
48 - 76	.050	.200	.012	.020	.001	-.013	.1250	1.5	ITL-050200	39.20	ITL-050200X	41.70
48 - 76	.060	.200	.012	.020	.001	-.003	.1250	1.5	ITL-060200	34.20	ITL-060200X	36.70
48 - 76	.060	.250	.012	.020	.001	-.003	.1250	1.5	ITL-060250	34.20	ITL-060250X	36.70
48 - 76	.060	.300	.012	.020	.001	-.003	.1250	1.5	ITL-060300	34.20	ITL-060300X	36.70

Threads Per Inch	Minimum Bore Diameter	Maximum Bore Depth	Point Offset	Projection	Radius	Centerline Offset	Shank Dia.	Overall Length	Uncoated		AlTiN Coated	
									Tool #	Price	Tool #	Price
TPI	D1	L2 <sup>+0.050"</sup> / <sub>-.000"</sub>	Y <sup>+0.010"</sup> / <sub>-.000"</sub>	P	R <sup>+0.001"</sup> / <sub>-.001"</sub>	F	D2 (h6)	L1	Tool #	Price	Tool #	Price
40 - 76	.080	.250	.012	.020	.002	.018	.1250	1.5	ITL-080250	31.15	ITL-080250X	33.65
40 - 76	.080	.350	.012	.020	.002	.018	.1250	1.5	ITL-080350	31.15	ITL-080350X	33.65
40 - 76	.080	.500	.012	.020	.002	.018	.1250	1.5	ITL-080500	31.15	ITL-080500X	33.65
32 - 76	.100	.250	.014	.025	.002	.038	.1250	1.5	ITL-100250	31.15	ITL-100250X	33.65
32 - 76	.100	.350	.014	.025	.002	.038	.1250	1.5	ITL-100350	31.15	ITL-100350X	33.65
32 - 76	.100	.500	.014	.025	.002	.038	.1250	1.5	ITL-100500	31.15	ITL-100500X	33.65
32 - 76	.100	.600	.014	.025	.002	.038	.1250	1.5	ITL-100600	31.15	ITL-100600X	33.65
32 - 56	.120	.250	.017	.030	.002	.026	.1875	2.0	ITL-120250	33.15	ITL-120250X	36.05
32 - 56	.120	.400	.017	.030	.002	.026	.1875	2.0	ITL-120400	33.15	ITL-120400X	36.05
32 - 56	.120	.500	.017	.030	.002	.026	.1875	2.0	ITL-120500	33.15	ITL-120500X	36.05
32 - 56	.120	.600	.017	.030	.002	.026	.1875	2.0	ITL-120600	33.15	ITL-120600X	36.05
32 - 56	.120	.750	.017	.030	.002	.026	.1875	2.0	ITL-120750	33.15	ITL-120750X	36.05
28 - 56	.140	.250	.020	.035	.002	.046	.1875	2.0	ITL-140250	33.15	ITL-140250X	36.05
28 - 56	.140	.400	.020	.035	.002	.046	.1875	2.0	ITL-140400	33.15	ITL-140400X	36.05
28 - 56	.140	.500	.020	.035	.002	.046	.1875	2.0	ITL-140500	33.15	ITL-140500X	36.05
28 - 56	.140	.750	.020	.035	.002	.046	.1875	2.0	ITL-140750	33.15	ITL-140750X	36.05

Continued on next page

# Standard – Threading Tools

ITL

## UN Threads – Single Point – Left Hand (cont.)

Continued from previous page

Threads Per Inch	Minimum Bore Diameter	Maximum Bore Depth	Point Offset	Projection	Radius	Centerline Offset	Shank Dia.	Overall Length	Uncoated		AlTiN Coated	
									Tool #	Price	Tool #	Price
TPI	D1	L2 $\begin{matrix} +.050'' \\ -.000'' \end{matrix}$	Y $\begin{matrix} +.010'' \\ -.000'' \end{matrix}$	P	R $\begin{matrix} +.001'' \\ -.001'' \end{matrix}$	F	D2 (h6)	L1	Tool #	Price	Tool #	Price
24 - 56	.160	.250	.023	.040	.002	.066	.1875	2.0	ITL-160250	33.15	ITL-160250X	36.05
24 - 56	.160	.400	.023	.040	.002	.066	.1875	2.0	ITL-160400	33.15	ITL-160400X	36.05
24 - 56	.160	.500	.023	.040	.002	.066	.1875	2.0	ITL-160500	33.15	ITL-160500X	36.05
24 - 56	.160	.750	.023	.040	.002	.066	.1875	2.0	ITL-160750	33.15	ITL-160750X	36.05
24 - 56	.180	.350	.023	.040	.002	.055	.2500	2.5	ITL-180350	35.45	ITL-180350X	40.35
24 - 56	.180	.500	.023	.040	.002	.055	.2500	2.5	ITL-180500	35.45	ITL-180500X	40.35
24 - 56	.180	.750	.023	.040	.002	.055	.2500	2.5	ITL-180750	35.45	ITL-180750X	40.35
24 - 56	.180	1.000	.023	.040	.002	.055	.2500	2.5	ITL-1801000	35.45	ITL-1801000X	40.35
24 - 40	.200	.400	.026	.045	.002	.075	.2500	2.5	ITL-200400	35.45	ITL-200400X	40.35
24 - 40	.200	.600	.026	.045	.002	.075	.2500	2.5	ITL-200600	35.45	ITL-200600X	40.35
24 - 40	.200	.750	.026	.045	.002	.075	.2500	2.5	ITL-200750	35.45	ITL-200750X	40.35
24 - 40	.200	1.000	.026	.040	.002	.075	.2500	2.5	ITL-2001000	35.45	ITL-2001000X	40.35
20 - 40	.230	.400	.032	.055	.002	.074	.3125	2.5	ITL-230400	44.35	ITL-230400X	51.15
20 - 40	.230	.600	.032	.055	.002	.074	.3125	2.5	ITL-230600	44.35	ITL-230600X	51.15
20 - 40	.230	.750	.032	.055	.002	.074	.3125	2.5	ITL-230750	44.35	ITL-230750X	51.15
20 - 40	.230	1.000	.032	.055	.002	.074	.3125	2.5	ITL-2301000	44.35	ITL-2301000X	51.15
14 - 40	.290	.500	.040	.070	.002	.134	.3125	2.5	ITL-290500	44.35	ITL-290500X	51.15
14 - 40	.290	.750	.040	.070	.002	.134	.3125	2.5	ITL-290750	44.35	ITL-290750X	51.15
14 - 40	.290	1.000	.040	.070	.002	.134	.3125	2.5	ITL-2901000	44.35	ITL-2901000X	51.15
14 - 40	.290	1.250	.040	.070	.002	.134	.3125	2.5	ITL-2901250	44.35	ITL-2901250X	51.15
10 - 32	.320	.500	.043	.075	.002	.133	.3750	2.5	ITL-320500	57.75	ITL-320500X	64.55
10 - 32	.320	.750	.043	.075	.002	.133	.3750	2.5	ITL-320750	57.75	ITL-320750X	64.55
10 - 32	.320	1.000	.043	.075	.002	.133	.3750	2.5	ITL-3201000	57.75	ITL-3201000X	64.55
10 - 32	.320	1.250	.043	.075	.002	.133	.3750	2.5	ITL-3201250	57.75	ITL-3201250X	64.55
10 - 32	.360	.500	.049	.085	.002	.173	.3750	2.5	ITL-360500	57.75	ITL-360500X	64.55
10 - 32	.360	.750	.049	.085	.002	.173	.3750	2.5	ITL-360750	57.75	ITL-360750X	64.55
10 - 32	.360	1.000	.049	.085	.002	.173	.3750	2.5	ITL-3601000	57.75	ITL-3601000X	64.55
10 - 32	.360	1.250	.049	.085	.002	.173	.3750	2.5	ITL-3601250	57.75	ITL-3601250X	64.55
10 - 32	.360	1.800	.049	.085	.002	.173	.3750	2.5	ITL-3601800	57.75	ITL-3601800X	64.55
6 - 24	.490	.750	.069	.120	.002	.240	.5000	3.0	ITL-490750	81.00	ITL-490750X	89.20
6 - 24	.490	1.500	.069	.120	.002	.240	.5000	3.0	ITL-4901500	81.00	ITL-4901500X	89.20
6 - 24	.490	2.000	.069	.120	.002	.240	.5000	3.0	ITL-4902000	81.00	ITL-4902000X	89.20

Standard – Threading Tools

ITM

Standard – Threading Tools  
Metric Shank – Single Point – Right Hand

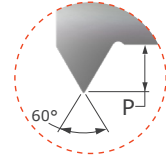
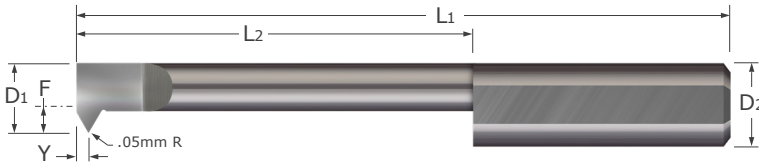

- Designed for threading multiple thread pitches (ANSI, UN, & Metric 60°)
- Polished split face for improved edge retention and chip evacuation while reducing galling
- Split geometry makes the tool as rigid as possible
- Corner radius profile
- Lockdown flat automatically locates tool on center
- AlTiN coated option provides added lubricity and increased wear resistance in difficult to machine materials
- Solid carbide ■ CNC ground in the USA

Pitch	Minimum Bore Diameter		Maximum Bore Depth		Point Offset	Projection	Centerline Offset	Shank Dia.	OAL	Uncoated		TIN Coated		AITIN Coated	
	D1	L2	L2	Y						P	F	D2 (h6)	L1	Tool #	Price
.70-1.5 mm	4.60 mm	13 mm	13 mm	0.71 mm	1.22 mm	1.6 mm	6 mm	57 mm	ITM-064613	34.95	ITM-064613G	38.25	ITM-064613X	39.85	
.70-1.5 mm	4.60 mm	25 mm	25 mm	0.71 mm	1.22 mm	1.6 mm	6 mm	57 mm	ITM-064625	34.95	ITM-064625G	38.25	ITM-064625X	39.85	
1.2-1.7 mm	5.10 mm	15 mm	15 mm	0.76 mm	1.32 mm	2.1 mm	6 mm	57 mm	ITM-065115	34.95			ITM-065115X	39.85	
1.2-1.7 mm	5.10 mm	28 mm	28 mm	0.76 mm	1.32 mm	2.1 mm	6 mm	57 mm	ITM-065128	34.95			ITM-065128X	39.85	
1.2-2.0 mm	5.80 mm	15 mm	15 mm	0.86 mm	1.50 mm	1.8 mm	8 mm	63 mm	ITM-085815	42.15			ITM-085815X	48.95	
1.2-2.0 mm	5.80 mm	25 mm	25 mm	0.86 mm	1.50 mm	1.8 mm	8 mm	63 mm	ITM-085825	42.15			ITM-085825X	48.95	
1.2-2.0 mm	5.80 mm	38 mm	38 mm	0.86 mm	1.50 mm	1.8 mm	8 mm	63 mm	ITM-085838	42.15	ITM-085838G	47.05	ITM-085838X	48.95	
1.7-2.2 mm	7.40 mm	20 mm	20 mm	1.09 mm	1.91 mm	3.4 mm	8 mm	63 mm	ITM-087420	42.15	ITM-087420G	47.05	ITM-087420X	48.95	
1.7-2.2 mm	7.40 mm	32 mm	32 mm	1.09 mm	1.91 mm	3.4 mm	8 mm	63 mm	ITM-087432	42.15	ITM-087432G	47.05	ITM-087432X	48.95	
1.7-2.2 mm	7.40 mm	46 mm	46 mm	1.09 mm	1.91 mm	3.4 mm	8 mm	63 mm	ITM-087446	42.15	ITM-087446G	47.05	ITM-087446X	48.95	
1.75-3.0 mm	9.60 mm	20 mm	20 mm	1.40 mm	2.41 mm	4.6 mm	10 mm	72 mm	ITM-109620	59.15					
2.0-4.0 mm	11.40 mm	50 mm	50 mm	1.85 mm	3.23 mm	5.4 mm	12 mm	83 mm	ITM-121150	75.80					

Standard – Threading Tools

# Standard – Threading Tools

IAT

## ACME Threads

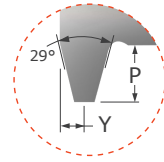
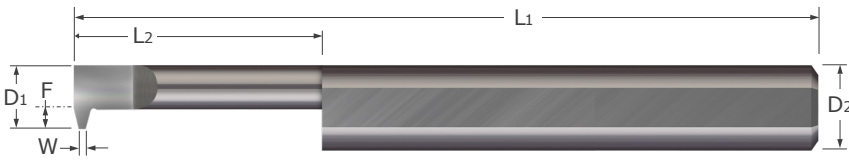

- Designed for cutting pitch-specific ACME threads
- Polished split face for improved edge retention and chip evacuation while reducing galling
- Split geometry makes the tool as rigid as possible
- Lockdown flat automatically locates tool on center
- AlTiN coated option provides added lubricity and increased wear resistance in difficult to machine materials
- Solid carbide ■ CNC ground in the USA

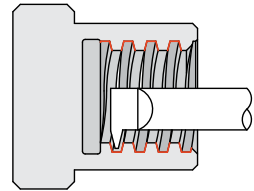

Standard – Threading Tools

Threads Per Inch	Minimum Bore Diameter		Maximum Bore Depth		Point Offset	Projection	Flat	Centerline Offset	Shank Diameter	Overall Length	Uncoated		AlTiN Coated	
	D1	L2	$L_2^{+.050/-0.000}$	Y							P	$W^{+.000/-0.005}$	F	D2 (h6)
16	.200	.400	.035	.045	.021	.075	.2500	2.5	IAT-400-16	35.45	IAT-400-16X	40.35		
16	.200	.600	.024	.045	.021	.075	.2500	2.5	IAT-600-16	35.45	IAT-600-16X	40.35		
16	.200	.750	.035	.045	.021	.075	.2500	2.5	IAT-750-16	35.45	IAT-750-16X	40.35		
16	.200	1.000	.035	.045	.021	.075	.2500	2.5	IAT-1000-16	35.45	IAT-1000-16X	40.35		
14	.255	.500	.043	.070	.024	.099	.3125	2.5	IAT-500-14	43.85	IAT-500-14X	50.65		
14	.255	.750	.030	.070	.024	.099	.3125	2.5	IAT-750-14	43.85	IAT-750-14X	50.65		
14	.255	1.000	.043	.070	.024	.099	.3125	2.5	IAT-1000-14	43.85	IAT-1000-14X	50.65		
14	.255	1.250	.043	.070	.024	.099	.3125	2.5	IAT-1250-14	43.85	IAT-1250-14X	50.65		
12	.360	.750	.049	.085	.028	.173	.3750	2.5	IAT-750-12	57.75	IAT-750-12X	64.55		
12	.360	1.000	.036	.085	.028	.173	.3750	2.5	IAT-1000-12	57.75	IAT-1000-12X	64.55		
12	.360	1.250	.049	.085	.028	.173	.3750	2.5	IAT-1250-12	57.75	IAT-1250-12X	64.55		
12	.360	1.800	.049	.085	.028	.173	.3750	2.5	IAT-1800-12	57.75	IAT-1800-12X	64.55		
10	.490	.750	.060	.120	.032	.240	.5000	3.0	IAT-750-10	81.00	IAT-750-10X	89.20		
10	.490	1.500	.060	.120	.032	.240	.5000	3.0	IAT-1500-10	81.00	IAT-1500-10X	89.20		
10	.490	2.000	.060	.120	.032	.240	.5000	3.0	IAT-2000-10	81.00	IAT-2000-10X	89.20		
8	.490	.750	.064	.120	.041	.240	.5000	3.0	IAT-750-8	81.00	IAT-750-8X	89.20		
8	.490	1.500	.064	.120	.041	.240	.5000	3.0	IAT-1500-8	81.00	IAT-1500-8X	89.20		
8	.490	2.000	.064	.120	.041	.240	.5000	3.0	IAT-2000-8	81.00	IAT-2000-8X	89.20		
6	.490	.750	.072	.120	.057	.240	.5000	3.0	IAT-750-6	81.00	IAT-750-6X	89.20		
6	.490	1.500	.072	.120	.057	.240	.5000	3.0	IAT-1500-6	81.00	IAT-1500-6X	89.20		
6	.490	2.000	.072	.120	.057	.240	.5000	3.0	IAT-2000-6	81.00	IAT-2000-6X	89.20		
5	.490	1.500	.078	.120	.069	.240	.5000	3.0	IAT-1500-5	81.00	IAT-1500-5X	89.20		
5	.490	2.000	.078	.120	.069	.240	.5000	3.0	IAT-2000-5	81.00	IAT-2000-5X	89.20		

SAT

Standard – Threading Tools

Stub ACME Threads

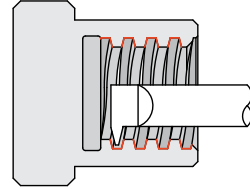
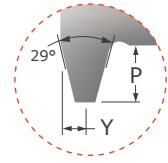
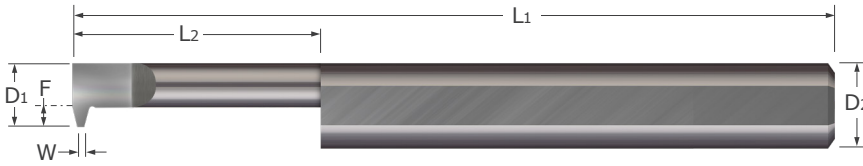

- Designed for cutting pitch-specific stub ACME threads
- Polished split face for improved edge retention and chip evacuation while reducing galling
- Split geometry makes the tool as rigid as possible
- Lockdown flat automatically locates tool on center
- AlTiN coated option provides added lubricity and increased wear resistance in difficult to machine materials
- Solid carbide ■ CNC ground in the USA

Threads Per Inch	Minimum Bore Diameter		Maximum Bore Depth		Point Offset	Projection	Flat	Centerline Offset	Shank Diameter	Overall Length	Uncoated		AlTiN Coated	
	D1	L2	$^{+.050}$ $_{-.000}$ "	Y							P	$^{+.000}$ $_{-.005}$ "	F	D2 (h6)
16	.200	.400	.400	.024	.045	.024	.075	.2500	2.5	SAT-400-16	35.45	SAT-400-16X	40.35	
16	.200	.600	.600	.036	.045	.024	.075	.2500	2.5	SAT-600-16	35.45	SAT-600-16X	40.35	
16	.200	.750	.750	.024	.045	.024	.075	.2500	2.5	SAT-750-16	35.45	SAT-750-16X	40.35	
16	.200	1.000	1.000	.024	.045	.024	.075	.2500	2.5	SAT-1000-16	35.45	SAT-1000-16X	40.35	
14	.235	.500	.500	.045	.070	.028	.079	.3125	2.5	SAT-500-14	43.85	SAT-500-14X	50.65	
14	.235	.750	.750	.045	.070	.028	.079	.3125	2.5	SAT-750-14	43.85	SAT-750-14X	50.65	
14	.235	1.000	1.000	.045	.070	.028	.079	.3125	2.5	SAT-1000-14	43.85	SAT-1000-14X	50.65	
14	.235	1.750	1.750	.045	.070	.028	.079	.3125	2.5	SAT-1750-14	43.85	SAT-1750-14X	50.65	
12	.360	.500	.500	.051	.085	.033	.173	.3750	2.5	SAT-500-12	57.75	SAT-500-12X	64.55	
12	.360	.750	.750	.051	.085	.033	.173	.3750	2.5	SAT-750-12	57.75	SAT-750-12X	64.55	
12	.360	1.000	1.000	.045	.085	.033	.173	.3750	2.5	SAT-1000-12	57.75	SAT-1000-12X	64.55	
12	.360	1.250	1.250	.051	.085	.033	.173	.3750	2.5	SAT-1250-12	57.75	SAT-1250-12X	64.55	
12	.360	1.800	1.800	.051	.085	.033	.173	.3750	2.5	SAT-1800-12	57.75	SAT-1800-12X	64.55	
10	.490	.750	.750	.062	.120	.037	.240	.5000	3.0	SAT-750-10	81.00	SAT-750-10X	89.20	
10	.490	1.500	1.500	.062	.120	.037	.240	.5000	3.0	SAT-1500-10	81.00	SAT-1500-10X	89.20	
10	.490	2.000	2.000	.050	.120	.037	.240	.5000	3.0	SAT-2000-10	81.00	SAT-2000-10X	89.20	
9	.490	1.500	1.500	.052	.120	.042	.240	.5000	3.0	SAT-1500-9	81.00			
9	.490	2.000	2.000	.052	.120	.042	.240	.5000	3.0	SAT-2000-9	81.00	SAT-2000-9X	89.20	
8	.490	.750	.750	.068	.120	.048	.240	.5000	3.0	SAT-750-8	81.00	SAT-750-8X	89.20	
8	.490	1.500	1.500	.068	.120	.048	.240	.5000	3.0	SAT-1500-8	81.00	SAT-1500-8X	89.20	
8	.490	2.000	2.000	.068	.120	.048	.240	.5000	3.0	SAT-2000-8	81.00	SAT-2000-8X	89.20	
7	.490	.750	.750	.059	.120	.055	.240	.5000	3.0	SAT-750-7	81.00			
7	.490	2.000	2.000	.059	.120	.055	.240	.5000	3.0	SAT-2000-7	81.00	SAT-2000-7X	89.20	
6	.490	2.000	2.000	.064	.120	.065	.240	.5000	3.0	SAT-2000-6	81.00	SAT-2000-6X	89.20	
5	.490	.750	.750	.083	.120	.079	.240	.5000	3.0	SAT-750-5	81.00	SAT-750-5X	89.20	
5	.490	1.500	1.500	.083	.120	.079	.240	.5000	3.0	SAT-1500-5	81.00	SAT-1500-5X	89.20	
5	.490	2.000	2.000	.083	.120	.079	.240	.5000	3.0	SAT-2000-5	81.00	SAT-2000-5X	89.20	

Standard – Threading Tools

## Standard – Threading Tools

IDRT

UN Threads – Right Hand – Brazed

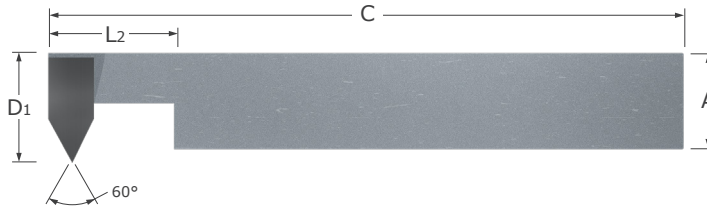

- Designed for threading multiple thread pitches (ANSI, UN and Metric 60°)
- Designed for single point threading where a square shank tool is required in .450" bores and larger
- Sharp corner profile
- Lockdown flat automatically locates tool on center
- Steel shank with brazed tip ■ CNC ground in the USA

Minimum Bore Diameter	Maximum Bore Depth	Square Shank	Overall Length	Brazed Style	
				Tool #	Price
D1	$L2^{+.050"}_{-.000"}$	$A^{+.0000"}_{-.0030"}$	C		
.450	.615	.3750	2.5	IDRT-60	50.70
.450	1.115	.3750	2.5	IDRT-61	50.70
.575	.875	.5000	3.5	IDRT-80	51.20
.575	1.395	.5000	3.5	IDRT-81	47.10

Standard – Threading Tools

## Standard – Threading Tools

IDLT

UN Threads – Left Hand – Brazed

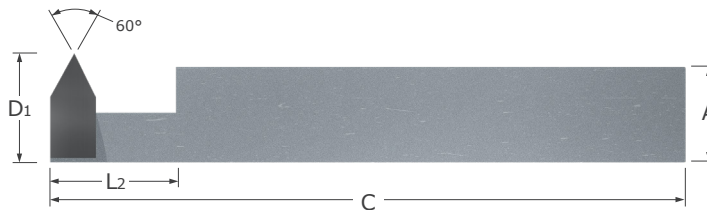

- Designed for threading multiple thread pitches (ANSI, UN, and Metric 60°) in a left hand threading application
- Designed for single point threading where a square shank tool is required in .450" bores and larger
- Sharp corner profile
- Lockdown flat automatically locates tool on center
- Steel shank with brazed tip ■ CNC ground in the USA

Minimum Bore Diameter	Maximum Bore Depth	Square Shank	Overall Length	Brazed Style	
				Tool #	Price
D1	$L2^{+.050"}_{-.000"}$	$A^{+.0000"}_{-.0030"}$	C		
.450	.615	.3750	2.5	IDLT-60	50.70
.450	1.115	.3750	2.5	IDLT-61	50.70
.575	.875	.5000	3.5	IDLT-80	51.20
.575	1.395	.5000	3.5	IDLT-81	51.20

## LTR

## Standard – Threading Tools

## Thread Relief Tools

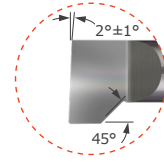
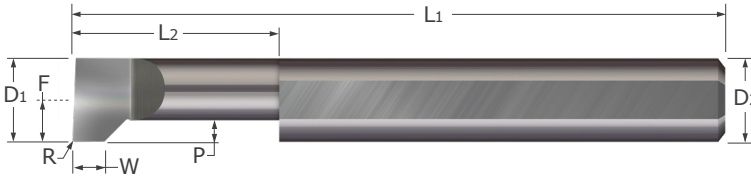

- Designed for plunging thread relief at the bottom of a thread
- Polished split face for improved edge retention and chip evacuation while reducing galling
- Split geometry makes the tool as rigid as possible
- Lockdown flat automatically locates tool on center
- AlTiN coated option provides added lubricity and increased wear resistance in difficult to machine materials
- Solid carbide ■ CNC ground in the USA

Minimum Bore Diameter	Maximum Bore Depth	Flat	Radius	Projection	Centerline Offset	Shank Diameter	Overall Length	Uncoated		AlTiN Coated	
D1	L2 $\begin{matrix} +.050'' \\ -.000'' \end{matrix}$	W $\begin{matrix} +.002'' \\ -.002'' \end{matrix}$	R $\begin{matrix} +.002'' \\ -.000'' \end{matrix}$	P	F	D2 (h6)	L1	Tool #	Price	Tool #	Price
.094	.250	.049	.002	.040	.032	.1250	1.5	LTR-094-4	25.80	LTR-094-4X	28.30
.094	.375	.049	.002	.040	.032	.1250	1.5	LTR-094-6	25.80	LTR-094-6X	28.30
.125	.375	.063	.002	.040	.063	.1250	1.5	LTR-125-6	25.80	LTR-125-6X	28.30
.125	.500	.063	.002	.040	.063	.1250	1.5	LTR-125-8	25.80	LTR-125-8X	28.30

D1	L2 $\begin{matrix} +.050'' \\ -.000'' \end{matrix}$	W $\begin{matrix} +.002'' \\ -.002'' \end{matrix}$	R $\begin{matrix} +.002'' \\ -.002'' \end{matrix}$	P	F	D2 (h6)	L1	Tool #	Price	Tool #	Price
.156	.375	.063	.005	.040	.063	.1875	2.0	LTR-156-6	29.60	LTR-156-6X	32.50
.156	.500	.063	.005	.040	.063	.1875	2.0	LTR-156-8	29.60	LTR-156-8X	32.50
.187	.375	.078	.005	.040	.094	.1875	2.0	LTR-187-6	29.60	LTR-187-6X	32.50
.187	.500	.078	.005	.040	.094	.1875	2.0	LTR-187-8	29.60	LTR-187-8X	32.50
.187	.750	.078	.005	.040	.094	.1875	2.0	LTR-187-12	29.60	LTR-187-12X	32.50
.187	1.000	.078	.005	.040	.094	.1875	2.0	LTR-187-16	29.60	LTR-187-16X	32.50
.250	.500	.094	.005	.050	.125	.2500	2.5	LTR-250-8	35.45	LTR-250-8X	40.35
.250	.750	.094	.005	.050	.125	.2500	2.5	LTR-250-12	35.45	LTR-250-12X	40.35
.250	1.000	.094	.005	.050	.125	.2500	2.5	LTR-250-16	35.45	LTR-250-16X	40.35
.250	1.250	.094	.005	.050	.125	.2500	2.5	LTR-250-20	35.45	LTR-250-20X	40.35
.312	.750	.094	.005	.075	.156	.3125	2.5	LTR-312-12	44.35	LTR-312-12X	51.15
.312	1.250	.094	.005	.075	.156	.3125	2.5	LTR-312-20	44.35	LTR-312-20X	51.15
.375	.750	.125	.005	.100	.188	.3750	2.5	LTR-375-12	58.35	LTR-375-12X	65.15
.375	1.250	.125	.005	.100	.188	.3750	2.5	LTR-375-20	58.35	LTR-375-20X	65.15
.500	1.000	.156	.010	.125	.250	.5000	3.0	LTR-500-16	82.65	LTR-500-16X	90.85
.500	1.500	.156	.010	.125	.250	.5000	3.0	LTR-500-24	82.65	LTR-500-24X	90.85

# Standard – Tool Holders

TH / THM

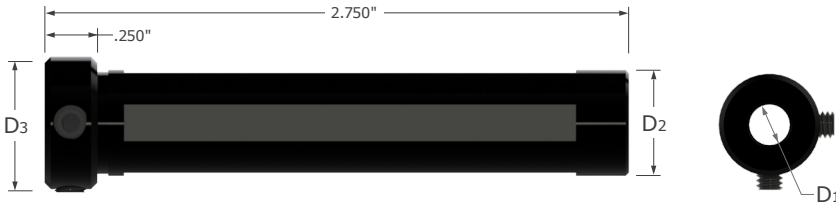

- Tool holder optimized for use with Micro 100 standard shank tools in lathe applications
- Head allows for consistent length when seated against the tooling block.
- Ability for tool to be mounted in 4 different orientations, 90 degrees apart, due to 4 alignment flats on shank
- Tools can be set at any length in the holder, allowing for maximum rigidity to reduce chatter and harmonics during machining
- Heat treated and black oxide coated for durability and corrosion resistance
- Precision manufactured in the USA

Internal Diameter		Collar Diameter	Shank Diameter	Tool Holder	
D <sub>1</sub> $\begin{matrix} +.0005" \\ -.0000" \end{matrix}$	decimal equiv.	D <sub>3</sub> $\begin{matrix} +.005" \\ -.005" \\ +.127mm \\ -.127mm \end{matrix}$	D <sub>2</sub> $\begin{matrix} -.0003" \\ -.0008" \\ -.008mm \\ -.020mm \end{matrix}$	Tool #	Price
3 mm	.1181	15 mm	12 mm	THM-312	68.00
3 mm	.1181	19 mm	16 mm	THM-316	68.00
3 mm	.1181	25 mm	20 mm	THM-320	75.00
.1250	.1250	.625	.5000	TH-84	68.00
.1250	.1250	.750	.6250	TH-104	68.00
.1250	.1250	.875	.7500	TH-204	75.00
.1250	.1250	25 mm	20 mm	THMA-420	75.00
.1250	.1250	27 mm	22 mm	THMA-422	75.00
.1250	.1250	32 mm	25 mm	THMA-425	89.00
.1250	.1250	1.250	1.0000	TH-404	89.00
4 mm	.1575	15 mm	12 mm	THM-412	68.00
4 mm	.1575	19 mm	16 mm	THM-416	68.00
4 mm	.1575	25 mm	20 mm	THM-420	75.00
.1875	.1875	.625	.5000	TH-85	68.00
.1875	.1875	.750	.6250	TH-105	68.00
.1875	.1875	.875	.7500	TH-205	75.00
.1875	.1875	25 mm	20 mm	THMA-520	75.00
.1875	.1875	27 mm	22 mm	THMA-522	75.00
.1875	.1875	32 mm	25 mm	THMA-525	89.00
.1875	.1875	1.250	1.0000	TH-405	89.00
6 mm	.2362	15 mm	12 mm	THM-612	68.00
6 mm	.2362	19 mm	16 mm	THM-616	68.00
6 mm	.2362	25 mm	20 mm	THM-620	75.00
.2500	.2500	.625	.5000	TH-86	68.00
.2500	.2500	.750	.6250	TH-106	68.00
.2500	.2500	.875	.7500	TH-206	75.00
.2500	.2500	25 mm	20 mm	THMA-620	75.00
.2500	.2500	27 mm	22 mm	THMA-622	75.00
.2500	.2500	32 mm	25 mm	THMA-625	89.00
.2500	.2500	1.250	1.0000	TH-406	89.00

Continued on next page

Standard – Tool Holders



## TH / THM

## Standard – Tool Holders

(cont.)

Continued from previous page

Internal Diameter		Collar Diameter	Shank Diameter	Tool Holder	
$D_1$ $\begin{matrix} +.0005'' \\ -.0000'' \end{matrix}$	decimal equiv.	$D_3$ $\begin{matrix} +.005'' \\ -.005'' \\ +.127\text{mm} \\ -.127\text{mm} \end{matrix}$	$D_2$ $\begin{matrix} -.0003'' \\ -.0008'' \\ -.008\text{mm} \\ -.020\text{mm} \end{matrix}$	Tool #	Price
.3125	.3125	.625	.5000	TH-87	68.00
.3125	.3125	.750	.6250	TH-107	68.00
.3125	.3125	.875	.7500	TH-207	75.00
.3125	.3125	25 mm	20 mm	THMA-720	75.00
.3125	.3125	27 mm	22 mm	THMA-722	75.00
.3125	.3125	32 mm	25 mm	THMA-725	89.00
.3125	.3125	1.250	1.0000	TH-407	89.00
8 mm	.3150	15 mm	12 mm	THM-812	68.00
8 mm	.3150	19 mm	16 mm	THM-816	68.00
8 mm	.3150	25 mm	20 mm	THM-820	75.00
.3750	.3750	.625	.5000	TH-88	68.00
.3750	.3750	.750	.6250	TH-108	68.00
.3750	.3750	.875	.7500	TH-208	75.00
.3750	.3750	25 mm	20 mm	THMA-820	75.00
.3750	.3750	27 mm	22 mm	THMA-822	75.00
.3750	.3750	32 mm	25 mm	THMA-825	89.00
.3750	.3750	1.250	1.0000	TH-408	89.00
10 mm	.3937	19 mm	16 mm	THM-1016	68.00
10 mm	.3937	25 mm	20 mm	THM-1020	75.00
12 mm	.4724	19 mm	16 mm	THM-1216	68.00
12 mm	.4724	25 mm	20 mm	THM-1220	75.00
.5000	.5000	.875	.7500	TH-210	75.00
.5000	.5000	1.125	1.0000	TH-410	89.00

## Indexable – Boring Bars

### Boring – Coolant Through – Right Hand

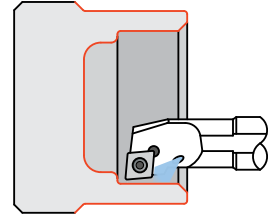
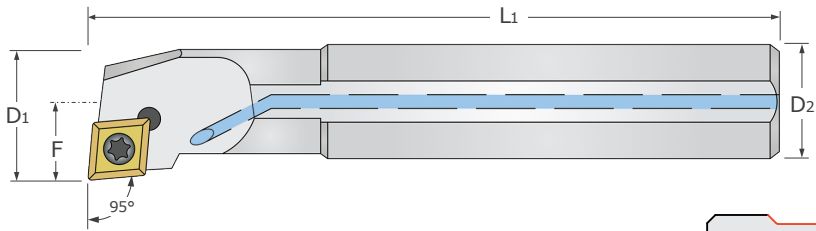

- Coolant through boring bar for right hand boring and facing with 5° approach (lead) angle
- Made from precision ground heat treated steel
- Coolant through design for improved chip removal
- Insert not included

Minimum Bore Diameter	Centerline Offset	Shank Diameter	Overall Length	Insert Part Number	Holder Nomenclature	Tool Holder	
						Tool #	Price
D <sub>1</sub>	F	D <sub>2</sub>	L <sub>1</sub>				
.330	.177	.2500	3.1	50-1100	A04F SCLCR 2	20-0821	69.65
.380	.197	.3125	3.9	50-1100	A05H SCLCR 2	20-0823	71.50
.490	.275	.3750	4.5	50-1100	A06J SCLCR 2	20-0825	74.60
.630	.354	.5000	4.9	50-1100	A08K SCLCR 2	20-0827	77.75
.630	.354	.5000	4.9	50-1105	A08K SCLCR 3	20-0850	80.85
.775	.433	.6250	5.9	50-1100	A10M SCLCR 2	20-0829	83.10
.775	.433	.6250	5.9	50-1105	A10M SCLCR 3	20-0852	86.15
.925	.511	.7500	7.0	50-1105	A12Q SCLCR 3	20-0854	93.25

See pg 283 for indexable insert accessories

See pgs 277-282 for tool set options

## Indexable – Boring Bars

### Boring – Coolant Through – Left Hand

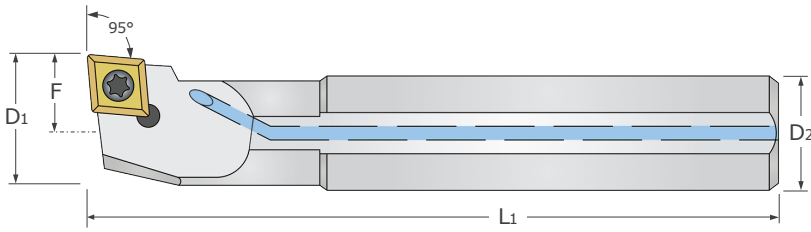

- Coolant through boring bar for left hand boring & facing with 5° approach (lead) angle
- Made from precision ground heat treated steel
- Coolant through design for improved chip removal
- Insert not included

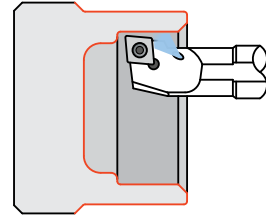

Minimum Bore Diameter	Centerline Offset	Shank Diameter	Overall Length	Insert Part Number	Holder Nomenclature	Tool Holder	
						Tool #	Price
D <sub>1</sub>	F	D <sub>2</sub>	L <sub>1</sub>				
.330	.177	.2500	3.1	50-1100	A04F SCLCL 2	20-0822	69.65
.380	.197	.3125	3.9	50-1100	A05H SCLCL 2	20-0824	71.50
.490	.275	.3750	4.5	50-1100	A06J SCLCL 2	20-0826	74.60
.630	.354	.5000	4.9	50-1100	A08K SCLCL 2	20-0828	77.75
.630	.354	.5000	4.9	50-1105	A08K SCLCL 3	20-0851	80.85
.775	.433	.6250	5.9	50-1100	A10M SCLCL 2	20-0830	83.10
.775	.433	.6250	5.9	50-1105	A10M SCLCL 3	20-0853	86.15
.925	.511	.7500	7.0	50-1105	A12Q SCLCL 3	20-0855	93.25

See pg 283 for indexable insert accessories

See pgs 277-282 for tool set options

## Indexable – Boring Bars

Facing – Coolant Through – Right Hand

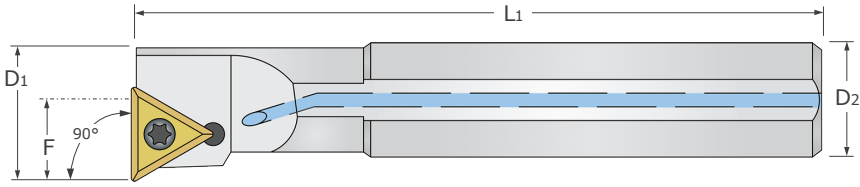

- Coolant through boring bar for left hand boring and facing with 0° approach (lead) angle, which allows for deeper roughing passes
- Made from precision ground heat treated steel
- Coolant through design for improved chip removal
- Insert not included

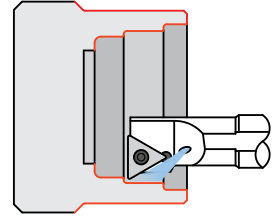

Minimum Bore Diameter	Centerline Offset	Shank Diameter	Overall Length	Insert Part Number	Holder Nomenclature	Tool Holder	
D <sub>1</sub>	F	D <sub>2</sub>	L <sub>1</sub>			Tool #	Price
.490	.275	.3750	4.3	50-1300	A06J STFCL 2	20-1031	72.80
.605	.354	.5000	4.9	50-1300	A08K STFCL 2	20-1033	77.05
.775	.433	.6250	5.9	50-1300	A10M STFCL 2	20-1035	78.05

## Indexable – Boring Bars

Facing – Coolant Through – Left Hand

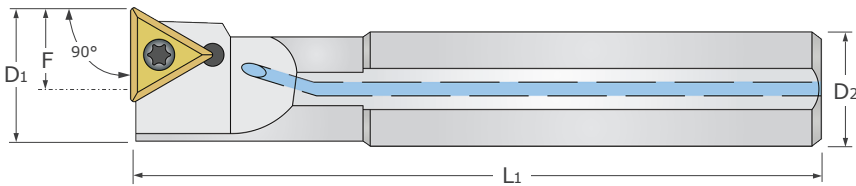

- Coolant through boring bar for left hand boring and facing with 0° approach (lead) angle, which allows for deeper roughing passes
- Made from precision ground heat treated steel
- Coolant through design for improved chip removal
- Insert not included

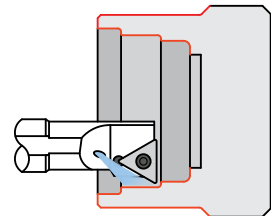

Minimum Bore Diameter	Centerline Offset	Shank Diameter	Overall Length	Insert Part Number	Holder Nomenclature	Tool Holder	
D <sub>1</sub>	F	D <sub>2</sub>	L <sub>1</sub>			Tool #	Price
.490	.275	.3750	4.3	50-1300	A06J STFCL 2	20-1032	72.80
.605	.354	.5000	4.9	50-1300	A08K STFCL 2	20-1034	77.05
.775	.433	.6250	5.9	50-1300	A10M STFCL 2	20-1036	78.05

See pg 283 for indexable insert accessories

See pgs 277-282 for tool set options

## Indexable – Boring Bars

### Profiling – Coolant Through – Right Hand

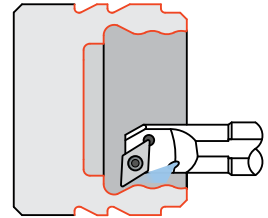
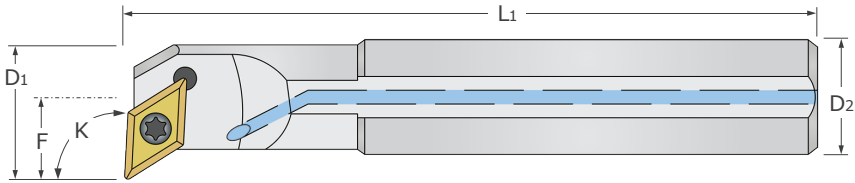

- Coolant through boring bar for right hand boring, facing, and profiling
- Made from precision ground heat treated steel
- Coolant through design for improved chip removal
- Insert not included

Minimum Bore Diameter	Centerline Offset	K Angle	Shank Diameter	Overall Length	Insert Part Number	Holder Nomenclature	Tool Holder	
							Tool #	Price
D <sub>1</sub>	F	K	D <sub>2</sub>	L <sub>1</sub>				
.425	.197	107.5°	.3125	3.9	50-1200	A05H SDQCR 2	20-0901	70.00
.490	.275	93°	.3750	4.5	50-1200	A06J SDUCR 2	20-0931	72.80
.605	.354	93°	.5000	4.9	50-1200	A08K SDUCR 2	20-0933	77.05
.775	.433	93°	.6250	5.9	50-1200	A10M SDUCR 2	20-0935	78.05

## Indexable – Boring Bars

### Profiling – Coolant Through – Left Hand

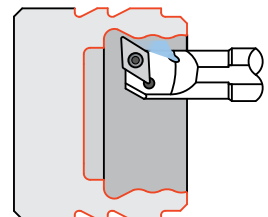
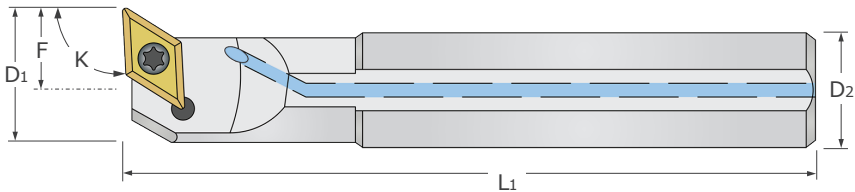

- Coolant through boring bar for left hand boring, facing, and profiling
- Made from precision ground heat treated steel
- Coolant through design for improved chip removal
- Insert not included

Minimum Bore Diameter	Centerline Offset	K Angle	Shank Diameter	Overall Length	Insert Part Number	Holder Nomenclature	Tool Holder	
							Tool #	Price
D <sub>1</sub>	F	K	D <sub>2</sub>	L <sub>1</sub>				
.425	.197	107.5°	.3125	3.9	50-1200	A05H SDQCL 2	20-0902	70.00
.490	.275	93°	.3750	4.5	50-1200	A06J SDUCL 2	20-0932	72.80
.605	.354	93°	.5000	4.9	50-1200	A08K SDUCL 2	20-0934	77.05
.775	.433	93°	.6250	5.9	50-1200	A10M SDUCL 2	20-0936	78.05

See pg 283 for indexable insert accessories

See pgs 277-282 for tool set options

Indexable

## Indexable – Tool Holders

### Chamfering & Turning – Style SCMCN

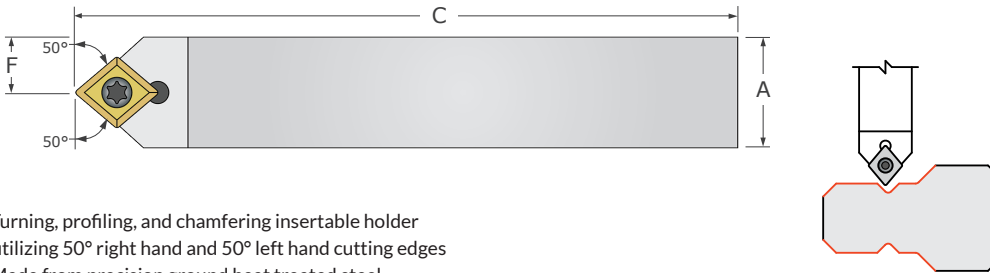

- Turning, profiling, and chamfering insertable holder utilizing 50° right hand and 50° left hand cutting edges
- Made from precision ground heat treated steel
- Insert not included

Locating Offset	Square Shank	Overall Length	Insert Part Number	Holder Nomenclature	Tool Holder	
					Tool #	Price
F	A	C				
.157	.2500	2.4	50-1100	SCMCN 0404 D2	10-3311	37.30
.157	.3125	2.4	50-1100	SCMCN 0505 D2	10-3312	40.45
.189	.3750	2.8	50-1100	SCMCN 0606 E2	10-3313	45.45
.250	.5000	3.2	50-1100	SCMCN 0808 F2	10-3314	49.70
.315	.6250	3.9	50-1100	SCMCN 1010 H2	10-3315	55.10

## Indexable – Tool Holders

### Chamfering & Turning – Style SCSCR

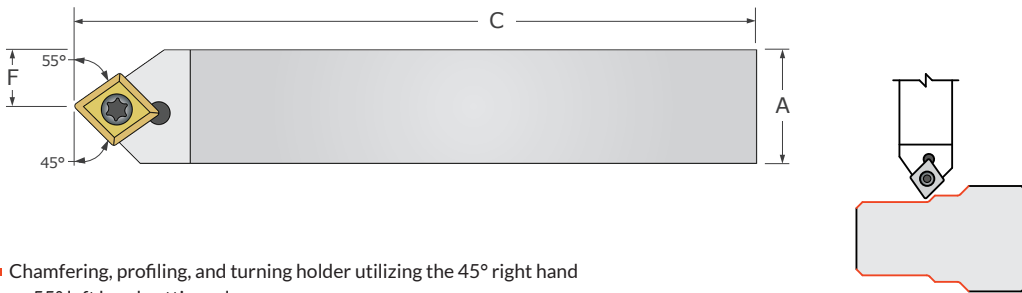

- Chamfering, profiling, and turning holder utilizing the 45° right hand or 55° left hand cutting edges
- Made from precision ground heat treated steel
- Insert not included

Locating Offset	Square Shank	Overall Length	Insert Part Number	Holder Nomenclature	Tool Holder	
					Tool #	Price
F	A	C				
.157	.2500	2.4	50-1100	SCSCR 0404 D2	10-3351	37.30
.157	.3125	2.4	50-1100	SCSCR 0505 D2	10-3353	40.45
.189	.3750	2.8	50-1100	SCSCR 0606 E2	10-3355	45.45
.250	.5000	3.2	50-1100	SCSCR 0808 F2	10-3357	49.70
.315	.6250	3.9	50-1100	SCSCR 1010 H2	10-3359	55.10
.390	.7500	4.9	50-1100	SCSCR 1212 J3	10-3365	64.70

See pg 283 for indexable insert accessories

See pgs 277-282 for tool set options

## Indexable – Tool Holders

## Facing &amp; Turning – Axial – Right Hand – Style SCKCR

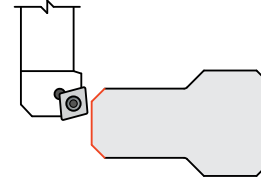
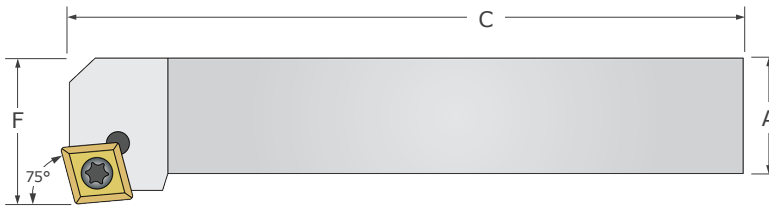

- 75° facing and chamfering holder utilizing 100° unused left hand cutting edge of insert
- Made from precision ground heat treated steel
- Insert not included

Locating Offset	Square Shank	Overall Length	Insert Part Number	Holder Nomenclature	Tool Holder	
					Tool #	Price
F	A	C				
.394	.2500	2.4	50-1100	SCKCR 0404 D2	10-3211	37.30
.394	.3125	2.4	50-1100	SCKCR 0505 D2	10-3212	40.45
.472	.3750	2.8	50-1100	SCKCR 0606 E2	10-3213	45.45
.630	.5000	3.2	50-1100	SCKCR 0808 F2	10-3215	49.70
.787	.6250	3.9	50-1100	SCKCR 1010 H2	10-3217	55.10

See pg 283 for indexable insert accessories

See pgs 277-282 for tool set options

## Indexable – Tool Holders

Facing & Turning – Radial – Right Hand – Style SCLCR

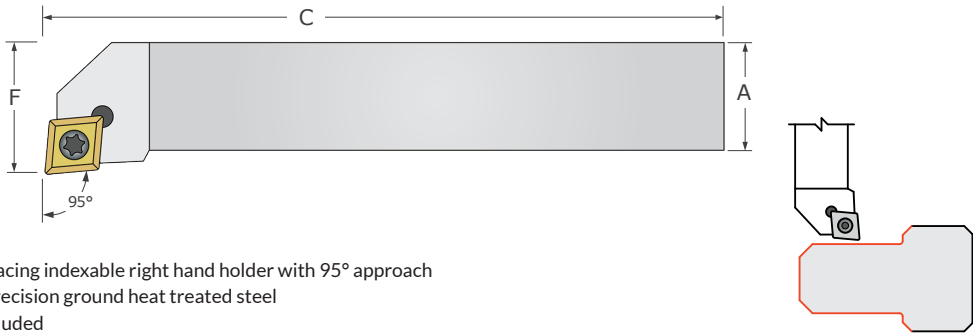

- Turning and facing indexable right hand holder with 95° approach
- Made from precision ground heat treated steel
- Insert not included

Locating Offset	Square Shank	Overall Length	Insert Part Number	Holder Nomenclature	Tool Holder	
					Tool #	Price
F	A	C				
.394	.2500	2.4	50-1100	SCLCR 0404 D2	10-3231	37.30
.394	.3125	2.4	50-1100	SCLCR 0505 D2	10-3233	40.45
.472	.3750	2.8	50-1100	SCLCR 0606 E2	10-3235	45.45
.628	.5000	3.1	50-1100	SCLCR 0808 F2	10-3237	49.70
.787	.6250	4.0	50-1100	SCLCR 1010 H2	10-3241	55.10
1.000	.7500	5.0	50-1105	SCLCR 1212 J3	10-3251	64.70

## Indexable – Tool Holders

Facing & Turning – Radial – Left Hand – Style SCLCL

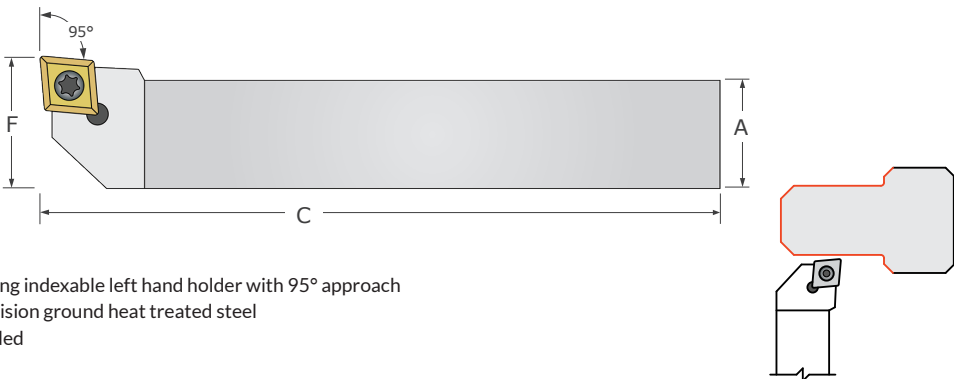

- Turning and facing indexable left hand holder with 95° approach
- Made from precision ground heat treated steel
- Insert not included

Locating Offset	Square Shank	Overall Length	Insert Part Number	Holder Nomenclature	Tool Holder	
					Tool #	Price
F	A	C				
.394	.2500	2.4	50-1100	SCLCL 0404 D2	10-3232	37.30
.394	.3125	2.4	50-1100	SCLCL 0505 D2	10-3234	40.45
.472	.3750	2.8	50-1100	SCLCL 0606 E2	10-3236	45.45
.600	.5000	3.2	50-1100	SCLCL 0808 F2	10-3238	49.70
.787	.6250	3.9	50-1100	SCLCL 1010 H2	10-3242	55.10
1.000	.7500	4.9	50-1105	SCLCL 1212 J3	10-3252	64.70

See pg 283 for indexable insert accessories

See pgs 277-282 for tool set options



## Indexable – Tool Holders

Facing &amp; Turning – Radial – Right Hand – Style SDJCR

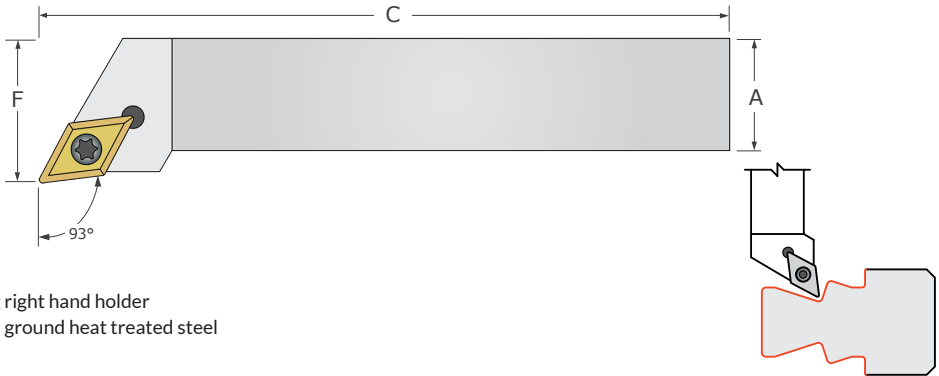

- Turning and profiling right hand holder
- Made from precision ground heat treated steel
- Insert not included

Locating Offset	Square Shank	Overall Length	Insert Part Number	Holder Nomenclature	Tool Holder	
					Tool #	Price
F	A	C				
.394	.3125	3.9	50-1200	SDJCR 0505 H2	10-3641	45.45
.472	.3750	3.9	50-1200	SDJCR 0606 H2	10-3651	53.20
.629	.5000	3.9	50-1200	SDJCR 0808H2	10-3653	56.00
.787	.6250	3.9	50-1200	SDJCR 1010 H2	10-3615	62.15

## Indexable – Tool Holders

Facing &amp; Turning – Radial – Left Hand – Style SDJCL

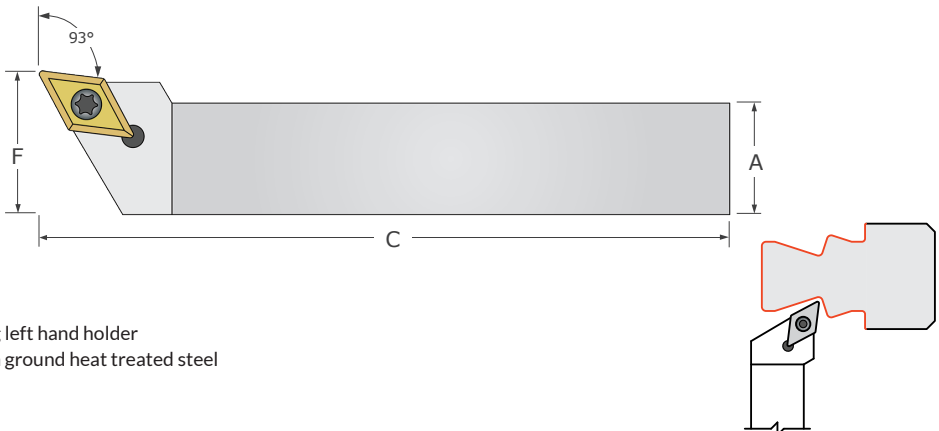

- Turning and profiling left hand holder
- Made from precision ground heat treated steel
- Insert not included

Locating Offset	Square Shank	Overall Length	Insert Part Number	Holder Nomenclature	Tool Holder	
					Tool #	Price
F	A	C				
.394	.3125	3.9	50-1200	SDJCL 0505 H2	10-3642	45.45
.472	.3750	3.9	50-1200	SDJCL 0606 H2	10-3652	53.20
.629	.7500	3.9	50-1200	SDJCL 0808H2	10-3654	56.00
.787	.6250	3.9	50-1200	SDJCL 1010 H2	10-3616	62.15

See pg 283 for indexable insert accessories

See pgs 277-282 for tool set options

## Indexable – Tool Holders

Facing & Turning – Radial – Right Hand – Style SCBCR

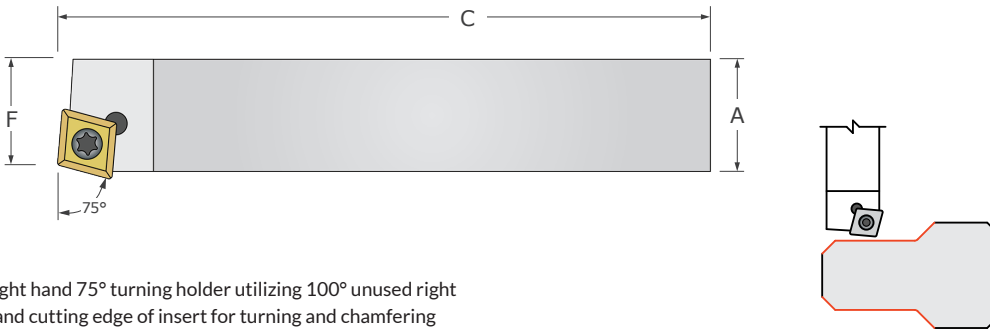

- Right hand 75° turning holder utilizing 100° unused right hand cutting edge of insert for turning and chamfering
- Made from precision ground heat treated steel
- Insert not included

Locating Offset	Square Shank	Overall Length	Insert Part Number	Holder Nomenclature	Tool Holder	
					Tool #	Price
F	A	C				
.267	.2500	2.4	50-1100	SCBCR 0404 D2	10-3151	37.30
.267	.3125	2.4	50-1100	SCBCR 0505 D2	10-3153	40.45
.330	.3750	2.8	50-1100	SCBCR 0606 E2	10-3155	45.45
.460	.5000	3.2	50-1100	SCBCR 0808 F2	10-3157	49.70
.574	.6250	4.0	50-1100	SCBCR 1010 H2	10-3159	55.10

## Indexable – Tool Holders

Profiling – Style SDNCN

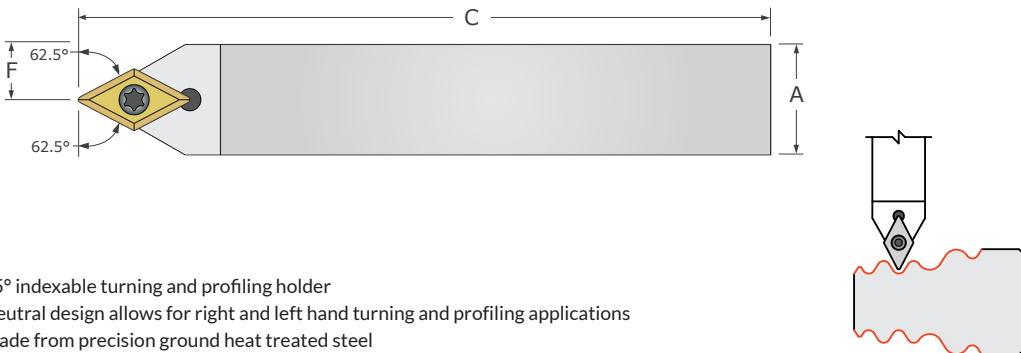

- 55° indexable turning and profiling holder
- Neutral design allows for right and left hand turning and profiling applications
- Made from precision ground heat treated steel
- Insert not included

Locating Offset	Square Shank	Overall Length	Insert Part Number	Holder Nomenclature	Tool Holder	
					Tool #	Price
F	A	C				
.157	.3125	3.9	50-1200	SDNCN 0505 H2	10-3761	45.45
.189	.3750	3.9	50-1200	SDNCN 0606 H2	10-3762	53.20
.250	.5000	3.9	50-1200	SDNCN 0808 H2	10-3763	56.00
.313	.6250	3.9	50-1200	SDNCN 1010 H2	10-3764	62.15

See pg 283 for indexable insert accessories

See pgs 277-282 for tool set options

## BT

## Brazed – Box Turning Tools

## BT Style

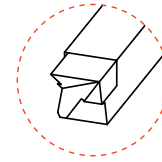
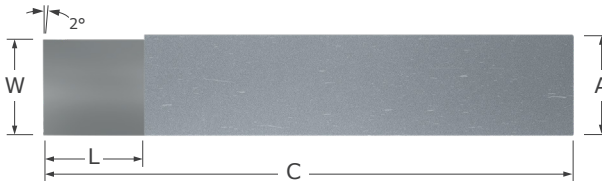

- Designed to be used for outside diameter (OD) turning with roller box turning attachments in automatic screw machines and turret lathes
- Ground to provide high metal removal rates improved finish and concentricity, when used in conjunction with a properly adjusted roller box turning attachment
- Hardened zinc coated shanks provide durability and corrosion resistance
- Available in industry standard fractional shank sizes ■ Ground in the USA

Width	Length	Square Shank	Overall Length	BT Style	
$W \begin{smallmatrix} +.040'' \\ -.000'' \end{smallmatrix}$	L	$A \begin{smallmatrix} +.0000'' \\ -.0100'' \end{smallmatrix}$	C	Tool #	Price
.200	.185	.2500	1.50	BT-4	26.90
.263	.185	.3125	1.75	BT-5	28.50
.325	.310	.3750	2.00	BT-6	29.90
.388	.310	.4375	2.25	BT-7	35.40
.450	.375	.5000	2.50	BT-8	33.50
.513	.375	.5625	2.75	BT-9	59.70
.575	.500	.6250	3.00	BT-10	39.80

## BTL

## Brazed – Box Turning Tools

## BTL Style

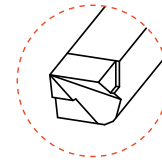
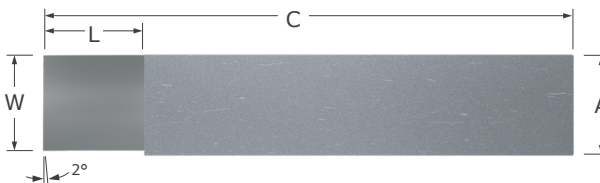

- Designed to be used for left hand outside diameter (OD) turning with roller box turning attachments in automatic screw machines and turret lathes
- Ground to provide high metal removal rates, improved finish, and concentricity when used in conjunction with a properly adjusted roller box turning attachment
- Hardened zinc coated shanks provide durability and corrosion resistance
- Available in industry standard fractional shank sizes ■ Ground in the USA

Width	Length	Square Shank	Overall Length	BTL Style	
$W \begin{smallmatrix} +.040'' \\ -.000'' \end{smallmatrix}$	L	$A \begin{smallmatrix} +.0000'' \\ -.0100'' \end{smallmatrix}$	C	Tool #	Price
.200	.185	.2500	1.50	BTL-4	47.70
.263	.185	.3125	1.75	BTL-5	47.80
.325	.310	.3750	2.00	BTL-6	49.70
.388	.310	.4375	2.25	BTL-7	50.20
.450	.375	.5000	2.50	BTL-8	37.30
.513	.375	.5625	2.75	BTL-9	59.70
.575	.500	.6250	3.00	BTL-10	63.70

## Brazed – Forming Tools

AR

AR Style

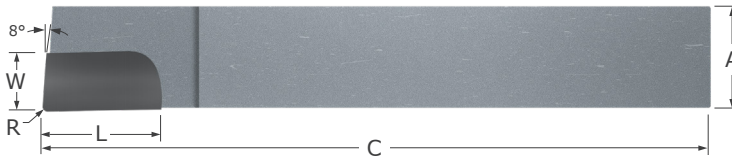

- Designed for right hand turning and facing in lathe applications
- Ground with side rake to provide a positive cutting action and better chip evacuation
- Corner radius profile
- Hardened zinc coated shanks provide durability and corrosion resistance
- Available in industry standard fractional shank sizes ■ Ground in the USA

Radius	Width	Length	Square Shank	Overall Length	AR Style	
R	W	L	A <sup>+0.0000"</sup> <sub>-.0050"</sub>	C	Tool #	Price
.015	.170	.250	.2500	2.00	AR-4	9.70
.015	.233	.313	.3125	2.25	AR-5	9.80
.015	.235	.500	.3750	2.50	AR-6	10.50
.015	.233	.500	.4375	3.00	AR-7	11.00
.015	.235	.625	.5000	3.50	AR-8	11.40
.015	.360	.750	.6250	4.00	AR-10	20.30
.015	.420	.813	.7500	4.50	AR-12	28.30

## Brazed – Forming Tools

AL

AL Style

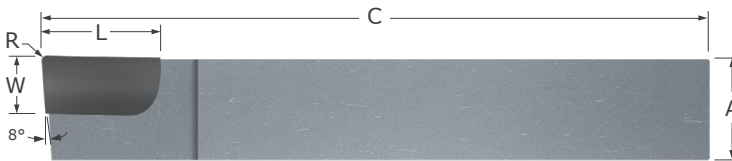

- Designed for left hand turning and facing on the outside diameter (OD) in lathe applications
- Ground with side rake to provide a positive cutting action and better chip evacuation
- Corner radius profile
- Hardened zinc coated shanks provide durability and corrosion resistance
- Available in industry standard fractional shank sizes ■ Ground in the USA

Radius	Width	Length	Square Shank	Overall Length	AL Style	
R	W	L	A <sup>+0.0000"</sup> <sub>-.0050"</sub>	C	Tool #	Price
.015	.170	.250	.2500	2.00	AL-4	9.70
.015	.233	.313	.3125	2.25	AL-5	9.80
.015	.235	.500	.3750	2.50	AL-6	10.50
.015	.233	.500	.4375	3.00	AL-7	11.00
.015	.235	.625	.5000	3.50	AL-8	11.40
.015	.360	.750	.6250	4.00	AL-10	20.30
.015	.420	.813	.7500	4.50	AL-12	28.30

Brazed

## BR

## Brazed – Forming Tools

## BR Style

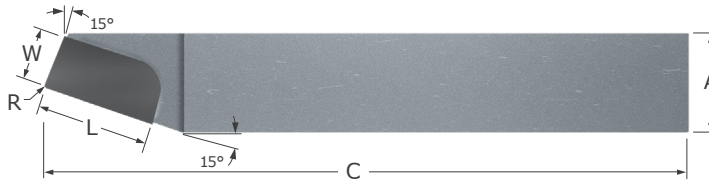

- Designed with a 15° side cutting edge angle for right hand turning in lathe applications
- Ground with side rake to provide a positive cutting action and better chip evacuation
- Side cutting edge angle allow for higher feed rates
- Corner radius profile
- Zinc coated shanks provide durability and corrosion resistance
- Available in industry standard fractional shank sizes
- Ground in the USA

Radius	Width	Length	Square Shank	Overall Length	BR Style	
R	W	L	A $\begin{smallmatrix} +.0000'' \\ -.0050'' \end{smallmatrix}$	C	Tool #	Price
.015	.250	.500	.3750	2.5	BR-6	10.70
.015	.250	.500	.4375	3.0	BR-7	11.20
.015	.250	.625	.5000	3.5	BR-8	12.00
.015	.375	.750	.6250	4.0	BR-10	21.40
.015	.438	.813	.7500	4.5	BR-12	29.60

## BL

## Brazed – Forming Tools

## BL Style

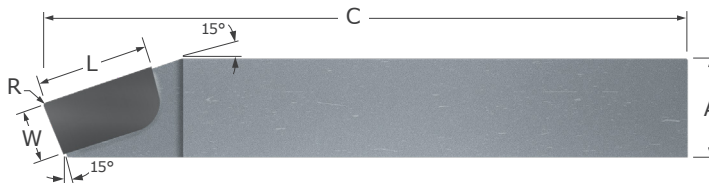

- Designed with a 15° side cutting edge angle for right hand turning in lathe applications
- Ground with side rake to provide a positive cutting action and better chip evacuation
- Side cutting edge angle allow for higher feed rates
- Corner radius profile
- Zinc coated shanks provide durability and corrosion resistance
- Available in industry standard fractional shank sizes
- Ground in the USA

Radius	Width	Length	Square Shank	Overall Length	BL Style	
R	W	L	A $\begin{smallmatrix} +.0000'' \\ -.0050'' \end{smallmatrix}$	C	Tool #	Price
.015	.250	.500	.3750	2.5	BL-6	10.70
.015	.250	.500	.4375	3.0	BL-7	11.20
.015	.250	.625	.5000	3.5	BL-8	12.00
.015	.375	.750	.6250	4.0	BL-10	21.40
.015	.438	.813	.7500	4.5	BL-12	29.60

# Brazed – Forming Tools

C

## C Style

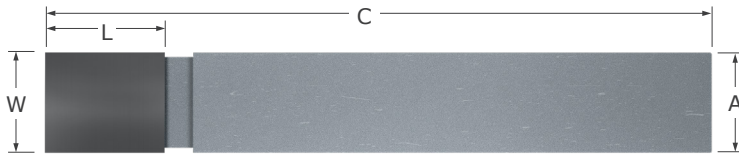

- Neutral design allows for right and left hand modifications
- First choice when modifying or making specials
- Zinc coated shanks provide durability and corrosion resistance
- Available in industry standard fractional shank sizes
- Ground in the USA

Width	Length	Square Shank	Overall Length	C Style	
				Tool #	Price
W	L	A $\begin{matrix} +.0000'' \\ -.0050'' \end{matrix}$	C		
.235	.250	.2500	6.00	C-250	26.90
.235	.250	.2500	2.00	C-4	10.10
.281	.375	.2812	6.00	C-281	40.80
.312	.375	.3125	6.00	C-312	22.60
.313	.375	.3125	2.25	C-5	10.90
.375	.500	.3750	2.50	C-6	11.20
.375	.500	.3750	6.00	C-375	18.80
.437	.500	.4375	6.00	C-437	33.90
.438	.500	.4375	3.00	C-7	11.40
.500	.500	.5000	3.50	C-8	11.60
.500	.500	.5000	6.00	C-500	23.00
.625	.625	.6250	4.00	C-10	25.10
.750	.750	.7500	4.00	C-750	49.20
.750	.750	.7500	4.50	C-12	29.50

Brazed

CRT

**Brazed – Forming Tools**  
 CRT Style – Full Radius (Concave)

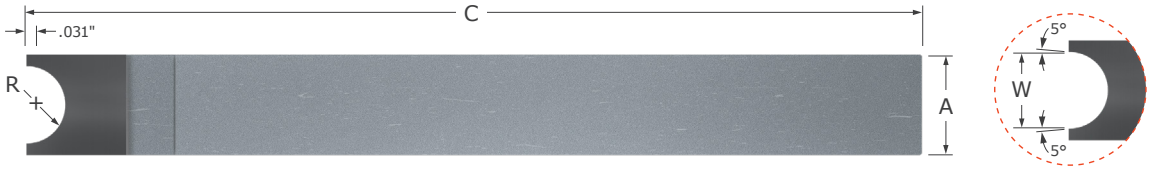

- Designed for forming a convex radius on the outside diameter (OD) of a part
- Zinc coated shanks provide durability and corrosion resistance
- Available in industry standard fractional shank sizes
- Ground in the USA

Radius	Width	Square Shank	Overall Length	CRT Style	
				Tool #	Price
R $\begin{matrix} +.0005'' \\ -.0005'' \end{matrix}$	W $\begin{matrix} +.004'' \\ -.004'' \end{matrix}$	A $\begin{matrix} +.0000'' \\ -.0050'' \end{matrix}$	C		
.0312	.067	.3750	2.5	CRT-1	44.20
.0625	.129	.3750	2.5	CRT-2	44.20
.0938	.192	.3750	2.5	CRT-3	44.20
.1250	.254	.5000	3.5	CRT-4	50.80
.1875	.379	.5000	3.5	CRT-6	54.70
.2500	.504	.7500	4.5	CRT-8	79.80

Brazed

# Brazed – Forming Tools

D

## D Style

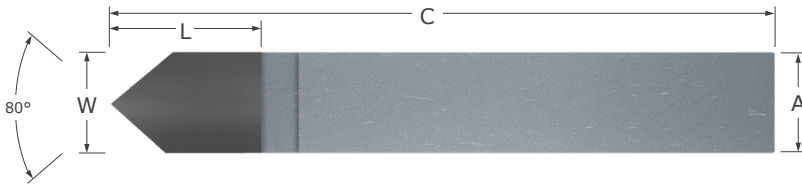

- Designed as a multi-functional tool for a manual lathe
- Zinc coated shanks provide durability and corrosion resistance
- Available in industry standard fractional shank sizes
- Ground in the USA

Width	Length	Square Shank	Overall Length	D Style	
W	L	A <sup>+0.000"</sup> <sub>-.0030"</sub>	C	Tool #	Price
.2500	.313	.2500	2.00	D-4	9.60
.3125	.375	.3125	2.25	D-5	11.10
.3750	.500	.3750	2.50	D-6	10.60
.4375	.500	.4375	3.00	D-7	11.60
.5000	.500	.5000	3.50	D-8	11.10
.6250	.625	.6250	4.00	D-10	20.60
.7500	.725	.7500	4.50	D-12	27.40



## RXD

## Brazed – Forming Tools

### 90° Radius Convex – Right Hand

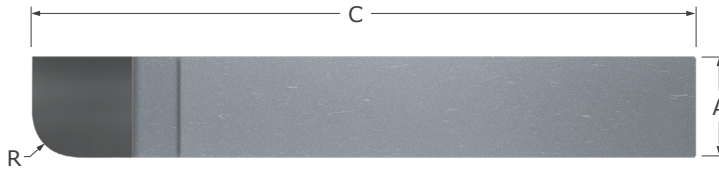

- Designed for forming a concave radius
- Zinc coated shanks provide durability and corrosion resistance
- Available in industry standard fractional shank sizes
- Ground in the USA

Radius	Square Shank	Overall Length	Brazed	
			Tool #	Price
$R \begin{matrix} +.0005'' \\ -.0005'' \end{matrix}$	$A \begin{matrix} +.0000'' \\ -.0050'' \end{matrix}$	C		
.0312	.3750	2.5	RXD-1	43.60
.0625	.3750	2.5	RXD-2	43.60
.0938	.3750	2.5	RXD-3	43.60
.1250	.3750	2.5	RXD-4	43.60
.1562	.3750	2.5	RXD-5	43.60
.1875	.3750	2.5	RXD-6	43.60
.2188	.3750	2.5	RXD-7	43.60
.2500	.3750	2.5	RXD-8	43.60
.2812	.5000	3.5	RXD-9	47.50
.3125	.5000	3.5	RXD-10	47.50
.3438	.5000	3.5	RXD-11	47.50
.3750	.5000	3.5	RXD-12	47.50
.4062	.7500	4.5	RXD-13	53.50
.4375	.7500	4.5	RXD-14	53.50
.4688	.7500	4.5	RXD-15	53.50
.5000	.7500	4.5	RXD-16	53.50

# Brazed – Forming Tools

RXL

## 90° Radius Convex – Left Hand

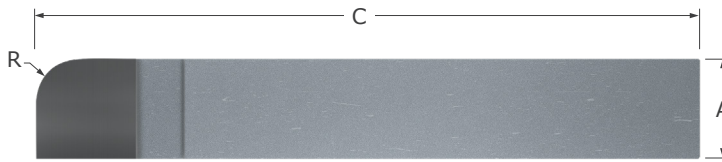

- Designed for forming a concave radius
- Zinc coated shanks provide durability and corrosion resistance
- Available in industry standard fractional shank sizes
- Ground in the USA

Radius	Square Shank	Overall Length	Brazed	
			Tool #	Price
$R \begin{matrix} +.0005'' \\ -.0005'' \end{matrix}$	$A \begin{matrix} +.0000'' \\ -.0050'' \end{matrix}$	C		
.0312	.3750	2.5	RXL-1	43.60
.0625	.3750	2.5	RXL-2	43.60
.0938	.3750	2.5	RXL-3	43.60
.1250	.3750	2.5	RXL-4	43.60
.1562	.3750	2.5	RXL-5	43.60
.1875	.3750	2.5	RXL-6	43.60
.2188	.3750	2.5	RXL-7	43.60
.2500	.3750	2.5	RXL-8	43.60
.2812	.5000	3.5	RXL-9	47.50
.3125	.5000	3.5	RXL-10	54.50
.3438	.5000	3.5	RXL-11	54.50
.3750	.5000	3.5	RXL-12	54.50
.4062	.7500	4.5	RXL-13	53.50
.4375	.7500	4.5	RXL-14	53.50
.4688	.7500	4.5	RXL-15	53.50
.5000	.7500	4.5	RXL-16	53.50

Brazed

## RAD

## Brazed – Forming Tools

### 90° Radius Concave – Right Hand

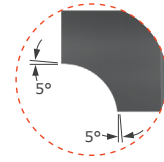
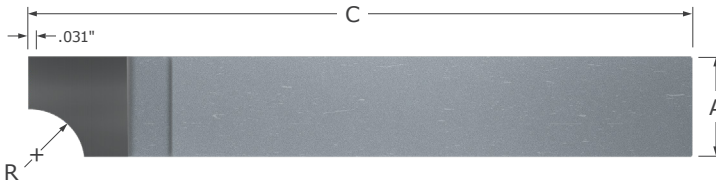

- Right hand tool designed for forming a convex radius
- Tangential 5° blend angles aid in providing a burr-free transition
- Zinc coated shanks provide durability and corrosion resistance
- Available in industry standard fractional shank sizes
- Ground in the USA

Radius	Square Shank	Overall Length	Brazed	
			Tool #	Price
$R \begin{matrix} +.0005'' \\ -.0005'' \end{matrix}$	$A \begin{matrix} +.0000'' \\ -.0050'' \end{matrix}$	C		
.0312	.3750	2.5	RAD-1	43.60
.0625	.3750	2.5	RAD-2	43.60
.0938	.3750	2.5	RAD-3	43.60
.1250	.3750	2.5	RAD-4	43.60
.1562	.3750	2.5	RAD-5	43.60
.1875	.3750	2.5	RAD-6	43.60
.2188	.3750	2.5	RAD-7	43.60
.2500	.3750	2.5	RAD-8	43.60
.2812	.5000	3.5	RAD-9	47.50
.3125	.5000	3.5	RAD-10	47.50
.3438	.5000	3.5	RAD-11	47.50
.3750	.5000	3.5	RAD-12	47.50
.4062	.7500	4.5	RAD-13	53.50
.4375	.7500	4.5	RAD-14	53.50
.4688	.7500	4.5	RAD-15	53.50
.5000	.7500	4.5	RAD-16	53.50

See pg 275 for tool set options

## Brazed – Forming Tools

RAL

### 90° Radius Concave – Left Hand



- Left hand tool designed for forming a convex radius
- Tangential 5° blend angles
- Zinc coated shanks provide durability and corrosion resistance
- Available in industry standard fractional shank sizes
- Ground in the USA

Radius	Square Shank	Overall Length	Brazed	
			Tool #	Price
$R \begin{matrix} +.0005'' \\ -.0005'' \end{matrix}$	$A \begin{matrix} +.0000'' \\ -.0050'' \end{matrix}$	C		
.0312	.3750	2.5	RAL-1	43.60
.0625	.3750	2.5	RAL-2	43.60
.0938	.3750	2.5	RAL-3	43.60
.1250	.3750	2.5	RAL-4	43.60
.1562	.3750	2.5	RAL-5	43.60
.1875	.3750	2.5	RAL-6	43.60
.2188	.3750	2.5	RAL-7	43.60
.2500	.3750	2.5	RAL-8	43.60
.2812	.5000	3.5	RAL-9	47.50
.3125	.5000	3.5	RAL-10	47.50
.3438	.5000	3.5	RAL-11	47.50
.3750	.5000	3.5	RAL-12	47.50
.4062	.7500	4.5	RAL-13	53.50
.4375	.7500	4.5	RAL-14	53.50
.4688	.7500	4.5	RAL-15	53.50
.5000	.7500	4.5	RAL-16	53.50

See pg 276 for tool set options

## TRG

## Brazed – Forming Tools

## Round Shank

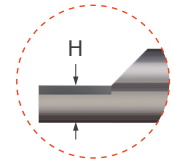
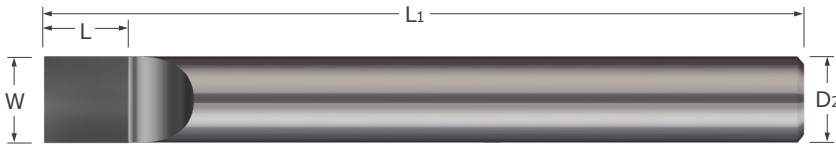

- Carbide tipped design allows for modification into a round shank special
- Carbide is mounted .031" above centerline to allow for grinding
- Neutral design allows for right and left hand modifications
- Hardened zinc coated shanks provide durability and corrosion resistance
- Available in industry standard fractional shank sizes ■ Ground in the USA

Width	Length	Split Height	Shank Diameter	Overall Length	Brazed	
W $\begin{matrix} +.0000" \\ -.0050" \end{matrix}$	L $\begin{matrix} +.031" \\ -.031" \end{matrix}$	H $\begin{matrix} +.000" \\ -.010" \end{matrix}$	D2 $\begin{matrix} +.0000" \\ -.0030" \end{matrix}$	L1	Tool #	Price
.2500	.253	.156	.2500	2.5	TRG-4	24.50
.3125	.375	.187	.3125	3.0	TRG-5	26.10
.3750	.500	.219	.3750	3.5	TRG-6	28.30
.4375	.500	.250	.4375	4.0	TRG-7	30.70
.5000	.500	.281	.5000	5.0	TRG-8	30.70
.6250	.625	.344	.6250	6.0	TRG-10	38.50

## FRT

## Brazed – Grooving Tools

## FRT Style – Full Radius (Convex)

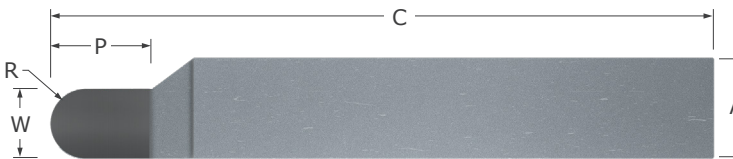

- Designed for generating a concave radius on the outside diameter (OD) of a part
- Available in industry standard shank sizes
- Ground in the USA

Radius	Width	Projection	Square Shank	Overall Length	Brazed	
R $\begin{matrix} +.0005" \\ -.0005" \end{matrix}$	W $\begin{matrix} +.001" \\ -.001" \end{matrix}$	P $\begin{matrix} +.015" \\ -.015" \end{matrix}$	A $\begin{matrix} +.0000" \\ -.0050" \end{matrix}$	C	Tool #	Price
.0312	.063	1.000	.3750	2.5	FRT-1	44.20
R $\begin{matrix} +.0005" \\ -.0005" \end{matrix}$	W $\begin{matrix} +.001" \\ -.001" \end{matrix}$	P $\begin{matrix} +.031" \\ -.031" \end{matrix}$	A $\begin{matrix} +.0000" \\ -.0050" \end{matrix}$	C	Tool #	Price
.0625	.125	.375	.3750	2.5	FRT-2	44.20
.0938	.188	.375	.3750	2.5	FRT-3	44.20
.1250	.250	.375	.3750	2.5	FRT-4	44.20
.1563	.313	.375	.3750	2.5	FRT-5	44.20
.1875	.375	.500	.5000	3.5	FRT-6	54.70
.2500	.500	.500	.5000	3.5	FRT-8	54.70
.3125	.625	.625	.6250	4.0	FRT-10	72.80
.3750	.750	.750	.7500	4.5	FRT-12	79.80

# Brazed – Grooving Tools

GR

## GR Style – Square

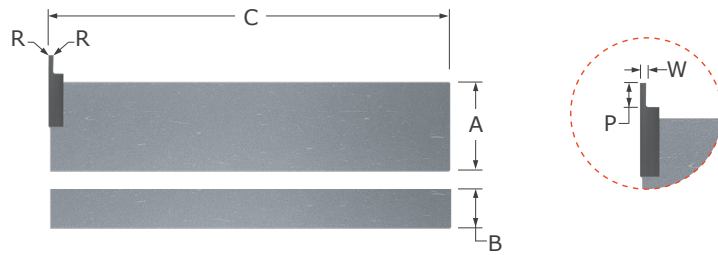

- Designed for plunging outside diameter (OD) grooves when the tool is held parallel to the axis
- Square profile with .003" corner radius for added strength
- Zinc coated shanks provide durability and corrosion resistance
- Available in industry standard fractional shank sizes
- Ground in the USA

Width	Projection	Radius	Shank Width	Shank Height	Overall Length	GR Style	
W $\begin{smallmatrix} +.002'' \\ -.000'' \end{smallmatrix}$	P $\begin{smallmatrix} +.000'' \\ -.030'' \end{smallmatrix}$	R (max)	A $\begin{smallmatrix} +.0000'' \\ -.0050'' \end{smallmatrix}$	B $\begin{smallmatrix} +.0000'' \\ -.0050'' \end{smallmatrix}$	C	Tool #	Price
.012	.030	.003	.7500	.3750	4.0	GR-012002	40.50
.018	.060	.003	.7500	.3750	4.0	GR-018002	40.50
.022	.090	.003	.7500	.3750	4.0	GR-022002	40.50
.028	.090	.003	.7500	.3750	4.0	GR-028002	40.50
.038	.120	.003	.7500	.3750	4.0	GR-038002	40.50
.040	.150	.003	.7500	.3750	4.0	GR-040002	40.50
.046	.150	.003	.7500	.3750	4.0	GR-046002	40.50
.054	.180	.003	.7500	.3750	4.0	GR-054002	40.50
.060	.210	.003	.7500	.3750	4.0	GR-060002	40.50
.068	.210	.003	.7500	.3750	4.0	GR-068002	40.50
.072	.240	.003	.7500	.3750	4.0	GR-072002	40.50
.080	.270	.003	.7500	.3750	4.0	GR-080002	40.50
.086	.270	.003	.7500	.3750	4.0	GR-086002	40.50
.090	.300	.003	.7500	.3750	4.0	GR-090002	40.50
.096	.300	.003	.7500	.3750	4.0	GR-096002	40.50
.102	.400	.003	.7500	.3750	4.0	GR-102002	40.50
.114	.400	.003	.7500	.3750	4.0	GR-114002	40.50
.120	.400	.003	.7500	.3750	4.0	GR-120002	40.50
.122	.400	.003	.7500	.3750	4.0	GR-122002	40.50

Brazed

## GR-F

## Brazed – Grooving Tools

## GR Style – Full Radius

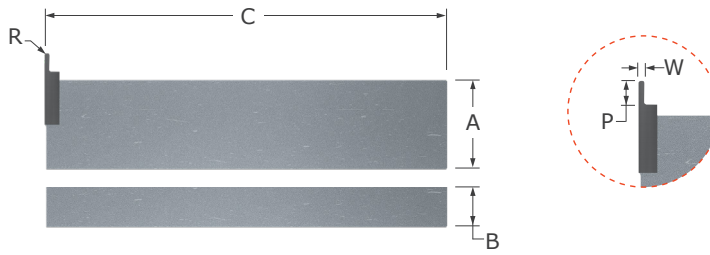

- Designed for plunging full radius outside diameter (OD) grooves when the tool is held parallel to the axis
- Zinc coated shanks provide durability and corrosion resistance
- Available in industry standard fractional shank sizes
- Ground in the USA

Radius	Width	Projection	Shank Width	Shank Height	Overall Length	GR-F Style	
R $\begin{matrix} +.001" \\ -.000" \end{matrix}$	W $\begin{matrix} +.002" \\ -.000" \end{matrix}$	P $\begin{matrix} +.000" \\ -.030" \end{matrix}$	A $\begin{matrix} +.0000" \\ -.0050" \end{matrix}$	B $\begin{matrix} +.0000" \\ -.0050" \end{matrix}$	C	Tool #	Price
.006	.012	.030	.7500	.3750	4.0	GR-012F	42.20
.009	.018	.060	.7500	.3750	4.0	GR-018F	42.20
.011	.022	.090	.7500	.3750	4.0	GR-022F	42.20
.014	.028	.090	.7500	.3750	4.0	GR-028F	42.20
.019	.038	.120	.7500	.3750	4.0	GR-038F	42.20
.020	.040	.150	.7500	.3750	4.0	GR-040F	42.20
.023	.046	.150	.7500	.3750	4.0	GR-046F	42.20
.027	.054	.180	.7500	.3750	4.0	GR-054F	42.20
.030	.060	.210	.7500	.3750	4.0	GR-060F	42.20
.034	.068	.210	.7500	.3750	4.0	GR-068F	42.20
.036	.072	.240	.7500	.3750	4.0	GR-072F	42.20
.040	.080	.270	.7500	.3750	4.0	GR-080F	42.20
.043	.086	.270	.7500	.3750	4.0	GR-086F	42.20
.045	.090	.300	.7500	.3750	4.0	GR-090F	42.20
.048	.096	.300	.7500	.3750	4.0	GR-096F	42.20
.051	.102	.400	.7500	.3750	4.0	GR-102F	42.20
.057	.114	.400	.7500	.3750	4.0	GR-114F	42.20
.060	.120	.400	.7500	.3750	4.0	GR-120F	42.20
.061	.122	.400	.7500	.3750	4.0	GR-122F	42.20

# Brazed – Grooving Tools

GS

## GS Style – Square

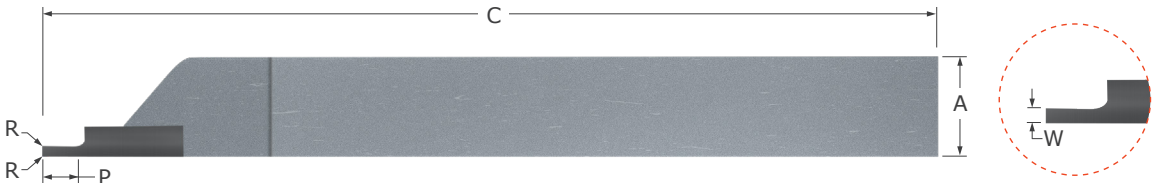

- Designed for plunging grooves when on the outside diameter of a part
- Square profile with .003" corner radius for added strength
- Zinc coated shanks provide durability and corrosion resistance
- Available in industry standard fractional shank sizes
- Ground in the USA

Width	Projection	Radius	Square Shank	Overall Length	GS Style	
W $\begin{smallmatrix} +.002" \\ -.000" \end{smallmatrix}$	P $\begin{smallmatrix} +.000" \\ -.030" \end{smallmatrix}$	R (max)	A $\begin{smallmatrix} +.0000" \\ -.0050" \end{smallmatrix}$	C	Tool #	Price
.012	.030	.003	.3750	3.0	GS-012002	32.90
.018	.060	.003	.3750	3.0	GS-018002	32.90
.022	.090	.003	.3750	3.0	GS-022002	32.90
.028	.090	.003	.3750	3.0	GS-028002	32.90
.038	.120	.003	.3750	3.0	GS-038002	32.90
.040	.150	.003	.3750	3.0	GS-040002	32.90
.046	.150	.003	.3750	3.0	GS-046002	32.90
.054	.180	.003	.3750	3.0	GS-054002	32.90
.060	.210	.003	.3750	3.0	GS-060002	32.90
.068	.210	.003	.3750	3.0	GS-068002	32.90
.072	.240	.003	.3750	3.0	GS-072002	32.90
.080	.270	.003	.3750	3.0	GS-080002	32.90
.086	.270	.003	.3750	3.0	GS-086002	32.90
.090	.300	.003	.3750	3.0	GS-090002	32.90
.096	.300	.003	.3750	3.0	GS-096002	32.90
.102	.400	.003	.3750	3.0	GS-102002	32.90
.114	.400	.003	.3750	3.0	GS-114002	32.90
.120	.400	.003	.3750	3.0	GS-120002	32.90
.122	.400	.003	.3750	3.0	GS-122002	32.90

Brazed



## GS-F

## Brazed – Grooving Tools

## GS Style – Full Radius

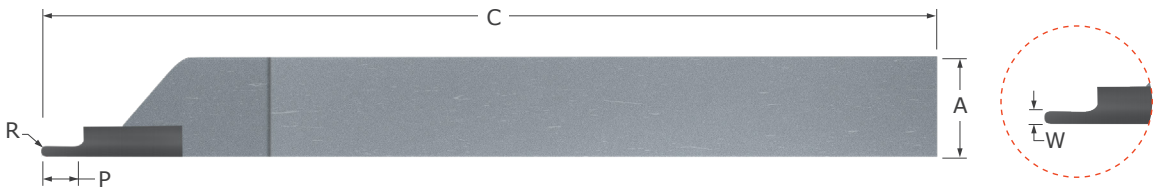

- Designed for generating full radius outside diameter (OD) grooves
- Zinc coated shanks provide durability and corrosion resistance
- Available in industry standard fractional shank sizes
- Ground in the USA

Radius	Width	Projection	Square Shank	Overall Length	GS-F Style	
R $+0.001''$ $-0.000''$	W $+0.002''$ $-0.000''$	P $+0.000''$ $-0.030''$	A $+0.0000''$ $-0.0050''$	C	Tool #	Price
.006	.012	.030	.3750	3.0	GS-012F	36.40
.009	.018	.060	.3750	3.0	GS-018F	36.40
.011	.022	.090	.3750	3.0	GS-022F	36.40
.014	.028	.090	.3750	3.0	GS-028F	36.40
.019	.038	.120	.3750	3.0	GS-038F	36.40
.020	.040	.150	.3750	3.0	GS-040F	36.40
.023	.046	.150	.3750	3.0	GS-046F	36.40
.027	.054	.180	.3750	3.0	GS-054F	36.40
.030	.060	.210	.3750	3.0	GS-060F	36.40
.034	.068	.210	.3750	3.0	GS-068F	36.40
.036	.072	.240	.3750	3.0	GS-072F	36.40
.040	.080	.270	.3750	3.0	GS-080F	36.40
.043	.086	.270	.3750	3.0	GS-086F	36.40
.045	.090	.300	.3750	3.0	GS-090F	36.40
.048	.096	.300	.3750	3.0	GS-096F	36.40
.051	.102	.400	.3750	3.0	GS-102F	36.40
.057	.114	.400	.3750	3.0	GS-114F	36.40
.060	.120	.400	.3750	3.0	GS-120F	36.40
.061	.122	.400	.3750	3.0	GS-122F	36.40

# Brazed – Threading Tools

E

## E Style

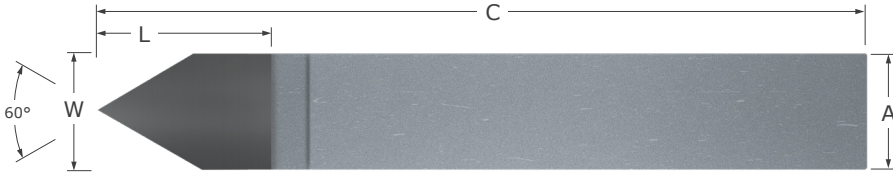

- Designed for outside diameter (OD) general purpose threading
- Neutral design allows for right and left hand threading applications
- Zinc coated shanks provide durability and corrosion resistance
- Available in industry standard fractional shank sizes
- Ground in the USA

Width	Length	Square Shank	Overall Length	E Style	
W	L	A <sup>+0.000"</sup> <sub>-.0050"</sub>	C	Tool #	Price
.3125	.363	.3125	2.25	E-5	10.50
.3750	.568	.3750	2.50	E-6	10.50
.5000	.568	.5000	3.50	E-8	11.00
.6250	.653	.6250	4.00	E-10	20.90
.7500	.778	.7500	4.50	E-12	24.20

Brazed

## ER

## Brazed – Threading Tools

## ER Style

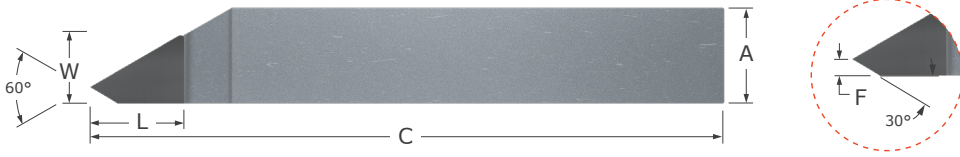

- Designed for right hand threading on the outside diameter (OD), close to a shoulder
- Zinc coated shanks provide durability and corrosion resistance
- Available in industry standard fractional shank sizes
- Ground in the USA

Point Offset	Width	Length	Square Shank	Overall Length	ER Style	
					Tool #	Price
$F \begin{matrix} +.010'' \\ -.010'' \end{matrix}$	W	L	$A \begin{matrix} +.0000'' \\ -.0050'' \end{matrix}$	C		
.063	.266	.360	.3750	2.50	ER-6	12.00
.063	.270	.360	.3125	2.25	ER-5	11.20
.094	.444	.610	.6250	4.00	ER-10	20.10
.094	.446	.610	.5000	3.50	ER-8	13.30
.125	.558	.750	.7500	4.50	ER-12	25.60

## EL

## Brazed – Threading Tools

## EL Style

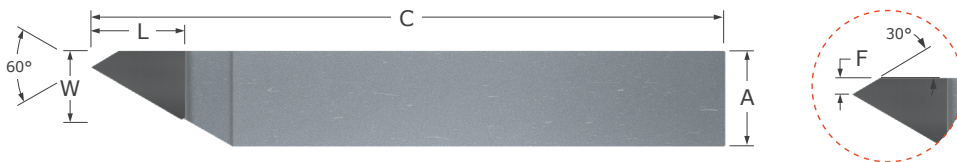

- Designed for left hand threading on the outside diameter (OD), close to a shoulder
- Zinc coated shanks provide durability and corrosion resistance
- Available in industry standard fractional shank sizes
- Ground in the USA

Point Offset	Width	Length	Square Shank	Overall Length	EL Style	
					Tool #	Price
$F \begin{matrix} +.010'' \\ -.010'' \end{matrix}$	W	L	$A \begin{matrix} +.0000'' \\ -.0050'' \end{matrix}$	C		
.063	.266	.360	.3750	2.50	EL-6	12.00
.063	.270	.360	.3125	2.25	EL-5	11.20
.094	.444	.610	.6250	4.00	EL-10	20.10
.094	.446	.610	.5000	3.50	EL-8	13.30
.125	.558	.750	.7500	4.50	EL-12	25.60

# Brazed – Screw Machining Tools

RT / LT

Turning

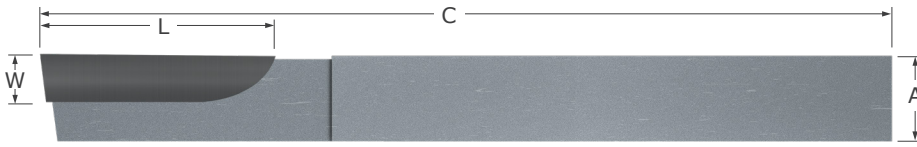

- Designed for general purpose turning; RT for right hand and LT for left hand
- Zinc coated shanks provide durability and corrosion resistance
- Available in industry standard fractional shank sizes
- Ground in the USA

Width	Length	Square Shank	Overall Length	Right Hand		Left Hand	
W	L	A $\begin{matrix} +.0000'' \\ -.0050'' \end{matrix}$	C	Tool #	Price	Tool #	Price
.128	1.075	.2500	6.0	RT-250	16.00	LT-250	32.00
.174	1.200	.2812	6.0	RT-281	16.70	LT-281	29.00
.188	1.200	.3750	6.0	RT-375	16.00	LT-375	32.00
.190	1.200	.3125	6.0	RT-312	15.80	LT-312	14.40
.253	1.345	.5000	6.0	RT-500	20.70	LT-500	25.70
.260	1.345	.4375	6.0	RT-437	20.30	LT-437	33.00
.263	1.345	.6250	4.0	RT-625	27.30	LT-625	27.30
.263	1.345	.7500	4.0	RT-750	32.00	LT-750	39.00

## RC / LC

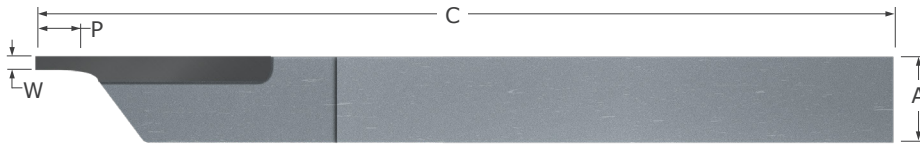
Brazed – Screw Machine Tools  
Cut Off

- Designed for cut off applications; RC for right hand and LC for left hand
- Zinc coated shanks provide durability and corrosion resistance
- Available in industry standard fractional shank sizes
- Ground in the USA

Width	Projection	Square Shank	Overall Length	Right Hand		Left Hand	
W $\begin{smallmatrix} +.000'' \\ -.005'' \end{smallmatrix}$	P (min)	A $\begin{smallmatrix} +.0000'' \\ -.0050'' \end{smallmatrix}$	C	Tool #	Price	Tool #	Price
.040	.120	.2500	6.0	RC-250040	15.10	LC-250040	37.00
.040	.120	.2812	6.0	RC-281040	16.70	LC-281040	44.40
.040	.120	.3125	6.0	RC-312040	15.80	LC-312040	30.90
.040	.120	.3750	6.0	RC-375040	15.60	LC-375040	31.10
.060	.180	.2500	6.0	RC-250060	15.10	LC-250060	24.90
.060	.180	.2812	6.0	RC-281060	16.70	LC-281060	44.40
.060	.180	.3125	6.0	RC-312060	15.80	LC-312060	19.60
.060	.180	.3750	6.0	RC-375060	15.60	LC-375060	20.90
.060	.180	.4375	6.0	RC-437060	19.80	LC-437060	32.10
.060	.180	.5000	6.0	RC-500060	20.50	LC-500060	20.70
.060	.180	.6250	4.0	RC-625060	26.90	LC-625060	27.30
.060	.180	.7500	4.0	RC-750060	32.00	LC-750060	32.00
.080	.240	.2812	6.0	RC-281080	16.70	LC-281080	31.10
.080	.240	.3125	6.0	RC-312080	15.80	LC-312080	17.30
.080	.240	.3750	6.0	RC-375080	15.60	LC-375080	24.70
.080	.240	.4375	6.0	RC-437080	19.80	LC-437080	32.10
.080	.240	.5000	6.0	RC-500080	20.60	LC-500080	20.70
.080	.240	.6250	4.0	RC-625080	26.20	LC-625080	27.30
.080	.240	.7500	4.0	RC-750080	32.00	LC-750080	32.00
.100	.300	.2812	6.0	RC-281100	16.70	LC-281100	22.60
.100	.300	.3125	6.0	RC-312100	15.80	LC-312100	17.30
.100	.300	.3750	6.0	RC-375100	15.60	LC-375100	22.80
.100	.300	.4375	6.0	RC-437100	20.20	LC-437100	34.10
.100	.300	.5000	6.0	RC-500100	20.60	LC-500100	20.70
.100	.300	.6250	4.0	RC-625100	27.30	LC-625100	27.30
.100	.300	.7500	4.0	RC-750100	32.00	LC-750100	32.00
.120	.360	.3750	6.0	RC-375120	15.60	LC-375120	28.50
.120	.360	.4375	6.0	RC-437120	20.20	LC-437120	33.00
.120	.360	.5000	6.0	RC-500120	20.30	LC-500120	20.70
.125	.375	.6250	4.0	RC-625125	27.30	LC-625125	27.30
.125	.375	.7500	4.0	RC-750125	32.00	LC-750125	32.00
.187	.561	.6250	4.0	RC-625187	32.00	LC-625187	27.30
.187	.561	.7500	4.0	RC-750187	34.00	LC-750187	32.00

# Brazed – Cut Off Tools

CR

CR Style

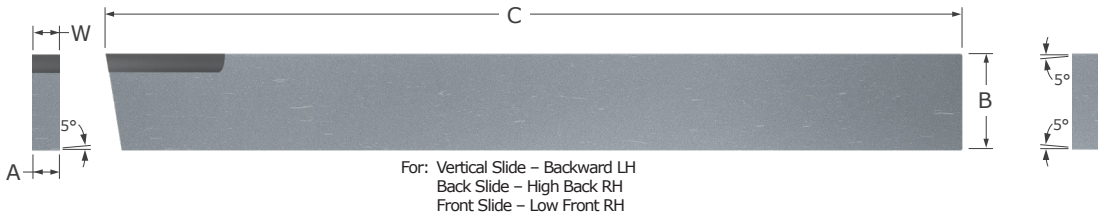

- Right hand cut-off blades for Brown & Sharpe automatic screw machines
- Designed for use in Pratt & Whitney holders and dovetail slot holders
- Hardened and precision ground steel blades
- Ground in the USA

Width	Shank Width	Shank Height	Overall Length	CR Style	
W $+0.0000''$ $-0.0050''$	A $+0.0000''$ $-0.0050''$	B $+0.0000''$ $-0.0050''$	C	Tool #	Price
.0781	.0580	.5000	4.5	CR-101	66.80
.0938	.0730	.5000	4.5	CR-102	52.40
.0938	.0730	.6875	5.0	CR-104	70.30
.0938	.0730	.8125	6.0	CR-108	71.60
.0938	.0730	1.0000	6.0	CR-113	101.70
.1250	.1050	.5000	4.5	CR-103	50.80
.1250	.1050	.6875	5.0	CR-105	70.30
.1250	.1050	.8125	6.0	CR-109	55.60
.1562	.1360	.6875	5.0	CR-106	74.30
.1562	.1360	.8125	6.0	CR-110	120.20
.1875	.1670	.6875	5.0	CR-107	77.40
.1875	.1670	.8125	6.0	CR-111	104.40

Brazed

## CL

## Brazed – Cut Off Tools

## CL Style

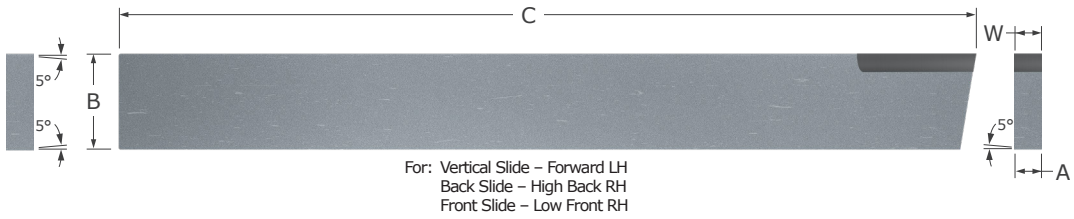

- Left hand cut-off blades for Brown & Sharpe automatic screw machines
- Designed for use in Pratt & Whitney holders and dovetail slot holders
- Hardened and precision ground steel blades
- Ground in the USA

Width	Shank Width	Shank Height	Overall Length	CL Style	
				Tool #	Price
W $+.0000"$ $-.0050"$	A $+.0000"$ $-.0050"$	B $+.0000"$ $-.0050"$	C		
.0781	.0580	.5000	4.5	CL-101	67.10
.0938	.0730	.5000	4.5	CL-102	67.80
.0938	.0730	.6875	5.0	CL-104	79.00
.0938	.0730	.8125	6.0	CL-108	90.90
.0938	.0730	1.0000	6.0	CL-113	52.20
.1250	.1050	.5000	4.5	CL-103	69.40
.1250	.1050	.6875	5.0	CL-105	73.80
.1250	.1050	.8125	6.0	CL-109	76.40
.1250	.1050	1.0000	6.0	CL-114	52.20
.1562	.1360	.6875	5.0	CL-106	81.90
.1562	.1360	.8125	6.0	CL-110	98.10
.1875	.1670	.6875	5.0	CL-107	85.00
.1875	.1670	.8125	6.0	CL-111	43.90

# Brazed – Cut Off Tools

CT

CT Style

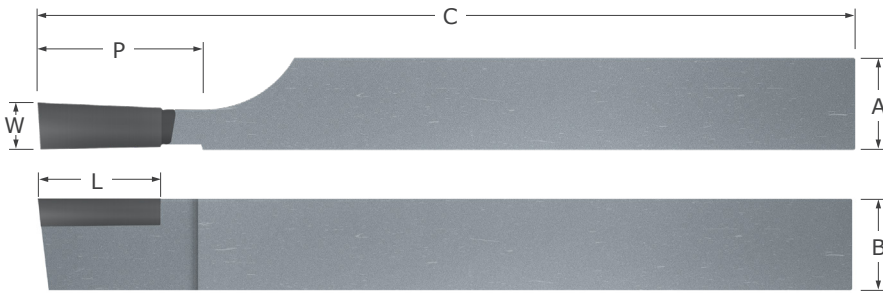

- Designed for cut-off with a 5° front clearance to reduce cut-off burr
- Hardened zinc coated shanks provide durability and corrosion resistance
- Available in industry standard fractional shank sizes
- Ground in the USA

Width	Projection	Length	Shank Width	Shank Height	Overall Length	CT Style	
W $^{+.000"}_{-.005"}"$	P $^{+.062"}_{-.000"}"$	L	A $^{+.0000"}_{-.0100"}"$	B $^{+.0000"}_{-.0100"}"$	C	Tool #	Price
.187	.813	.750	.5000	1.0000	5.0	CT-122	24.90
.250	1.000	.750	.5000	1.0000	5.0	CT-121	26.80
.312	1.000	.500	.5000	1.0000	5.0	CT-120	27.30
.375	1.250	.500	.6250	1.2500	5.0	CT-130	34.10
.375	1.250	.625	.7500	1.5000	6.0	CT-140	43.20

Brazed



## T

## Brazed – Cut Off Tools

## T Style – Regular

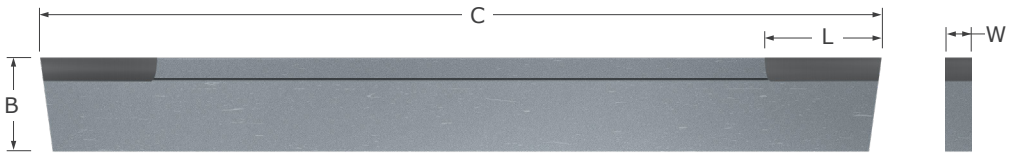

- Double end "T" style cut-off tool that is parallel ground to help achieve a straighter cut
- Tops are hollow ground to help curl the chip to center for better evacuation
- Hardened and precision ground steel blades
- Ground in the USA

Width	Length	Shank Height	Overall Length	T Style	
W $\begin{matrix} +.001" \\ -.001" \end{matrix}$	L	B	C	Tool #	Price
.062	.750	.5000	4.5	T-100	46.40
.078	.750	.5000	4.5	T-101	47.10
.093	.750	.5000	4.5	T-102	45.10
.093	.750	.6875	5.0	T-104	49.90
.125	.750	.5000	4.5	T-103	44.50
.125	.750	.6875	5.0	T-105	49.30
.125	.750	.7500	5.0	T-108	51.00
.125	.750	.8750	6.0	T-111	56.10
.156	.750	.6875	5.0	T-106	60.50
.156	.750	.7500	5.0	T-109	53.80
.156	.750	.8750	6.0	T-112	56.00
.187	.750	.6875	5.0	T-107	62.50
.187	.750	.7500	5.0	T-110	50.20
.187	.750	.8750	6.0	T-113	65.40
.187	.750	1.1250	6.0	T-116	67.80

# Brazed – Cut Off Tools

T-V

## T Style – V-Groove

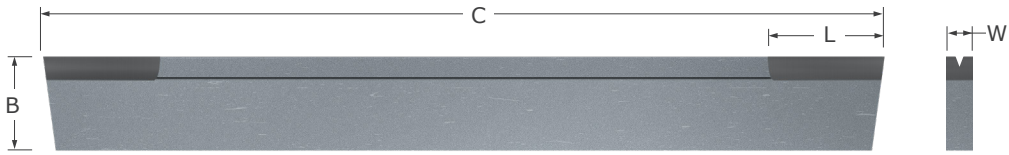

- Double ended "T" style cut-off tool that is parallel ground to help achieve a straighter cut
- Tops are hollow ground to help curl the chip to center for better evacuation
- Additional V-groove ground into the top of the tool forces the chip into a "W" form to pull the chip to center resulting in better surface finish and chip evacuation
- Hardened and precision ground steel blades
- Ground in the USA

Width	Length	Shank Height	Overall Length	Brazed Style	
				Tool #	Price
$W \begin{matrix} +.001" \\ -.001" \end{matrix}$	L	B	C		
.062	.760	.5000	4.5	T-100-V	53.00
.078	.760	.5000	4.5	T-101-V	59.20
.093	.760	.5000	4.5	T-102-V	52.60
.093	.760	.6875	5.0	T-104-V	56.40
.125	.750	.5000	4.5	T-103-V	51.50
.125	.760	.6875	5.0	T-105-V	55.30
.125	.750	.7500	5.0	T-108-V	58.90
.125	.750	.8750	6.0	T-111-V	63.30
.156	.750	.6875	5.0	T-106-V	66.50
.156	.750	.7500	5.0	T-109-V	59.80
.156	.750	.8750	6.0	T-112-V	68.40
.187	.750	.6875	5.0	T-107-V	68.50
.187	.750	.7500	5.0	T-110-V	59.70
.187	.750	.8750	6.0	T-113-V	71.40
.187	.750	1.1250	6.0	T-116-V	75.30

Brazed

# MILLING

## End Mills, Holemaking & Threading



<b>End Mills .....</b>	<b>156</b>
End Mills – Square .....	156
End Mills – Ball .....	170
End Mills – Corner Radius.....	179
<b>Material Specific End Mills.....</b>	<b>182</b>
End Mills for Hardened Steels.....	182
End Mills for Steels & High Temperature Alloys.....	183
End Mills for Aluminum Alloys.....	219
End Mills for Plastics & Composites .....	224
<b>Specialty Profiles .....</b>	<b>232</b>
Undercutting End Mills .....	232
Drill/End Mills .....	234
Chamfer Cutters.....	236
Runner Cutters.....	238
Engraving Cutters .....	239
Keyseat Cutters.....	243
Corner Rounding End Mills .....	246
Dovetail Cutters .....	248
Die Sink Cutters.....	249
<b>Indexable Milling .....</b>	<b>250</b>
<b>Holemaking &amp; Threading .....</b>	<b>252</b>
Drills.....	252
Combined Drill & Countersinks.....	255
Thread Milling Cutters.....	256

# End Mills – Square

## 2 Flute – Stub & Standard – Miniature

RME / RMEM  
SME / AMRM

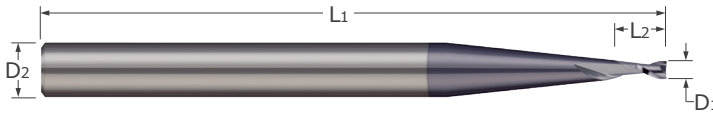

End Mills

- Designed for general purpose micromachining
- Cutter diameter down to .005"
- 30° helix ■ Center cutting ■ Square profile
- AlTiN coating option for added lubricity and increased wear resistance in difficult-to-machine materials
- Solid carbide ■ CNC ground in the USA

Cutter Diameter*			Length of Cut	Flutes	Shank Diameter	Overall Length	Uncoated		AlTiN Coated	
D1			L2		D2 (h6)	L1	Tool #	Price	Tool #	Price
+ .0005"	+ .00 mm	decimal equiv.	+ .010"							
- .0005"	- .02 mm		- .000"							
			+ .25 mm							
			- .00 mm							
.0050		.0050	.007	2	.1250	1.5	SME-005-2	43.40	SME-005-2X	45.90
.0060		.0060	.009	2	.1250	1.5	SME-006-2	43.40	SME-006-2X	45.90
.0070		.0070	.010	2	.1250	1.5	SME-007-2	36.80	SME-007-2X	39.30
	0.2 mm	.0079	0.4 mm	2	3 mm	38 mm	RMEM-002-2	30.60	RMEM-002-2X	33.10
	0.2 mm	.0079	0.4 mm	2	4 mm	50 mm	AMRM-002-2	33.20	AMRM-002-2X	36.10
.0080		.0080	.012	2	.1250	1.5	SME-008-2	36.80	SME-008-2X	39.30
.0090		.0090	.013	2	.1250	1.5	SME-009-2	33.45	SME-009-2X	35.95
.0100		.0100	.015	2	.1250	1.5	SME-010-2	33.45	SME-010-2X	35.95
.0100		.0100	.030	2	.1250	1.5	RME-010-2	34.95	RME-010-2X	37.45
.0110		.0110	.016	2	.1250	1.5	SME-011-2	30.25		
.0110		.0110	.033	2	.1250	1.5			RME-011-2X	34.15
	0.3 mm	.0118	0.9 mm	2	3 mm	38 mm	RMEM-003-2	26.35	RMEM-003-2X	28.85
	0.3 mm	.0118	0.9 mm	2	4 mm	50 mm	AMRM-003-2	29.00	AMRM-003-2X	31.90
.0120		.0120	.018	2	.1250	1.5	SME-012-2	30.25	SME-012-2X	32.75
.0120		.0120	.036	2	.1250	1.5	RME-012-2	31.65	RME-012-2X	34.15
.0130		.0130	.019	2	.1250	1.5	SME-013-2	25.70	SME-013-2X	28.20
.0130		.0130	.039	2	.1250	1.5	RME-013-2	26.90	RME-013-2X	29.40
.0140		.0140	.021	2	.1250	1.5	SME-014-2	25.70	SME-014-2X	28.20
.0140		.0140	.042	2	.1250	1.5	RME-014-2	26.90	RME-014-2X	29.40
.0150		.0150	.022	2	.1250	1.5	SME-015-2	20.45	SME-015-2X	22.95
.0150		.0150	.045	2	.1250	1.5	RME-015-2	21.35	RME-015-2X	23.85
	0.4 mm	.0157	1.2 mm	2	3 mm	38 mm	RMEM-004-2	19.35		
	0.4 mm	.0157	1.2 mm	2	4 mm	50 mm	AMRM-004-2	22.05	AMRM-004-2X	24.95
.0160		.0160	.024	2	.1250	1.5	SME-016-2	20.45	SME-016-2X	22.95
.0160		.0160	.048	2	.1250	1.5	RME-016-2	21.35	RME-016-2X	23.85
.0170		.0170	.025	2	.1250	1.5	SME-017-2	20.45	SME-017-2X	22.95
.0170		.0170	.051	2	.1250	1.5	RME-017-2	21.35	RME-017-2X	23.85
.0180		.0180	.027	2	.1250	1.5	SME-018-2	20.45	SME-018-2X	22.95
.0180		.0180	.054	2	.1250	1.5	RME-018-2	21.35	RME-018-2X	23.85
.0190		.0190	.028	2	.1250	1.5	SME-019-2	20.45	SME-019-2X	22.95
.0190		.0190	.057	2	.1250	1.5			RME-019-2X	23.85
	0.5 mm	.0197	1.5 mm	2	3 mm	38 mm	RMEM-005-2	17.85	RMEM-005-2X	20.35
	0.5 mm	.0197	1.5 mm	2	4 mm	50 mm	AMRM-005-2	19.30	AMRM-005-2X	22.20

\*.0005" / .013 mm max TIR

Continued on next page

RME / RMEM  
SME / AMRM

End Mills – Square

2 Flute – Stub & Standard – Miniature (cont.)

Continued from previous page

Cutter Diameter*			Length of Cut	Flutes	Shank Diameter	Overall Length	Uncoated		AlTiN Coated	
D1 +.0005" -.0005"	+.00 mm -.02 mm	decimal equiv.	L2 +.010" -.000" +.25 mm -.00 mm	2	D2 (h6)	L1	Tool #	Price	Tool #	Price
.0200	.0200	.0200	.060	.1250	1.5	RME-020-2	19.70	RME-020-2X	22.20	
.0210	.0210	.0210	.063	.1250	1.5	RME-021-2	19.70	RME-021-2X	22.20	
.0220	.0220	.0220	.033	.1250	1.5	SME-022-2	18.85	SME-022-2X	21.35	
.0220	.0220	.0220	.066	.1250	1.5	RME-022-2	19.70	RME-022-2X	22.20	
.0230	.0230	.0230	.034	.1250	1.5	SME-023-2	18.85	SME-023-2X	21.35	
.0230	.0230	.0230	.069	.1250	1.5	RME-023-2	19.70	RME-023-2X	22.20	
0.6 mm	.0236	.0236	1.8 mm	2	3 mm	38 mm	RMEM-006-2	17.85	RMEM-006-2X	20.35
.0240	.0240	.0240	.036	.1250	1.5	SME-024-2	18.85	SME-024-2X	21.35	
.0240	.0240	.0240	.072	.1250	1.5	RME-024-2	19.70	RME-024-2X	22.20	
.0250	.0250	.0250	.037	.1250	1.5	SME-025-2	18.85	SME-025-2X	21.35	
.0250	.0250	.0250	.075	.1250	1.5	RME-025-2	19.70	RME-025-2X	22.20	
.0260	.0260	.0260	.039	.1250	1.5	SME-026-2	16.55	SME-026-2X	19.05	
.0270	.0270	.0270	.040	.1250	1.5	SME-027-2	16.55	SME-027-2X	19.05	
.0270	.0270	.0270	.081	.1250	1.5	RME-027-2	16.65	RME-027-2X	19.15	
0.7 mm	.0276	.0276	2.1 mm	2	3 mm	38 mm	RMEM-007-2	16.00	RMEM-007-2X	18.50
0.7 mm	.0276	.0276	2.1 mm	2	4 mm	50 mm	AMRM-007-2	17.35	AMRM-007-2X	20.25
.0280	.0280	.0280	.042	.1250	1.5	SME-028-2	16.55	SME-028-2X	19.05	
.0280	.0280	.0280	.084	.1250	1.5	RME-028-2	16.65	RME-028-2X	19.15	
.0290	.0290	.0290	.043	.1250	1.5	SME-029-2	16.55	SME-029-2X	19.05	
.0290	.0290	.0290	.087	.1250	1.5	RME-029-2	16.65	RME-029-2X	19.15	
.0300	.0300	.0300	.045	.1250	1.5	SME-030-2	16.55	SME-030-2X	19.05	
.0300	.0300	.0300	.090	.1250	1.5	RME-030-2	16.65	RME-030-2X	19.15	
.0310	.0310	.0310	.047	.1250	1.5	SME-031-2	16.55	SME-031-2X	19.05	
.0310	.0310	.0310	.093	.1250	1.5	RME-031-2	16.65			
0.8 mm	.0315	.0315	2.4 mm	2	3 mm	38 mm	RMEM-008-2	16.00	RMEM-008-2X	18.50
0.8 mm	.0315	.0315	2.4 mm	2	4 mm	50 mm	AMRM-008-2	17.35		
.0320	.0320	.0320	.096	.1250	1.5	RME-032-2	16.65	RME-032-2X	19.15	
.0340	.0340	.0340	.051	.1250	1.5			SME-034-2X	19.05	
.0340	.0340	.0340	.102	.1250	1.5			RME-034-2X	19.15	
.0350	.0350	.0350	.053	.1250	1.5	SME-035-2	16.55			
.0350	.0350	.0350	.105	.1250	1.5	RME-035-2	16.65	RME-035-2X	19.15	
0.9 mm	.0354	.0354	2.7 mm	2	3 mm	38 mm	RMEM-009-2	16.00	RMEM-009-2X	18.50
0.9 mm	.0354	.0354	2.7 mm	2	4 mm	50 mm			AMRM-009-2X	20.25
1 mm	.0394	.0394	3 mm	2	3 mm	38 mm	RMEM-010-2	16.00	RMEM-010-2X	18.50
1 mm	.0394	.0394	3 mm	2	4 mm	50 mm	AMRM-010-2	17.35	AMRM-010-2X	20.25
.0400	.0400	.0400	.060	.1250	1.5	SME-040-2	16.55	SME-040-2X	19.05	
.0400	.0400	.0400	.120	.1250	1.5	RME-040-2	16.65	RME-040-2X	19.15	
1.1 mm	.0433	.0433	3.3 mm	2	3 mm	38 mm	RMEM-011-2	16.00	RMEM-011-2X	18.50
1.1 mm	.0433	.0433	3.3 mm	2	4 mm	50 mm	AMRM-011-2	17.35		
.0450	.0450	.0450	.068	.1250	1.5	SME-045-2	16.55	SME-045-2X	19.05	
.0450	.0450	.0450	.135	.1250	1.5	RME-045-2	16.65	RME-045-2X	19.15	

\*.0005" / .013 mm max TIR

Continued on next page

## End Mills – Square 2 Flute – Stub & Standard – Miniature (cont.)

RME / RMEM  
SME / AMRM

Continued from previous page

End Mills

Cutter Diameter*			Length of Cut	Flutes	Shank Diameter	Overall Length	Uncoated		AITIN Coated	
D1 +.0005" -.0005"	+.00 mm -.02 mm	decimal equiv.	L2 +.010" -.000" +.25 mm -.00 mm	D2 (h6)	L1	Tool #	Price	Tool #	Price	
1.2 mm		.0472	3.8 mm	2	3 mm	38 mm	RMEM-012-2	16.00	RMEM-012-2X	18.50
1.2 mm		.0472	3.8 mm	2	4 mm	50 mm	AMRM-012-2	17.35	AMRM-012-2X	20.25
.0500		.0500	.075	2	.1250	1.5	SME-050-2	16.55	SME-050-2X	19.05
.0500		.0500	.150	2	.1250	1.5	RME-050-2	16.65	RME-050-2X	19.15
1.3 mm		.0512	3.9 mm	2	3 mm	38 mm	RMEM-013-2	16.00	RMEM-013-2X	18.50
1.3 mm		.0512	3.9 mm	2	4 mm	50 mm	AMRM-013-2	17.35	AMRM-013-2X	20.25
1.4 mm		.0551	4.2 mm	2	3 mm	38 mm	RMEM-014-2	16.00	RMEM-014-2X	18.50
1.4 mm		.0551	4.2 mm	2	4 mm	50 mm			AMRM-014-2X	20.25
1.5 mm		.0591	4.2 mm	2	3 mm	38 mm	RMEM-015-2	16.00	RMEM-015-2X	18.50
1.5 mm		.0591	4.2 mm	2	4 mm	50 mm	AMRM-015-2	17.35	AMRM-015-2X	20.25
1.6 mm		.0630	4.8 mm	2	3 mm	38 mm	RMEM-016-2	14.80	RMEM-016-2X	17.30
1.6 mm		.0630	4.8 mm	2	4 mm	50 mm	AMRM-016-2	17.35	AMRM-016-2X	20.25
1.7 mm		.0669	5.1 mm	2	3 mm	38 mm	RMEM-017-2	14.80	RMEM-017-2X	17.30
1.7 mm		.0669	5.1 mm	2	4 mm	50 mm			AMRM-017-2X	20.25
1.8 mm		.0709	5.3 mm	2	3 mm	38 mm	RMEM-018-2	14.80	RMEM-018-2X	17.30
1.8 mm		.0709	5.3 mm	2	4 mm	50 mm	AMRM-018-2	17.35	AMRM-018-2X	20.25
1.9 mm		.0748	5.7 mm	2	3 mm	38 mm	RMEM-019-2	14.80	RMEM-019-2X	17.30
1.9 mm		.0748	5.7 mm	2	4 mm	50 mm	AMRM-019-2	17.35	AMRM-019-2X	20.25
2 mm		.0787	6 mm	2	3 mm	38 mm	RMEM-020-2	14.80	RMEM-020-2X	17.30
2 mm		.0787	6 mm	2	4 mm	50 mm	AMRM-020-2	17.35	AMRM-020-2X	20.25
2.5 mm		.0984	8 mm	2	3 mm	38 mm	RMEM-025-2	14.80	RMEM-025-2X	17.30
2.5 mm		.0984	8 mm	2	4 mm	50 mm	AMRM-025-2	17.35	AMRM-025-2X	20.25
3 mm		.1181	9 mm	2	4 mm	50 mm	AMRM-030-2	17.35	AMRM-030-2X	20.25
3.5 mm		.1378	10.5 mm	2	4 mm	50 mm			AMRM-035-2X	20.25

\*.0005" / .013 mm max TIR

**GEM / GEMM  
SEM / AEMM**

**End Mills – Square**  
2, 3, 4 Flute

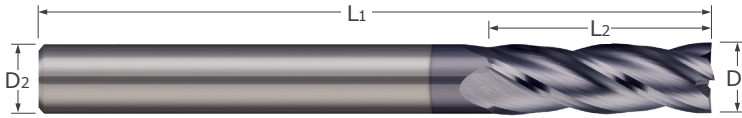

- Designed for general purpose machining
- 30° helix ■ Center cutting ■ Square profile
- AlTiN coating option for added lubricity and increased wear resistance in difficult-to-machine materials
- Solid carbide ■ CNC ground in the USA

Cutter Diameter*			Length of Cut	Flutes	Shank Diameter	Overall Length	Uncoated		AlTiN Coated	
D1 + .0000" - .0020"	(h9)	decimal equiv.	L2 + .030" - .000" + .78 mm - .00 mm		D2 (h6)	L1	Tool #	Price	Tool #	Price
.0312		.0312	.063	2	.1250	1.5	SEM-031-02	14.25	SEM-031-02X	16.75
.0312		.0312	.063	3	.1250	1.5	SEM-031-03	14.25	SEM-031-03X	16.75
.0312		.0312	.063	4	.1250	1.5	SEM-031-04	14.25	SEM-031-04X	16.75
.0312		.0312	.078	2	.1250	1.5	GEM-031-2	14.90	GEM-031-2X	17.40
.0312		.0312	.078	3	.1250	1.5	GEM-031-3	14.90	GEM-031-3X	17.40
.0312		.0312	.078	4	.1250	1.5	GEM-031-4	14.90	GEM-031-4X	17.40
1 mm		.0394	3 mm	2	3 mm	38 mm	GEMM-010-2	14.30	GEMM-010-2X	16.80
1 mm		.0394	3 mm	3	3 mm	38 mm	GEMM-010-3	14.30	GEMM-010-3X	16.80
1 mm		.0394	3 mm	4	3 mm	38 mm	GEMM-010-4	14.30		
1 mm		.0394	4 mm	2	4 mm	50 mm			AEMM-010-2X	20.25
1 mm		.0394	4 mm	3	4 mm	50 mm	AEMM-010-3	17.35	AEMM-010-3X	20.25
1 mm		.0394	4 mm	4	4 mm	50 mm	AEMM-010-4	17.35	AEMM-010-4X	20.25
.0469		.0469	.094	2	.1250	1.5	SEM-046-02	14.25	SEM-046-02X	16.75
.0469		.0469	.094	3	.1250	1.5	SEM-046-03	14.25	SEM-046-03X	16.75
.0469		.0469	.094	4	.1250	1.5	SEM-046-04	14.25	SEM-046-04X	16.75
.0469		.0469	.109	2	.1250	1.5	GEM-046-2	14.90	GEM-046-2X	17.40
.0469		.0469	.109	3	.1250	1.5	GEM-046-3	14.90	GEM-046-3X	17.40
.0469		.0469	.109	4	.1250	1.5	GEM-046-4	14.90	GEM-046-4X	17.40
1.5 mm		.0591	4 mm	2	4 mm	50 mm	AEMM-015-2	17.35	AEMM-015-2X	20.25
1.5 mm		.0591	4 mm	3	4 mm	50 mm	AEMM-015-3	17.35	AEMM-015-3X	20.25
1.5 mm		.0591	4 mm	4	4 mm	50 mm	AEMM-015-4	17.35	AEMM-015-4X	20.25
.0625		.0625	.125	2	.1250	1.5	SEM-062-02	12.90	SEM-062-02X	15.40
.0625		.0625	.125	3	.1250	1.5	SEM-062-03	12.90	SEM-062-03X	15.40
.0625		.0625	.125	4	.1250	1.5	SEM-062-04	12.90	SEM-062-04X	15.40
.0625		.0625	.188	2	.1250	1.5	GEM-062-2	13.65	GEM-062-2X	16.15
.0625		.0625	.188	3	.1250	1.5	GEM-062-3	13.65	GEM-062-3X	16.15
.0625		.0625	.188	4	.1250	1.5	GEM-062-4	13.65	GEM-062-4X	16.15
.0781		.0781	.156	2	.1250	1.5	SEM-078-02	12.90	SEM-078-02X	15.40
.0781		.0781	.156	3	.1250	1.5	SEM-078-03	12.90	SEM-078-03X	15.40
.0781		.0781	.156	4	.1250	1.5	SEM-078-04	12.90	SEM-078-04X	15.40
.0781		.0781	.188	2	.1250	1.5	GEM-078-2	13.65	GEM-078-2X	16.15
.0781		.0781	.188	3	.1250	1.5	GEM-078-3	13.65	GEM-078-3X	16.15
.0781		.0781	.188	4	.1250	1.5	GEM-078-4	13.65	GEM-078-4X	16.15
2 mm		.0787	5 mm	2	4 mm	50 mm	AEMM-020-2	17.35	AEMM-020-2X	20.25
2 mm		.0787	5 mm	3	4 mm	50 mm	AEMM-020-3	17.35	AEMM-020-3X	20.25
2 mm		.0787	5 mm	4	4 mm	50 mm	AEMM-020-4	17.35	AEMM-020-4X	20.25
2 mm		.0787	6 mm	2	3 mm	38 mm	GEMM-020-2	12.95	GEMM-020-2X	15.45
2 mm		.0787	6 mm	3	3 mm	38 mm			GEMM-020-3X	15.45
2 mm		.0787	7 mm	4	3 mm	38 mm	GEMM-020-4	12.95	GEMM-020-4X	15.45

\*.0005" / .013 mm max TIR

Continued on next page

# End Mills – Square

## 2, 3, 4 Flute (cont.)

GEM / GEMM  
SEM / AEMM

Continued from previous page

End Mills

Cutter Diameter*		Length of Cut	Flutes	Shank Diameter	Overall Length	Uncoated		AITIN Coated	
D <sub>1</sub> +.0000" -.0020"	decimal equiv. (h9)					L <sub>2</sub> +.030" -.000" +.78 mm -.00 mm	D <sub>2</sub> (h6)	L <sub>1</sub>	Tool #
.0938	.0938	.188	2	.1250	1.5	SEM-093-02	12.90	SEM-093-02X	15.40
.0938	.0938	.188	3	.1250	1.5	SEM-093-03	12.90	SEM-093-03X	15.40
.0938	.0938	.188	4	.1250	1.5	SEM-093-04	12.90	SEM-093-04X	15.40
.0938	.0938	.375	2	.1250	1.5	GEM-093-2	13.65	GEM-093-2X	16.15
.0938	.0938	.375	3	.1250	1.5	GEM-093-3	13.65	GEM-093-3X	16.15
.0938	.0938	.375	4	.1250	1.5	GEM-093-4	13.65	GEM-093-4X	16.15
2.5 mm	.0984	6 mm	2	4 mm	50 mm	AEMM-025-2	17.35	AEMM-025-2X	20.25
2.5 mm	.0984	6 mm	3	4 mm	50 mm	AEMM-025-3	17.35	AEMM-025-3X	20.25
2.5 mm	.0984	6 mm	4	4 mm	50 mm	AEMM-025-4	17.35	AEMM-025-4X	20.25
.1094	.1094	.188	2	.1250	1.5	SEM-109-02	12.90	SEM-109-02X	15.40
.1094	.1094	.188	3	.1250	1.5	SEM-109-03	12.90	SEM-109-03X	15.40
.1094	.1094	.188	4	.1250	1.5	SEM-109-04	12.90	SEM-109-04X	15.40
.1094	.1094	.375	2	.1250	1.5	GEM-109-2	13.65	GEM-109-2X	16.15
.1094	.1094	.375	3	.1250	1.5	GEM-109-3	13.65	GEM-109-3X	16.15
.1094	.1094	.375	4	.1250	1.5	GEM-109-4	13.65	GEM-109-4X	16.15
3 mm	.1181	7 mm	2	3 mm	38 mm	GEMM-030-2	11.60	GEMM-030-2X	14.10
3 mm	.1181	7 mm	3	3 mm	38 mm	GEMM-030-3	11.60	GEMM-030-3X	14.10
3 mm	.1181	8 mm	4	3 mm	38 mm	GEMM-030-4	11.60	GEMM-030-4X	14.10
3 mm	.1181	8 mm	2	6 mm	57 mm	AEMM-030-2	21.75	AEMM-030-2X	26.65
3 mm	.1181	8 mm	3	6 mm	57 mm	AEMM-030-3	21.75		
3 mm	.1181	8 mm	4	6 mm	57 mm	AEMM-030-4	21.75	AEMM-030-4X	26.65
.1250	.1250	.250	2	.1250	1.5	SEM-125-02	11.50	SEM-125-02X	14.00
.1250	.1250	.250	3	.1250	1.5	SEM-125-03	11.50	SEM-125-03X	14.00
.1250	.1250	.250	4	.1250	1.5	SEM-125-04	11.50	SEM-125-04X	14.00
.1250	.1250	.500	2	.1250	1.5	GEM-125-2	12.15	GEM-125-2X	14.65
.1250	.1250	.500	3	.1250	1.5	GEM-125-3	12.15	GEM-125-3X	14.65
.1250	.1250	.500	4	.1250	1.5	GEM-125-4	12.15	GEM-125-4X	14.65
3.5 mm	.1378	10 mm	2	6 mm	57 mm			AEMM-035-2X	26.65
3.5 mm	.1378	10 mm	3	6 mm	57 mm	AEMM-035-3	21.75	AEMM-035-3X	26.65
3.5 mm	.1378	10 mm	4	6 mm	57 mm	AEMM-035-4	21.75	AEMM-035-4X	26.65
.1406	.1406	.250	2	.1875	1.5	SEM-140-02	18.35	SEM-140-02X	21.25
.1406	.1406	.250	3	.1875	1.5	SEM-140-03	18.35	SEM-140-03X	21.25
.1406	.1406	.250	4	.1875	1.5	SEM-140-04	18.35	SEM-140-04X	21.25
.1406	.1406	.500	2	.1875	2.0	GEM-140-2	19.25	GEM-140-2X	22.15
.1406	.1406	.500	3	.1875	2.0	GEM-140-3	19.25	GEM-140-3X	22.15
.1406	.1406	.500	4	.1875	2.0	GEM-140-4	19.25	GEM-140-4X	22.15
.1562	.1562	.313	2	.1875	1.5	SEM-156-02	18.35	SEM-156-02X	21.25
.1562	.1562	.313	3	.1875	1.5	SEM-156-03	18.35	SEM-156-03X	21.25
.1562	.1562	.313	4	.1875	1.5	SEM-156-04	18.35	SEM-156-04X	21.25
.1562	.1562	.563	2	.1875	2.0	GEM-156-2	19.25	GEM-156-2X	22.15
.1562	.1562	.563	3	.1875	2.0	GEM-156-3	19.25	GEM-156-3X	22.15
.1562	.1562	.563	4	.1875	2.0	GEM-156-4	19.25	GEM-156-4X	22.15
4 mm	.1575	8 mm	2	4 mm	50 mm	GEMM-040-2	17.35		
4 mm	.1575	8 mm	3	4 mm	50 mm	GEMM-040-3	17.35		
4 mm	.1575	11 mm	4	4 mm	50 mm	GEMM-040-4	17.35	GEMM-040-4X	20.25
4 mm	.1575	11 mm	2	6 mm	57 mm	AEMM-040-2	21.75	AEMM-040-2X	26.65
4 mm	.1575	11 mm	3	6 mm	57 mm	AEMM-040-3	21.75	AEMM-040-3X	26.65
4 mm	.1575	11 mm	4	6 mm	57 mm	AEMM-040-4	21.75	AEMM-040-4X	26.65

\*.0005" / .013 mm max TIR

Continued on next page



**GEM / GEMM  
SEM / AEMM**

**End Mills – Square  
2, 3, 4 Flute (cont.)**

Continued from previous page

Cutter Diameter*			Length of Cut	Flutes	Shank Diameter	Overall Length	Uncoated		AITIN Coated	
D <sub>1</sub> +.0000" -.0020" (h9)	decimal equiv.	L <sub>2</sub> +.030" -.000" +.78 mm -.00 mm	D <sub>2</sub> (h6)	L <sub>1</sub>	Tool #	Price	Tool #	Price		
.1719	.1719	.313	3	.1875	1.5	SEM-171-03	18.35	SEM-171-03X	21.25	
.1719	.1719	.313	4	.1875	1.5	SEM-171-04	18.35	SEM-171-04X	21.25	
.1719	.1719	.625	2	.1875	2.0	GEM-171-2	19.25	GEM-171-2X	22.15	
.1719	.1719	.625	4	.1875	2.0	GEM-171-4	19.25	GEM-171-4X	22.15	
4.5 mm	.1772	11 mm	3	6 mm	57 mm	AEMM-045-3	21.75	AEMM-045-3X	26.65	
4.5 mm	.1772	11 mm	4	6 mm	57 mm	AEMM-045-4	21.75	AEMM-045-4X	26.65	
.1875	.1875	.375	2	.1875	1.5	SEM-187-02	18.35	SEM-187-02X	21.25	
.1875	.1875	.375	3	.1875	1.5	SEM-187-03	18.35	SEM-187-03X	21.25	
.1875	.1875	.375	4	.1875	1.5	SEM-187-04	18.35	SEM-187-04X	21.25	
.1875	.1875	.625	2	.1875	2.0	GEM-187-2	19.25	GEM-187-2X	22.15	
.1875	.1875	.625	3	.1875	2.0	GEM-187-3	19.25	GEM-187-3X	22.15	
.1875	.1875	.625	4	.1875	2.0	GEM-187-4	19.25	GEM-187-4X	22.15	
5 mm	.1969	10 mm	2	6 mm	57 mm	GEMM-050-2	18.50	GEMM-050-2X	21.45	
5 mm	.1969	13 mm	4	6 mm	57 mm	GEMM-050-4	18.50	GEMM-050-4X	21.45	
5 mm	.1969	16 mm	2	6 mm	57 mm	AEMM-050-2	21.75	AEMM-050-2X	26.65	
5 mm	.1969	16 mm	3	6 mm	57 mm	AEMM-050-3X	26.65	AEMM-050-3X	26.65	
5 mm	.1969	16 mm	4	6 mm	57 mm	AEMM-050-4	21.75	AEMM-050-4X	26.65	
.2031	.2031	.375	3	.2500	2.0	SEM-203-03	22.80	SEM-203-03X	25.75	
.2031	.2031	.375	4	.2500	2.0	SEM-203-04	22.80	SEM-203-04X	25.75	
.2031	.2031	.625	2	.2500	2.5	GEM-203-2	24.05			
.2031	.2031	.625	4	.2500	2.5	GEM-203-4	24.05	GEM-203-4X	28.95	
5.5 mm	.2165	16 mm	2	6 mm	57 mm	AEMM-055-2	21.75			
5.5 mm	.2165	16 mm	3	6 mm	57 mm	AEMM-055-3	21.75			
5.5 mm	.2165	16 mm	4	6 mm	57 mm	AEMM-055-4	21.75	AEMM-055-4X	26.65	
.2187	.2187	.438	4	.2500	2.0	SEM-218-04	22.80	SEM-218-04X	25.75	
.2187	.2187	.625	2	.2500	2.5	GEM-218-2	24.05	GEM-218-2X	28.95	
.2187	.2187	.625	4	.2500	2.5	GEM-218-4	24.05			
.2344	.2344	.438	4	.2500	2.0	SEM-234-04	22.80	SEM-234-04X	25.75	
6 mm	.2362	10 mm	2	6 mm	57 mm	GEMM-060-2	21.75	GEMM-060-2X	26.65	
6 mm	.2362	10 mm	3	6 mm	57 mm	GEMM-060-3	21.75			
6 mm	.2362	13 mm	4	6 mm	57 mm	GEMM-060-4	21.75	GEMM-060-4X	26.65	
6 mm	.2362	16 mm	2	6 mm	57 mm	AEMM-060-2	21.75	AEMM-060-2X	26.65	
6 mm	.2362	16 mm	3	6 mm	57 mm	AEMM-060-3	21.75	AEMM-060-3X	26.65	
6 mm	.2362	16 mm	4	6 mm	57 mm	AEMM-060-4	21.75	AEMM-060-4X	26.65	
.2500	.2500	.500	2	.2500	2.0	SEM-250-02	22.80	SEM-250-02X	25.75	
.2500	.2500	.500	3	.2500	2.0	SEM-250-03	22.80	SEM-250-03X	25.75	
.2500	.2500	.500	4	.2500	2.0	SEM-250-04	22.80	SEM-250-04X	25.75	
.2500	.2500	.750	2	.2500	2.5	GEM-250-2	24.05	GEM-250-2X	28.95	
.2500	.2500	.750	3	.2500	2.5	GEM-250-3	24.05	GEM-250-3X	28.95	
.2500	.2500	.750	4	.2500	2.5	GEM-250-4	24.05	GEM-250-4X	28.95	
.2656	.2656	.500	4	.3125	2.0	SEM-265-04	25.25	SEM-265-04X	32.05	
7 mm	.2756	22 mm	3	8 mm	63 mm			AEMM-070-3X	33.70	
7 mm	.2756	22 mm	4	8 mm	63 mm	AEMM-070-4	26.90	AEMM-070-4X	33.70	

\*.0005" / .013 mm max TIR

Continued on next page

# End Mills – Square

## 2, 3, 4 Flute (cont.)

**GEM / GEMM**  
**SEM / AEMM**

Continued from previous page

End Mills

Cutter Diameter*		Length of Cut	Flutes	Shank Diameter	Overall Length	Uncoated		AITIN Coated	
D <sub>1</sub>		L <sub>2</sub>		D <sub>2</sub> (h6)	L <sub>1</sub>	Tool #	Price	Tool #	Price
+ .0000" - .0030"	decimal equiv. (h9)	+ .030" - .000" + .78 mm - .00 mm							
.2812	.2812	.500	4	.3125	2.0	SEM-281-04	25.25	SEM-281-04X	32.05
.2812	.2812	.750	2	.3125	2.5	GEM-281-2	28.00	GEM-281-2X	34.80
.2812	.2812	.750	3	.3125	2.5	GEM-281-3	28.00	GEM-281-3X	34.80
.2812	.2812	.750	4	.3125	2.5	GEM-281-4	28.00	GEM-281-4X	34.80
.3125	.3125	.500	2	.3125	2.0	SEM-312-02	25.25	SEM-312-02X	32.05
.3125	.3125	.500	4	.3125	2.0	SEM-312-04	25.25	SEM-312-04X	32.05
.3125	.3125	.813	2	.3125	2.5	GEM-312-2	28.00	GEM-312-2X	34.80
.3125	.3125	.813	4	.3125	2.5	GEM-312-4	28.00	GEM-312-4X	34.80
8 mm	.3150	16 mm	2	8 mm	63 mm	GEMM-080-2	26.90	GEMM-080-2X	33.70
8 mm	.3150	19 mm	4	8 mm	63 mm	GEMM-080-4	26.90		
8 mm	.3150	22 mm	2	8 mm	63 mm	AEMM-080-2	26.90	AEMM-080-2X	33.70
8 mm	.3150	22 mm	3	8 mm	63 mm	AEMM-080-3	26.90	AEMM-080-3X	33.70
8 mm	.3150	22 mm	4	8 mm	63 mm	AEMM-080-4	26.90	AEMM-080-4X	33.70
.3281	.3281	.500	2	.3750	2.0	SEM-328-02	30.15	SEM-328-02X	35.95
.3281	.3281	.500	3	.3750	2.0	SEM-328-03	30.15	SEM-328-03X	35.95
.3281	.3281	.500	4	.3750	2.0	SEM-328-04	30.15		
.3750	.3750	.625	2	.3750	2.0	SEM-375-02	30.15	SEM-375-02X	35.35
.3750	.3750	.625	3	.3750	2.0	SEM-375-03	30.15	SEM-375-03X	35.35
.3750	.3750	.625	4	.3750	2.0	SEM-375-04	30.15	SEM-375-04X	35.35
.3750	.3750	.875	2	.3750	2.5	GEM-375-2	31.75	GEM-375-2X	38.55
.3750	.3750	.875	3	.3750	2.5	GEM-375-3	31.75	GEM-375-3X	38.55
.3750	.3750	.875	4	.3750	2.5	GEM-375-4	31.75	GEM-375-4X	38.55
.3906	.3906	.625	4	.4375	2.5	SEM-390-04	45.10	SEM-390-04X	53.30
10 mm	.3937	19 mm	2	10 mm	72 mm	GEMM-100-2	31.70	GEMM-100-2X	38.50
10 mm	.3937	19 mm	3	10 mm	72 mm	GEMM-100-3	31.70	GEMM-100-3X	38.50
10 mm	.3937	22 mm	4	10 mm	72 mm	GEMM-100-4	31.70	GEMM-100-4X	38.50
10 mm	.3937	22 mm	2	10 mm	72 mm	AEMM-100-2	31.70	AEMM-100-2X	38.50
10 mm	.3937	22 mm	3	10 mm	72 mm	AEMM-100-3	31.70	AEMM-100-3X	38.50
10 mm	.3937	22 mm	4	10 mm	72 mm	AEMM-100-4	31.70	AEMM-100-4X	38.50
.4063	.4063	.625	2	.4375	2.5			SEM-406-02X	53.30
11 mm	.4331	30 mm	2	12 mm	83 mm			AEMM-110-2X	60.80
11 mm	.4331	30 mm	3	12 mm	83 mm	AEMM-110-3	50.50		
.4375	.4375	1.000	4	.4375	2.5	GEM-437-4	50.10	GEM-437-4X	58.30
.4531	.4531	.625	2	.5000	2.5			SEM-453-02X	57.75
12 mm	.4724	22 mm	2	12 mm	83 mm	GEMM-120-2	50.50	GEMM-120-2X	60.80
12 mm	.4724	22 mm	3	12 mm	83 mm	GEMM-120-3	50.50	GEMM-120-3X	60.80
12 mm	.4724	30 mm	2	12 mm	83 mm	AEMM-120-2	50.50	AEMM-120-2X	60.80
12 mm	.4724	30 mm	3	12 mm	83 mm	AEMM-120-3	50.50		
12 mm	.4724	30 mm	4	12 mm	83 mm	AEMM-120-4	50.50	AEMM-120-4X	60.80
.5000	.5000	.625	2	.5000	2.5	SEM-500-02	49.65	SEM-500-02X	57.75
.5000	.5000	.625	3	.5000	2.5	SEM-500-03	49.65	SEM-500-03X	57.75
.5000	.5000	.625	4	.5000	2.5	SEM-500-04	49.65	SEM-500-04X	57.75
.5000	.5000	1.000	2	.5000	3.0	GEM-500-2	55.15	GEM-500-2X	63.35
.5000	.5000	1.000	3	.5000	3.0	GEM-500-3	55.15	GEM-500-3X	63.35
.5000	.5000	1.000	4	.5000	3.0	GEM-500-4	55.15	GEM-500-4X	63.35
.5000	.5000	1.250	4	.5000	3.5	GEM-5125-4	57.95	GEM-5125-4X	65.10

\*.0005" / .013 mm max TIR

Continued on next page

**GEM / GEMM  
SEM / AEMM**
**End Mills – Square  
2, 3, 4 Flute (cont.)**

Continued from previous page

Cutter Diameter*			Length of Cut	Flutes	Shank Diameter	Overall Length	Uncoated		AITIN Coated	
D <sub>1</sub>		decimal equiv.					L <sub>2</sub>	D <sub>2</sub> (h6)	L <sub>1</sub>	Tool #
+ .0000" - .0030"	(h9)		+ .030" - .000" + .78 mm - .00 mm							
14 mm		.5512	22 mm	3	14 mm	83 mm			GEMM-140-3X	70.05
14 mm		.5512	26 mm	4	14 mm	83 mm	GEMM-140-4	58.65	GEMM-140-4X	70.05
14 mm		.5512	35 mm	2	14 mm	83 mm	AEMM-140-2	58.65	AEMM-140-2X	70.05
14 mm		.5512	35 mm	3	14 mm	83 mm	AEMM-140-3	58.65		
14 mm		.5512	35 mm	4	14 mm	83 mm	AEMM-140-4	58.65	AEMM-140-4X	70.05
.5625		.5625	1.250	2	.5625	3.5	GEM-562-2	84.65		
.5625		.5625	1.250	4	.5625	3.5	GEM-562-4	84.65	GEM-562-4X	97.05
.6250		.6250	1.250	4	.6250	3.5	GEM-625-4	97.35	GEM-625-4X	109.75
16 mm		.6299	26 mm	2	16 mm	92 mm	GEMM-160-2	93.55	GEMM-160-2X	105.95
16 mm		.6299	26 mm	3	16 mm	92 mm	GEMM-160-3	93.55	GEMM-160-3X	105.95
16 mm		.6299	32 mm	4	16 mm	92 mm	GEMM-160-4	93.55		
16 mm		.6299	35 mm	3	16 mm	92 mm			AEMM-160-3X	105.95
16 mm		.6299	35 mm	4	16 mm	92 mm	AEMM-160-4	93.55	AEMM-160-4X	105.95
18 mm		.7087	26 mm	2	18 mm	92 mm	GEMM-180-2	125.75		
18 mm		.7087	26 mm	3	18 mm	92 mm	GEMM-180-3	125.75	GEMM-180-3X	140.05
18 mm		.7087	32 mm	4	18 mm	92 mm	GEMM-180-4	125.75		
18 mm		.7087	45 mm	3	18 mm	92 mm	AEMM-180-3	125.75	AEMM-180-3X	140.05
.7500		.7500	1.500	2	.7500	4.0	GEM-750-2	148.35	GEM-750-2X	162.65
.7500		.7500	1.500	4	.7500	4.0	GEM-750-4	148.35	GEM-750-4X	162.65
20 mm		.7874	32 mm	3	20 mm	104 mm	GEMM-200-3	159.75	GEMM-200-3X	179.75
20 mm		.7874	38 mm	4	20 mm	104 mm	GEMM-200-4	159.75		
20 mm		.7874	45 mm	2	20 mm	104 mm			AEMM-200-2X	179.75
20 mm		.7874	45 mm	3	20 mm	104 mm	AEMM-200-3	159.75	AEMM-200-3X	179.75
20 mm		.7874	45 mm	4	20 mm	104 mm	AEMM-200-4	159.75	AEMM-200-4X	179.75
.8750		.8750	1.500	4	.8750	4.0	GEM-875-4	205.60		
25 mm		.9843	50 mm	2	25 mm	127 mm			AEMM-250-2X	212.85
25 mm		.9843	50 mm	3	25 mm	127 mm	AEMM-250-3	190.05	AEMM-250-3X	212.85
25 mm		.9843	50 mm	4	25 mm	127 mm	AEMM-250-4	190.05	AEMM-250-4X	212.85
1.0000		1.0000	1.500	4	1.0000	4.0	GEM-001-4	224.75		

\*.0005" / .013 mm max TIR

# End Mills – Square

## 2, 3, 4 Flute – Long Flute

GEL / GELM / AELM

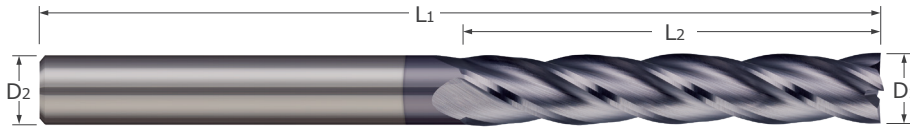

End Mills

- Long flutes for deep pocket milling and long length peripheral milling
- AlTiN coating option for added lubricity and increased wear resistance in difficult-to-machine materials
- 30° helix ■ Center cutting
- Square profile
- Solid carbide ■ CNC ground in the USA

Cutter Diameter*			Length of Cut	Flutes	Shank Diameter	Overall Length	Uncoated		AlTiN Coated	
D1 +.0000" -.0020"	(h9)	decimal equiv.	L2 +.031" -.000" +.79 mm -.00 mm	D2 (h6)	L1	Tool #	Price	Tool #	Price	
										2 mm
2 mm	.0787	10 mm	4	6 mm	75 mm			AELM-020-4X	32.10	
3 mm	.1181	15 mm	2	6 mm	75 mm	AELM-030-2	27.20			
3 mm	.1181	15 mm	4	6 mm	75 mm	AELM-030-4	27.20	AELM-030-4X	32.10	
3 mm	.1181	25 mm	3	3 mm	75 mm			GELM-030-3X	21.55	
3 mm	.1181	25 mm	4	3 mm	75 mm	GELM-030-4	18.65	GELM-030-4X	21.55	
4 mm	.1575	20 mm	2	6 mm	75 mm			AELM-040-2X	32.10	
4 mm	.1575	20 mm	4	6 mm	75 mm	AELM-040-4	27.20	AELM-040-4X	32.10	
4 mm	.1575	25 mm	2	4 mm	75 mm			GELM-040-2X	24.05	
4 mm	.1575	25 mm	3	4 mm	75 mm	GELM-040-3	20.15			
4 mm	.1575	25 mm	4	4 mm	75 mm	GELM-040-4	20.15			
.1875	.1875	1.125	4	.1875	3.0	GEL-187-4	28.15			
5 mm	.1969	25 mm	3	5 mm	75 mm	GELM-050-3	23.65			
5 mm	.1969	25 mm	4	5 mm	75 mm	GELM-050-4	23.65	GELM-050-4X	28.55	
5 mm	.1969	25 mm	4	6 mm	100 mm	AELM-050-4	34.95	AELM-050-4X	39.85	
6 mm	.2362	25 mm	2	6 mm	75 mm			GELM-060-2X	35.2	
6 mm	.2362	25 mm	3	6 mm	75 mm	GELM-060-3	30.30	GELM-060-3X	35.2	
6 mm	.2362	25 mm	4	6 mm	75 mm	GELM-060-4	30.30	GELM-060-4X	35.2	
6 mm	.2362	30 mm	4	6 mm	100 mm	AELM-060-4	34.95	AELM-060-4X	39.85	
.2500	.2500	1.500	2	.2500	4.0	GEL-250-2	33.85			
.2500	.2500	1.500	4	.2500	4.0	GEL-250-4	33.85			

D1 +.0000" -.0030"	(h9)	decimal equiv.	L2 +.031" -.000" +.79 mm -.00 mm	D2 (h6)	L1	Tool #	Price	Tool #	Price
8 mm	.3150	30 mm	3	8 mm	75 mm	GELM-080-3	36.45	GELM-080-3X	43.25
8 mm	.3150	40 mm	2	8 mm	100 mm	AELM-080-2	47.75	AELM-080-2X	53.55
8 mm	.3150	40 mm	4	8 mm	100 mm	AELM-080-4	47.75		
.3750	.3750	1.750	2	.3750	4.0	GEL-375-2	44.90		
.3750	.3750	1.750	4	.3750	4.0	GEL-375-4	44.90		
10 mm	.3937	38 mm	2	10 mm	100 mm	GELM-100-2	46.10	GELM-100-2X	54.50
10 mm	.3937	38 mm	3	10 mm	100 mm	GELM-100-3	46.10	GELM-100-3X	54.50
10 mm	.3937	50 mm	2	10 mm	120 mm	AELM-100-2	56.30	AELM-100-2X	66.10
10 mm	.3937	50 mm	4	10 mm	120 mm	AELM-100-4	56.30	AELM-100-4X	66.10

\*.0005" / .013 mm max TIR

Continued on next page

## GEL / GELM / AELM

## End Mills – Square

### 2, 3, 4 Flute – Long Flute (cont.)

Continued from previous page

Cutter Diameter*			Length of Cut	Flutes	Shank Diameter	Overall Length	Uncoated		AlTiN Coated	
D1 +.0000" -.0030"	(h9)	decimal equiv.	L2 +.031" -.000" +.79 mm -.00 mm	D2 (h6)	L1	Tool #	Price	Tool #	Price	
										11 mm
12 mm	.4724	50 mm	3	12 mm	100 mm			GELM-120-3X	77.60	
12 mm	.4724	55 mm	4	12 mm	130 mm	AELM-120-4	78.85			
.5000	.5000	3.000	2	.5000	6.0	GEL-500-2	80.85	GEL-500-2X	94.85	
.5000	.5000	3.000	4	.5000	6.0	GEL-500-4	80.85			
14 mm	.5512	60 mm	2	14 mm	140 mm			AELM-140-2X	135.25	
14 mm	.5512	75 mm	2	14 mm	150 mm	GELM-140-2	100.30			
14 mm	.5512	75 mm	3	14 mm	150 mm			GELM-140-3X	116.70	
16 mm	.6299	65 mm	4	16 mm	150 mm			AELM-160-4X	144.50	
18 mm	.7087	75 mm	2	18 mm	150 mm	GELM-180-2	169.20	GELM-180-2X	189.00	
18 mm	.7087	75 mm	3	18 mm	150 mm	GELM-180-3	169.20	GELM-180-3X	189.00	
20 mm	.7874	75 mm	2	20 mm	150 mm			AELM-200-2X	252.95	
25 mm	.9843	75 mm	2	25 mm	150 mm			GELM-250-2X	306.20	
25 mm	.9843	75 mm	3	25 mm	150 mm	GELM-250-3	281.10			
25 mm	.9843	75 mm	4	25 mm	150 mm			GELM-250-4X	306.20	

\*.0005" / .013 mm max TIR

# End Mills – Square

## 2 & 4 Flute – Reduced Neck

GLR / GLRM

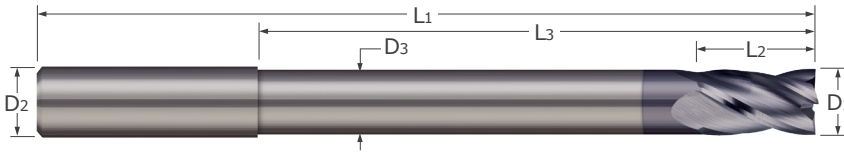

End Mills

- Long reach design for deep cavities
- Reduced neck diameter to avoid heeling
- AlTiN coating option for added lubricity and increased wear resistance in difficult-to-machine materials
- 30° helix ■ Center cutting ■ Square profile
- Solid carbide ■ CNC ground in the USA

Cutter Diameter*			Length of Cut	Overall Reach	Neck Dia.	Flutes	Shank Dia.	Overall Length	Uncoated		AlTiN Coated	
D1			L2	L3	D3		D2 (h6)	L1	Tool #	Price	Tool #	Price
+ .0000" - .0020"	(h9)	decimal equiv.	+ .015" - .000" + .38 mm - .00 mm	+ .015" - .015" + .38 mm - .38 mm								
2 mm		.0787	5 mm	15 mm	1.5 mm	4	6 mm	57 mm	GLRM-020-4	25.60		
3 mm		.1181	8 mm	30 mm	2.5 mm	2	6 mm	75 mm	GLRM-030-2	33.15	GLRM-030-2X	38.05
3 mm		.1181	8 mm	30 mm	2.5 mm	4	6 mm	75 mm	GLRM-030-4	33.15	GLRM-030-4X	38.05
4 mm		.1575	8 mm	30 mm	3.5 mm	2	6 mm	75 mm	GLRM-040-2	33.15	GLRM-040-2X	38.05
4 mm		.1575	8 mm	30 mm	3.5 mm	4	6 mm	75 mm			GLRM-040-4X	38.05
.1875		.1875	.375	2.00	.1675	2	.1875	3.0	GLR-187-2	32.25		
.1875		.1875	.375	2.00	.1675	4	.1875	3.0	GLR-187-4	32.25	GLR-187-4X	36.25
5 mm		.1969	10 mm	50 mm	4.5 mm	4	6 mm	100 mm	GLRM-050-4	34.75	GLRM-050-4X	39.65
6 mm		.2362	12 mm	50 mm	5.5 mm	2	6 mm	100 mm	GLRM-060-2	34.75	GLRM-060-2X	39.65
6 mm		.2362	12 mm	50 mm	5.5 mm	4	6 mm	100 mm	GLRM-060-4	34.75	GLRM-060-4X	39.65
.2500		.2500	.500	2.50	.2300	2	.2500	4.0	GLR-250-2	38.95		
.2500		.2500	.500	2.50	.2300	4	.2500	4.0	GLR-250-4	38.95		

D1			L2	L3	D3		D2 (h6)	L1	Tool #	Price	Tool #	Price
+ .0000" - .0030"	(h9)	decimal equiv.	+ .015" - .000" + .38 mm - .00 mm	+ .015" - .015" + .38 mm - .38 mm								
.3125		.3125	.625	2.63	.2925	4	.3125	4.0	GLR-312-4	44.70		
8 mm		.3150	14 mm	50 mm	7.5 mm	2	8 mm	100 mm			GLRM-080-2X	55.75
.3750		.3750	.750	2.75	.3550	2	.3750	4.0	GLR-375-2	51.60		
.3750		.3750	.750	2.75	.3550	4	.3750	4.0			GLR-375-4X	60.00
10 mm		.3937	18 mm	65 mm	9.5 mm	2	10 mm	120 mm	GLRM-100-2	53.20	GLRM-100-2X	63.00
10 mm		.3937	18 mm	65 mm	9.5 mm	4	10 mm	120 mm	GLRM-100-4	53.20		
.4375		.4375	1.000	4.50	.4175	4	.4375	6.0	GLR-437-4	77.80		
12 mm		.4724	22 mm	80 mm	11.5 mm	2	12 mm	130 mm			GLRM-120-2X	86.60
12 mm		.4724	22 mm	80 mm	11.5 mm	4	12 mm	130 mm	GLRM-120-4	74.60	GLRM-120-4X	86.60
.5000		.5000	1.000	4.50	.4800	4	.5000	6.0	GLR-500-4	89.00	GLR-500-4X	103.00
.6250		.6250	1.250	4.50	.6050	2	.6250	6.0	GLR-625-2	157.75		
16 mm		.6299	30 mm	100 mm	15 mm	2	16 mm	150 mm			GLRM-160-2X	164.75

\*.0005" / .013 mm max TIR

EMS / EMSM

End Mills – Square  
2, 3, 4, 6 Flute – NC Tolerance

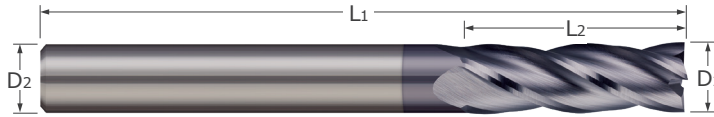

- General purpose end mill with .001" plus tolerance on the cutting diameter
- Weldon flat featured on sizes 3/8" and larger
- 30° helix ■ Center cutting ■ Square profile
- AlTiN coating option for added lubricity and increased wear resistance in difficult-to-machine materials
- Solid carbide ■ CNC ground in the USA

Cutter Diameter*			Length of Cut	Flutes	Shank Diameter	Overall Length	Uncoated		AlTiN Coated	
D1 +.0010" -.0000"	+.03 mm -.00 mm	decimal equiv.	L2 +.030" -.000" +.78 mm -.00 mm	D2 (h6)	L1	Tool #	Price	Tool #	Price	
										.0312
.0312	.0312	.0312	.078	3	.1250	1.5	EMS-031-3	17.95	EMS-031-3X	20.45
.0312	.0312	.0312	.078	4	.1250	1.5	EMS-031-4	17.95	EMS-031-4X	20.45
.0625	.0625	.0625	.188	2	.1250	1.5	EMS-062-2	16.30	EMS-062-2X	18.80
.0625	.0625	.0625	.188	3	.1250	1.5	EMS-062-3	16.30	EMS-062-3X	18.80
.0625	.0625	.0625	.188	4	.1250	1.5	EMS-062-4	16.30	EMS-062-4X	18.80
2 mm	.0787		10 mm	2	2 mm	38 mm			EMSM-020-2X	15.25
2 mm	.0787		10 mm	3	2 mm	38 mm			EMSM-020-3X	15.25
.0938	.0938	.0938	.375	2	.1250	1.5	EMS-093-2	16.30	EMS-093-2X	18.80
.0938	.0938	.0938	.375	3	.1250	1.5	EMS-093-3	16.30	EMS-093-3X	18.80
.0938	.0938	.0938	.375	4	.1250	1.5	EMS-093-4	16.30	EMS-093-4X	18.80
3 mm	.1181		15 mm	2	3 mm	38 mm	EMSM-030-2	12.75		
3 mm	.1181		15 mm	4	3 mm	38 mm	EMSM-030-4	12.75		
.1250	.1250	.1250	.500	2	.1250	1.5	EMS-125-2	14.55	EMS-125-2X	17.05
.1250	.1250	.1250	.500	3	.1250	1.5	EMS-125-3	14.55	EMS-125-3X	17.05
.1250	.1250	.1250	.500	4	.1250	1.5	EMS-125-4	14.55	EMS-125-4X	17.05
.1562	.1562	.1562	.563	2	.1875	2.0	EMS-156-2	23.00		
.1562	.1562	.1562	.563	3	.1875	2.0	EMS-156-3	23.00		
.1562	.1562	.1562	.563	4	.1875	2.0	EMS-156-4	23.00	EMS-156-4X	25.90
4 mm	.1575		18 mm	2	4 mm	50 mm	EMSM-040-2	19.05	EMSM-040-2X	21.95
.1875	.1875	.1875	.625	2	.1875	2.0	EMS-187-2	23.00		
.1875	.1875	.1875	.625	4	.1875	2.0	EMS-187-4	23.00	EMS-187-4X	25.90
.2187	.2187	.2187	.625	3	.2500	2.5	EMS-218-3	28.90	EMS-218-3X	33.80
6 mm	.2362		18 mm	2	6 mm	57 mm			EMSM-060-2X	28.90
6 mm	.2362		18 mm	4	6 mm	57 mm	EMSM-060-4	24.00	EMSM-060-4X	28.90
.2500	.2500	.2500	.750	2	.2500	2.5	EMS-250-2	28.90		
.2500	.2500	.2500	.750	3	.2500	2.5	EMS-250-3	28.90	EMS-250-3X	33.80
.2500	.2500	.2500	.750	4	.2500	2.5	EMS-250-4	28.90	EMS-250-4X	33.80
.2810	.2810	.2810	.750	2	.3125	2.5			EMS-281-2X	40.40

\*.0005" / .013 mm max TIR

Continued on next page

# End Mills – Square

EMS / EMSM

2, 3, 4, 6 Flute – NC Tolerance (cont.)

Continued from previous page

End Mills

Cutter Diameter*			Length of Cut	Flutes	Shank Diameter	Overall Length	Uncoated		AlTiN Coated	
D1 +.0010" -.0000"	+.03 mm -.00 mm	decimal equiv.	L2 +.030" -.000" +.78 mm -.00 mm	D2 (h6)	L1	Tool #	Price	Tool #	Price	
										.3125
	8 mm	.3150	22 mm	3	8 mm	63 mm	EMSM-080-3	29.55		
.3750	.3750	.3750	.875	2	.3750	2.5	EMS-375-2	38.10	EMS-375-2X	44.90
.3750	.3750	.3750	.875	3	.3750	2.5	EMS-375-3	38.10	EMS-375-3X	44.90
.3750	.3750	.3750	.875	4	.3750	2.5	EMS-375-4	38.10	EMS-375-4X	44.90
	10 mm	.3937	25 mm	3	10 mm	72 mm	EMSM-100-3	34.85		
.4375	.4375	.4375	1.000	2	.4375	2.5	EMS-437-2	60.10	EMS-437-2X	68.30
	12 mm	.4724	30 mm	3	12 mm	83 mm	EMSM-120-3	55.55		
.5000	.5000	.5000	1.000	2	.5000	3.0	EMS-500-2	66.00	EMS-500-2X	74.20
.5000	.5000	.5000	1.000	3	.5000	3.0	EMS-500-3	66.00	EMS-500-3X	74.20
.5000	.5000	.5000	1.000	4	.5000	3.0	EMS-500-4	66.00	EMS-500-4X	74.20
	14 mm	.5512	35 mm	4	14 mm	83 mm	EMSM-140-4	64.55		
.6250	.6250	.6250	1.250	4	.6250	3.5	EMS-625-4	116.75		
	16 mm	.6299	35 mm	3	16 mm	92 mm	EMSM-160-3	102.95		
.6875	.6875	.6875	1.375	3	.6875	4.0	EMS-687-3	143.80	EMS-687-3X	158.10
.7500	.7500	.7500	1.500	2	.7500	4.0	EMS-750-2	178.00		
.7500	.7500	.7500	1.500	4	.7500	4.0	EMS-750-4	178.00		
	20 mm	.7874	45 mm	3	20 mm	104 mm	EMSM-200-3	175.75		
	20 mm	.7874	45 mm	4	20 mm	104 mm	EMSM-200-4	175.75		
1.0000	1.0000	1.0000	2.500	3	1.0000	5.0	EMS-001-3	269.60		
1.0000	1.0000	1.0000	2.500	6	1.0000	5.0	EMS-001-6	269.60		

\*.0005" / .013 mm max TIR



## TSM

## End Mills – Square

### 3 Flute – Tapered End Mill

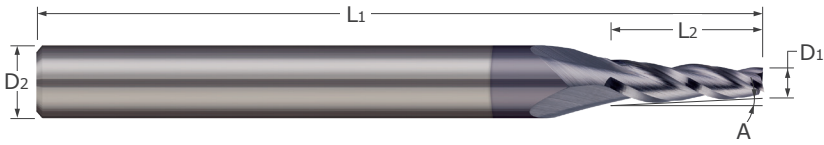

- Designed to machine tapered profiles in cavities
- Well suited for die and mold making applications
- Available in standard and long length styles
- 30° helix ■ Center cutting
- AlTiN coating option for added lubricity and increased wear resistance in difficult-to-machine materials
- Solid carbide
- CNC ground in the USA

Angle Per Side	Cutter Diameter*	Length of Cut	Flutes	Shank Diameter	Overall Length	Uncoated		AlTiN Coated	
						Tool #	Price	Tool #	Price
A $+0^{\circ}30'$ $-0^{\circ}30'$	D1 $+.0030''$ $-.0000''$	L2		D2 (h6)	L1				
1°	.1875	.750	3	.3750	2.5	TSM-375-0	65.55		
1° 30'	.1250	.500	3	.2500	2.5	TSM-250-1	43.05		
3°	.1250	.500	3	.2500	2.5	TSM-250-3	43.05	TSM-250-3X	47.95
	.1562	.750	3	.3750	2.5	TSM-375-3	65.55		
5°	.1250	.500	3	.2500	2.5	TSM-250-5	43.05		
	.1250	.750	3	.3750	2.5	TSM-375-5	65.55		
7°	.1250	.500	3	.2500	2.5	TSM-250-7	43.05		

\*.0005" / .013 mm max TIR

# End Mills – Ball

## 2, 3, 4 Flute – Stub & Standard

**BMR / BMRM / BMS  
BMSM / BEM / BEMM**

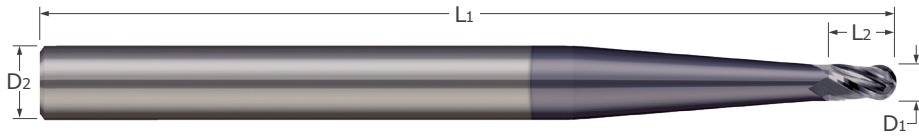

End Mills

- Designed for general purpose machining
- 30° helix ■ Center cutting
- Ball profile
- AlTiN coating option for added lubricity and increased wear resistance in difficult-to-machine materials
- Solid carbide
- CNC ground in the USA

Cutter Diameter*			Length of Cut	Flutes	Shank Diameter	Overall Length	Uncoated		AlTiN Coated	
D1 +.0005" -.0005"	+.00 mm -.02 mm	decimal equiv.	L2	D2 (h6)	L1	Tool #	Price	Tool #	Price	
										.0100
.0100	.0100	.0100	.030	2	.1250	1.5	BMR-010-2	40.15	BMR-010-2X	42.65
.0110	.0110	.0110	.033	2	.1250	1.5	BMR-011-2	36.45	BMR-011-2X	38.95
0.3 mm		.0118	0.5 mm	2	3 mm	38 mm	BMSM-003-2	28.95	BMSM-003-2X	31.45
.0120	.0120	.0120	.018	2	.1250	1.5	BMS-012-2	34.75	BMS-012-2X	37.25
.0120	.0120	.0120	.036	2	.1250	1.5	BMR-012-2	36.45	BMR-012-2X	38.95
.0130	.0130	.0130	.019	2	.1250	1.5	BMS-013-2	29.55	BMS-013-2X	32.05
.0130	.0130	.0130	.039	2	.1250	1.5	BMR-013-2	31.00	BMR-013-2X	33.50
.0140	.0140	.0140	.021	2	.1250	1.5	BMS-014-2	29.55	BMS-014-2X	32.05
.0140	.0140	.0140	.042	2	.1250	1.5	BMR-014-2	31.00	BMR-014-2X	33.50
.0150	.0150	.0150	.022	2	.1250	1.5	BMS-015-2	23.60	BMS-015-2X	26.10
.0150	.0150	.0150	.045	2	.1250	1.5	BMR-015-2	24.50	BMR-015-2X	27.00
0.4 mm		.0157	0.6 mm	2	3 mm	38 mm	BMSM-004-2	21.40	BMSM-004-2X	23.90
.0160	.0160	.0160	.024	2	.1250	1.5	BMS-016-2	23.60	BMS-016-2X	26.10
.0160	.0160	.0160	.048	2	.1250	1.5	BMR-016-2	24.50	BMR-016-2X	27.00
.0170	.0170	.0170	.051	2	.1250	1.5	BMR-017-2	24.50	BMR-017-2X	27.00
.0180	.0180	.0180	.027	2	.1250	1.5	BMS-018-2	23.60	BMS-018-2X	26.10
.0180	.0180	.0180	.054	2	.1250	1.5	BMR-018-2	24.50	BMR-018-2X	27.00
.0190	.0190	.0190	.028	2	.1250	1.5	BMS-019-2	23.60	BMS-019-2X	26.10
.0190	.0190	.0190	.057	2	.1250	1.5	BMR-019-2	24.50	BMR-019-2X	27.00
0.5 mm		.0197	0.8 mm	2	3 mm	38 mm	BMSM-005-2	19.75	BMSM-005-2X	22.25
0.5 mm		.0197	1.5 mm	2	4 mm	50 mm	BMRM-005-2	21.60	BMRM-005-2X	24.50
.0200	.0200	.0200	.030	2	.1250	1.5	BMS-020-2	21.70	BMS-020-2X	24.20
.0200	.0200	.0200	.060	2	.1250	1.5	BMR-020-2	22.75	BMR-020-2X	25.25
.0210	.0210	.0210	.063	2	.1250	1.5	BMR-021-2	22.75		
.0220	.0220	.0220	.033	2	.1250	1.5			BMS-022-2X	24.20
.0220	.0220	.0220	.066	2	.1250	1.5	BMR-022-2	22.75	BMR-022-2X	25.25
.0230	.0230	.0230	.034	2	.1250	1.5	BMS-023-2	21.70	BMS-023-2X	24.20
.0230	.0230	.0230	.069	2	.1250	1.5	BMR-023-2	22.75	BMR-023-2X	25.25
0.6 mm		.0236	0.9 mm	2	3 mm	38 mm	BMSM-006-2	19.75	BMSM-006-2X	22.25
0.6 mm		.0236	1.8 mm	2	4 mm	50 mm	BMRM-006-2	21.60	BMRM-006-2X	24.50

\*.0005" / .013 mm max TIR

Continued on next page

**BMR / BMRM / BMS  
BMSM / BEM / BEMM**

**End Mills – Ball**  
2, 3, 4 Flute – Stub & Standard (cont.)

Continued from previous page

Cutter Diameter*			Length of Cut	Flutes	Shank Diameter	Overall Length	Uncoated		AITIN Coated	
D1			L2		D2 (h6)	L1	Tool #	Price	Tool #	Price
+.0005" -.0005"	+ .00 mm -.02 mm	decimal equiv.								
.0240		.0240	.072	2	.1250	1.5	BMR-024-2	22.75	BMR-024-2X	25.25
.0250		.0250	.037	2	.1250	1.5	BMS-025-2	21.70	BMS-025-2X	24.20
.0250		.0250	.075	2	.1250	1.5	BMR-025-2	22.75	BMR-025-2X	25.25
.0260		.0260	.039	2	.1250	1.5			BMS-026-2X	22.25
.0260		.0260	.078	2	.1250	1.5	BMR-026-2	20.70	BMR-026-2X	23.20
.0270		.0270	.081	2	.1250	1.5	BMR-027-2	20.70	BMR-027-2X	23.20
	0.7 mm	.0276	1.1 mm	2	3 mm	38 mm	BMSM-007-2	18.80	BMSM-007-2X	21.30
	0.7 mm	.0276	2.1 mm	2	4 mm	50 mm	BMRM-007-2	21.60	BMRM-007-2X	24.50
.0280		.0280	.042	2	.1250	1.5	BMS-028-2	19.75	BMS-028-2X	22.25
.0280		.0280	.084	2	.1250	1.5	BMR-028-2	20.70	BMR-028-2X	23.20
.0300		.0300	.045	2	.1250	1.5	BMS-030-2	19.75	BMS-030-2X	22.25
.0300		.0300	.090	2	.1250	1.5	BMR-030-2	20.70	BMR-030-2X	23.20
.0310		.0310	.047	2	.1250	1.5	BMS-031-2	19.75	BMS-031-2X	22.25
.0310		.0310	.093	2	.1250	1.5	BMR-031-2	20.70	BMR-031-2X	23.20

D1			L2		D2 (h6)	L1	Tool #	Price	Tool #	Price
+.0000" -.0020"	+ .00 mm -.02 mm	decimal equiv.								
.0313		.0313	.078	2	.1250	1.5	BEM-031-02	17.20	BEM-031-02X	19.70
.0313		.0313	.078	3	.1250	1.5	BEM-031-03	17.20	BEM-031-03X	19.70
.0313		.0313	.078	4	.1250	1.5	BEM-031-04	17.20	BEM-031-04X	19.70
	0.8 mm	.0315	1.2 mm	2	3 mm	38 mm	BMSM-008-2	18.80	BMSM-008-2X	21.30
	0.8 mm	.0315	2.4 mm	2	4 mm	50 mm	BMRM-008-2	21.60	BMRM-008-2X	24.50
.0320		.0320	.048	2	.1250	1.5	BMS-032-2	19.75	BMS-032-2X	22.25
.0320		.0320	.096	2	.1250	1.5	BMR-032-2	20.70	BMR-032-2X	23.20
.0330		.0330	.050	2	.1250	1.5	BMS-033-2	19.75	BMS-033-2X	22.25
.0330		.0330	.099	2	.1250	1.5	BMR-033-2	20.70	BMR-033-2X	23.20
.0340		.0340	.051	2	.1250	1.5	BMS-034-2	19.75	BMS-034-2X	22.25
.0350		.0350	.053	2	.1250	1.5	BMS-035-2	19.75	BMS-035-2X	22.25
.0350		.0350	.105	2	.1250	1.5	BMR-035-2	20.70	BMR-035-2X	23.20
	0.9 mm	.0354	1.4 mm	2	3 mm	38 mm	BMSM-009-2	18.80	BMSM-009-2X	21.30
	0.9 mm	.0354	2.7 mm	2	4 mm	50 mm	BMRM-009-2	21.60	BMRM-009-2X	24.50
	1 mm	.0394	1.5 mm	2	3 mm	38 mm	BMSM-010-2	18.35	BMSM-010-2X	20.85
	1 mm	.0394	1.5 mm	4	3 mm	38 mm	BMSM-010-4	18.35	BMSM-010-4X	20.85
	1 mm	.0394	3 mm	2	4 mm	50 mm	BMRM-010-2	19.85	BMRM-010-2X	22.75
	1 mm	.0394	3 mm	4	4 mm	50 mm			BMRM-010-4X	22.75
.0400		.0400	.060	2	.1250	1.5	BMS-040-2	19.75	BMS-040-2X	22.25
.0400		.0400	.120	2	.1250	1.5	BMR-040-2	20.70	BMR-040-2X	23.20
	1.1 mm	.0433	3.3 mm	2	4 mm	50 mm	BMRM-011-2	19.85	BMRM-011-2X	22.75
	1.1 mm	.0433	3.3 mm	4	4 mm	50 mm	BMRM-011-4	19.85	BMRM-011-4X	22.75
.0450		.0450	.135	2	.1250	1.5	BMR-045-2	20.70	BMR-045-2X	23.20
.0468		.0468	.109	2	.1250	1.5	BEM-046-02	17.20	BEM-046-02X	19.70
.0468		.0468	.109	3	.1250	1.5	BEM-046-03	17.20	BEM-046-03X	19.70
.0468		.0468	.109	4	.1250	1.5	BEM-046-04	17.20	BEM-046-04X	19.70

\*.0005" / .013 mm max TIR

Continued on next page

# End Mills – Ball

## 2, 3, 4 Flute – Stub & Standard (cont.)

**BMR / BMRM / BMS  
BMSM / BEM / BEMM**

Continued from previous page

End Mills

Cutter Diameter*			Length of Cut	Flutes	Shank Diameter	Overall Length	Uncoated		AITIN Coated	
D1 +.0000" -.0020"	+.00 mm -.02 mm	decimal equiv.	L2	D2 (h6)	L1	Tool #	Price	Tool #	Price	
										.0500
.0500	.0500	.0500	.150	2	.1250	1.5	BMR-050-2	20.70	BMR-050-2X	23.20
1.4 mm	.0551	.0551	2.1 mm	2	3 mm	38 mm	BMSM-014-2	18.35	BMSM-014-2X	20.85
1.5 mm	.0591	.0591	2.3 mm	2	3 mm	38 mm	BMSM-015-2	18.35	BMSM-015-2X	20.85
1.5 mm	.0591	.0591	4.2 mm	2	4 mm	50 mm	BMRM-015-2	19.85	BMRM-015-2X	22.75
1.5 mm	.0591	.0591	4.2 mm	4	4 mm	50 mm	BMRM-015-4	19.85	BMRM-015-4X	22.75
.0625	.0625	.0625	.188	2	.1250	1.5	BEM-062-02	15.50	BEM-062-02X	18.00
.0625	.0625	.0625	.188	3	.1250	1.5	BEM-062-03	15.50	BEM-062-03X	18.00
.0625	.0625	.0625	.188	4	.1250	1.5	BEM-062-04	15.50	BEM-062-04X	18.00
1.6 mm	.0630	.0630	2.4 mm	2	3 mm	38 mm	BMSM-016-2	16.90	BMSM-016-2X	19.40
1.6 mm	.0630	.0630	4.8 mm	2	4 mm	50 mm	BMRM-016-2	19.85	BMRM-016-2X	22.75
1.7 mm	.0669	.0669	2.5 mm	4	3 mm	38 mm			BMSM-017-4X	19.40
1.8 mm	.0709	.0709	2.7 mm	2	3 mm	38 mm	BMSM-018-2	16.90	BMSM-018-2X	19.40
1.8 mm	.0709	.0709	2.7 mm	4	3 mm	38 mm			BMSM-018-4X	19.40
1.8 mm	.0709	.0709	5.3 mm	2	4 mm	50 mm			BMRM-018-2X	22.75
1.8 mm	.0709	.0709	5.3 mm	4	4 mm	50 mm			BMRM-018-4X	22.75
1.9 mm	.0748	.0748	2.8 mm	2	3 mm	38 mm	BMSM-019-2	16.90	BMSM-019-2X	19.40
1.9 mm	.0748	.0748	2.8 mm	4	3 mm	38 mm	BMSM-019-4	16.90	BMSM-019-4X	19.40
.0781	.0781	.0781	.188	2	.1250	1.5	BEM-078-02	15.50	BEM-078-02X	18.00
.0781	.0781	.0781	.188	3	.1250	1.5	BEM-078-03	15.50	BEM-078-03X	18.00
.0781	.0781	.0781	.188	4	.1250	1.5	BEM-078-04	15.50	BEM-078-04X	18.00
2 mm	.0787	.0787	3 mm	2	3 mm	38 mm	BMSM-020-2	16.90	BMSM-020-2X	19.40
2 mm	.0787	.0787	3 mm	4	3 mm	38 mm			BMSM-020-4X	19.40
2 mm	.0787	.0787	6 mm	2	4 mm	50 mm	BMRM-020-2	19.85	BMRM-020-2X	22.75
2 mm	.0787	.0787	6 mm	4	4 mm	50 mm			BMRM-020-4X	22.75
.0937	.0937	.0937	.375	2	.1250	1.5	BEM-093-02	15.50	BEM-093-02X	18.00
.0937	.0937	.0937	.375	3	.1250	1.5	BEM-093-03	15.50	BEM-093-03X	18.00
.0937	.0937	.0937	.375	4	.1250	1.5	BEM-093-04	15.50	BEM-093-04X	18.00
2.5 mm	.0984	.0984	3.8 mm	2	3 mm	38 mm	BMSM-025-2	16.90	BMSM-025-2X	19.40
2.5 mm	.0984	.0984	3.8 mm	4	3 mm	38 mm	BMSM-025-4	16.90	BMSM-025-4X	19.40
.1093	.1093	.1093	.375	2	.1250	1.5	BEM-109-02	15.50		
3 mm	.1181	.1181	15 mm	2	3 mm	38 mm	BEMM-030-2	12.75	BEMM-030-2X	15.25
3 mm	.1181	.1181	15 mm	3	3 mm	38 mm	BEMM-030-3	12.75	BEMM-030-3X	15.25
3 mm	.1181	.1181	15 mm	4	3 mm	38 mm	BEMM-030-4	12.75	BEMM-030-4X	15.25
3 mm	.1181	.1181	9 mm	2	4 mm	50 mm	BMRM-030-2	19.85	BMRM-030-2X	22.75
3 mm	.1181	.1181	9 mm	4	4 mm	50 mm			BMRM-030-4X	22.75
.1250	.1250	.1250	.500	2	.1250	1.5	BEM-125-02	13.90	BEM-125-02X	16.40
.1250	.1250	.1250	.500	3	.1250	1.5	BEM-125-03	13.90	BEM-125-03X	16.40
.1250	.1250	.1250	.500	4	.1250	1.5	BEM-125-04	13.90	BEM-125-04X	16.40
3.5 mm	.1378	.1378	10.5 mm	2	4 mm	50 mm	BMRM-035-2	19.85	BMRM-035-2X	22.75

\*.0005" / .013 mm max TIR

Continued on next page

**BMR / BMRM / BMS  
BMSM / BEM / BEMM**
**End Mills – Ball**  
 2, 3, 4 Flute – Stub & Standard (cont.)

Continued from previous page

Cutter Diameter*			Length of Cut	Flutes	Shank Diameter	Overall Length	Uncoated		AlTiN Coated	
D1							L2	D2 (h6)	L1	Tool #
+ .0000" - .0020"	+ .00 mm - .02 mm	decimal equiv.								
.1562		.1562	.563	2	.1875	2.0	BEM-156-02	22.05	BEM-156-02X	24.95
.1562		.1562	.563	3	.1875	2.0	BEM-156-03	22.05	BEM-156-03X	24.95
.1562		.1562	.563	4	.1875	2.0	BEM-156-04	22.05	BEM-156-04X	24.95
	4 mm	.1575	18 mm	2	4 mm	50 mm	BEMM-040-2	19.05	BEMM-040-2X	21.95
	4 mm	.1575	18 mm	3	4 mm	50 mm	BEMM-040-3	19.05	BEMM-040-3X	21.95
	4 mm	.1575	18 mm	4	4 mm	50 mm	BEMM-040-4	19.05	BEMM-040-4X	21.95
.1719		.1719	.625	2	.1875	2.0	BEM-171-02	22.05	BEM-171-02X	24.95
.1875		.1875	.625	2	.1875	2.0	BEM-187-02	22.05	BEM-187-02X	24.95
.1875		.1875	.625	3	.1875	2.0	BEM-187-03	22.05	BEM-187-03X	24.95
.1875		.1875	.625	4	.1875	2.0	BEM-187-04	22.05	BEM-187-04X	24.95
	5 mm	.1969	18 mm	3	6 mm	50 mm	BEMM-050-3	20.30		
.2031		.2031	.625	3	.2500	2.5			BEM-203-03X	32.55
.2187		.2187	.625	2	.2500	2.5	BEM-218-02	27.65	BEM-218-02X	32.55
.2187		.2187	.625	4	.2500	2.5	BEM-218-04	27.65	BEM-218-04X	32.55
.2343		.2343	.750	2	.2500	2.5			BEM-234-02X	32.55
.2343		.2343	.750	3	.2500	2.5	BEM-234-03	27.65		
	6 mm	.2362	18 mm	2	6 mm	57 mm	BEMM-060-2	24.00	BEMM-060-2X	28.90
	6 mm	.2362	18 mm	4	6 mm	57 mm	BEMM-060-4	24.00	BEMM-060-4X	28.90
.2500		.2500	.750	2	.2500	2.5	BEM-250-02	27.65	BEM-250-02X	32.55
.2500		.2500	.750	3	.2500	2.5	BEM-250-03	27.65	BEM-250-03X	32.55
.2500		.2500	.750	4	.2500	2.5	BEM-250-04	27.65	BEM-250-04X	32.55
.2812		.2812	.750	2	.3125	2.5			BEM-281-02X	39.00
.2812		.2812	.750	4	.3125	2.5	BEM-281-04	32.20	BEM-281-04X	39.00
.3125		.3125	.813	2	.3125	2.5	BEM-312-02	32.20	BEM-312-02X	39.00
.3125		.3125	.813	4	.3125	2.5	BEM-312-04	32.20	BEM-312-04X	39.00
	8 mm	.3150	22 mm	2	8 mm	63 mm	BEMM-080-2	29.55	BEMM-080-2X	36.35
	8 mm	.3150	22 mm	3	8 mm	63 mm	BEMM-080-3	29.55		
	8 mm	.3150	22 mm	4	8 mm	63 mm	BEMM-080-4	29.55	BEMM-080-4X	36.35
.3750		.3750	.875	2	.3750	2.5	BEM-375-02	36.55	BEM-375-02X	43.35
.3750		.3750	.875	3	.3750	2.5	BEM-375-03	36.55	BEM-375-03X	43.35
.3750		.3750	.875	4	.3750	2.5	BEM-375-04	36.55	BEM-375-04X	43.35
	10 mm	.3937	25 mm	2	10 mm	72 mm	BEMM-100-2	34.85	BEMM-100-2X	41.65
	10 mm	.3937	25 mm	3	10 mm	72 mm	BEMM-100-3	34.85	BEMM-100-3X	41.65
	10 mm	.3937	25 mm	4	10 mm	72 mm	BEMM-100-4	34.85	BEMM-100-4X	41.65
.4370		.4370	1.000	2	.4375	2.5			BEM-437-02X	65.90
	12 mm	.4724	30 mm	3	12 mm	83 mm			BEMM-120-3X	65.85
	12 mm	.4724	30 mm	4	12 mm	83 mm	BEMM-120-4	55.55	BEMM-120-4X	65.85
.5000		.5000	1.000	2	.5000	3.0	BEM-500-02	63.25	BEM-500-02X	71.45
.5000		.5000	1.000	3	.5000	3.0	BEM-500-03	63.25	BEM-500-03X	71.45
.5000		.5000	1.000	4	.5000	3.0	BEM-500-04	63.25	BEM-500-04X	71.45
.5625		.5625	1.250	2	.5625	3.5			BEM-562-02X	105.60

\*.0005" / .013 mm max TIR

Continued on next page

## End Mills – Ball 2, 3, 4 Flute – Stub & Standard (cont.)

**BMR / BMRM / BMS  
BMSM / BEM / BEMM**

Continued from previous page

End Mills

Cutter Diameter*			Length of Cut	Flutes	Shank Diameter	Overall Length	Uncoated		AlTiN Coated	
D1			L2		D2 (h6)	L1	Tool #	Price	Tool #	Price
+ .0000" - .0020"	+ .00 mm - .02 mm	decimal equiv.								
.6250		.6250	1.250	4	.6250	3.5	BEM-625-04	111.85	BEM-625-04X	124.25
	16 mm	.6299	35 mm	3	16 mm	92 mm			BEMM-160-3X	115.35
.6875		.6875	1.375	2	.7500	4.0			BEM-687-02X	152.00
.6875		.6875	1.375	2	.7500	4.0	BEM-687-02	137.70		
.6875		.6875	1.375	3	.7500	4.0	BEM-687-03	137.70		
.6875		.6875	1.375	4	.7500	4.0	BEM-687-04	137.70		
	18 mm	.7087	45 mm	2	18 mm	92 mm	BEMM-180-2	138.30	BEMM-180-2X	152.60
.7500		.7500	1.500	2	.7500	4.0	BEM-750-02	170.65		
.7500		.7500	1.500	4	.7500	4.0			BEM-750-04X	184.95
	20 mm	.7874	45 mm	2	20 mm	104 mm			BEMM-200-2X	195.75
	20 mm	.7874	45 mm	4	20 mm	104 mm	BEMM-200-4	175.75		
.8750		.8750	1.500	2	.8750	4.0	BEM-875-02	236.40		
1.0000		1.0000	1.500	3	1.0000	4.0	BEM-001-03	258.45		

\*.0005" / .013 mm max TIR

## BEL / BELM

## End Mills – Ball

### 2, 3, 4 Flute – Long Flute

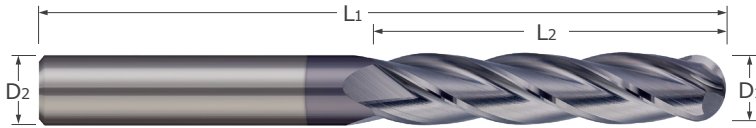

- Long reach for deep pocket milling and long length peripheral milling
- 30° helix ■ Center cutting
- Ball profile
- AlTiN coating option for added lubricity and increased wear resistance in difficult-to-machine materials
- Solid carbide
- CNC ground in the USA

Cutter Diameter*		Length of Cut L2	Flutes	Shank Diameter D2 (h6)	Overall Length L1	Uncoated		AlTiN Coated	
D1 +.0000" -.0020" (h9)	decimal equiv.					Tool #	Price	Tool #	Price
		+.031" -.000" +.79 mm -.00 mm							
3 mm	.1181	25 mm	2	3 mm	75 mm	BELM-030-2	21.40		
6 mm	.2362	25 mm	4	6 mm	75 mm			BELM-060-4X	39.80
10 mm	.3937	38 mm	2	10 mm	100 mm			BELM-100-2X	59.15
10 mm	.3937	38 mm	3	10 mm	100 mm	BELM-100-3	50.75		
10 mm	.3937	38 mm	4	10 mm	100 mm	BELM-100-4	50.75		

D1 +.0000" -.0030" (h9)	decimal equiv.	L2	Flutes	D2 (h6)	L1	Tool #	Price	Tool #	Price
.4375	.4375	3.000	4	.4375	6.0	BEL-437-4	77.80		
12 mm	.4724	50 mm	3	12 mm	100 mm	BELM-120-3	74.10	BELM-120-3X	84.40
12 mm	.4724	50 mm	4	12 mm	100 mm	BELM-120-4	74.10		
14 mm	.5512	75 mm	4	14 mm	150 mm	BELM-140-4	110.45		
18 mm	.7087	75 mm	4	18 mm	150 mm	BELM-180-4	186.00		
20 mm	.7874	75 mm	2	20 mm	150 mm	BELM-200-2	251.50		
20 mm	.7874	75 mm	4	20 mm	150 mm			BELM-200-4X	276.60
25 mm	.9843	75 mm	2	25 mm	150 mm	BELM-250-2	295.20	BELM-250-2X	320.30
25 mm	.9843	75 mm	4	25 mm	150 mm	BELM-250-4	295.20	BELM-250-4X	320.30

\*.0005" / .013 mm max TIR

# End Mills – Ball

## 2, 3, 4 Flute – Reduced Neck

**BLR / BLRM**  
**SFBM / MMBM**

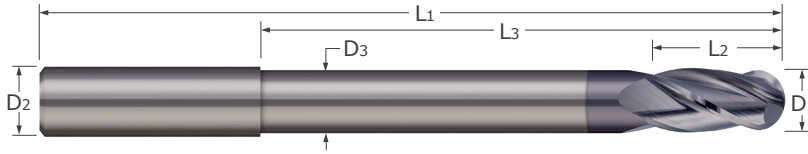

End Mills

- Long reach for deep pocket milling
- SFBM and MMBM manufactured to improved cutter diameter tolerance (h8) for mold making
- 30° helix ■ Center cutting
- Ball profile
- AlTiN coating option for added lubricity and increased wear resistance in difficult-to-machine materials
- Solid carbide
- CNC ground in the USA

Cutter Diameter*		Length of Cut	Overall Reach	Neck Dia.	Flutes	Shank Dia.	Overall Length	Uncoated		AlTiN Coated	
D1	decimal equiv.	L2	L3	D3		D2 (h6)	L1	Tool #	Price	Tool #	Price
$+0.0000$ $-0.0020$	(h6)	$+0.015$ $-0.000$	$+0.015$ $-0.015$								
		$+0.38$ $-0.00$ mm	$+0.38$ $-0.38$ mm								
0.2 mm	.0078	0.3 mm	0.3 mm	-	2	6 mm	57 mm	SFBM-002-0	61.60	SFBM-002-0X	66.50
0.3 mm	.0118	0.3 mm	3.0 mm	0.28 mm	2	4 mm	50 mm	MMBM-003-3	46.85	MMBM-003-3X	49.75
0.3 mm	.0118	0.4 mm	0.4 mm	0.4 mm	2	6 mm	57 mm			SFBM-003-0X	59.25
0.3 mm	.0118	0.4 mm	1.0 mm	0.25 mm	2	6 mm	57 mm	SFBM-003-1	54.35		
0.4 mm	.0157	0.4 mm	3.0 mm	0.38 mm	2	4 mm	50 mm	MMBM-004-3	40.30	MMBM-004-3X	43.20
0.4 mm	.0157	0.4 mm	8.0 mm	0.38 mm	2	4 mm	50 mm	MMBM-004-8	40.30	MMBM-004-8X	43.20
0.4 mm	.0157	0.5 mm	1.2 mm	0.5 mm	2	6 mm	57 mm			SFBM-004-1X	57.85
0.5 mm	.0197	0.5 mm	5.0 mm	0.48 mm	2	4 mm	50 mm	MMBM-005-5	35.50	MMBM-005-5X	38.40
0.5 mm	.0197	0.5 mm	5.0 mm	0.5 mm	2	6 mm	57 mm	SFBM-005-5	52.95		
0.5 mm	.0197	0.5 mm	10.0 mm	0.48 mm	2	4 mm	50 mm	MMBM-005-10	35.50	MMBM-005-10X	38.40
0.5 mm	.0197	0.6 mm	1.6 mm	0.45 mm	2	6 mm	57 mm			SFBM-005-1X	55.35
0.6 mm	.0236	0.6 mm	12.0 mm	0.58 mm	2	4 mm	50 mm			MMBM-006-12X	38.40
0.6 mm	.0236	0.6 mm	5.0 mm	0.58 mm	2	4 mm	50 mm	MMBM-006-5	35.50	MMBM-006-5X	38.40
0.7 mm	.0276	0.7 mm	5.0 mm	0.68 mm	2	4 mm	50 mm	MMBM-007-5	35.50		
0.8 mm	.0315	0.8 mm	2.5 mm	0.8 mm	2	6 mm	57 mm			SFBM-008-2X	53.00
0.8 mm	.0315	0.8 mm	5.0 mm	0.78 mm	2	4 mm	50 mm	MMBM-008-5	30.50	MMBM-008-5X	33.40
0.8 mm	.0315	0.8 mm	5.2 mm	0.75 mm	2	6 mm	57 mm			SFBM-008-5X	53.00
0.8 mm	.0315	0.8 mm	8.0 mm	0.75 mm	2	6 mm	57 mm	SFBM-008-8	52.60	SFBM-008-8X	57.50
0.8 mm	.0315	0.8 mm	10.0 mm	0.78 mm	2	4 mm	50 mm	MMBM-008-10	30.50		
1.0 mm	.0394	1.3 mm	3.3 mm	0.95 mm	2	6 mm	57 mm			SFBM-010-3X	50.55
1.0 mm	.0394	1.0 mm	6.0 mm	0.95 mm	2	6 mm	57 mm	MMBM-010-6	33.45	MMBM-010-6X	38.35
1.0 mm	.0394	1.0 mm	8.0 mm	0.95 mm	2	6 mm	57 mm			MMBM-010-8X	38.35
1.0 mm	.0394	1.0 mm	11.0 mm	0.95 mm	2	6 mm	57 mm	MMBM-010-11	33.45	MMBM-010-11X	38.35
1.0 mm	.0394	1.0 mm	12.0 mm	1.0 mm	2	6 mm	57 mm			MMBM-010-12X	38.35
1.0 mm	.0394	1.0 mm	15.0 mm	0.95 mm	2	6 mm	57 mm			MMBM-010-15X	38.35
1.0 mm	.0394	1.0 mm	20.0 mm	0.95 mm	2	6 mm	57 mm	MMBM-010-20	33.45	MMBM-010-20X	38.35
1.2 mm	.0472	1.5 mm	3.5 mm	1.15 mm	2	6 mm	57 mm	SFBM-012-3	43.45		
1.2 mm	.0472	1.2 mm	7.0 mm	1.15 mm	2	6 mm	57 mm			MMBM-012-7X	38.35
1.2 mm	.0472	1.2 mm	15.0 mm	1.15 mm	2	6 mm	57 mm	MMBM-012-15	33.45	MMBM-012-15X	38.35
1.2 mm	.0472	1.2 mm	20.0 mm	1.15 mm	2	6 mm	57 mm	MMBM-012-20	33.45		

\*.0005" / .013 mm max TIR. SFBM and MMBM tools held to h8 tolerance

Continued on next page



**BLR / BLRM  
SFBM / MMBM**

**End Mills – Ball**  
2, 3, 4 Flute – Reduced Neck (cont.)

Continued from previous page

Cutter Diameter*			Length of Cut	Overall Reach	Neck Dia.	Flutes	Shank Dia.	Overall Length	Uncoated		AITiN Coated	
D1 +.0000" -.0020" (h6) decimal equiv.	L2	L3	D3	D2 (h6)	L1	Tool #	Price	Tool #	Price			
1.5 mm .0591	1.5 mm	7.0 mm	1.45 mm	2	6 mm	57 mm	MMBM-015-7	33.45	MMBM-015-7X	38.35		
1.5 mm .0591	1.5 mm	9.5 mm	1.45 mm	2	6 mm	57 mm	SFBM-015-9	43.40	SFBM-015-9X	48.30		
1.5 mm .0591	1.5 mm	15.0 mm	1.45 mm	2	6 mm	57 mm	MMBM-015-15	33.45	MMBM-015-15X	38.35		
1.5 mm .0591	1.5 mm	20.0 mm	1.45 mm	2	6 mm	57 mm			MMBM-015-20X	38.35		
2.0 mm .0787	2.0 mm	7.0 mm	1.9 mm	2	6 mm	57 mm	MMBM-020-7	33.45	MMBM-020-7X	38.35		
2.0 mm .0787	2.0 mm	15.0 mm	1.9 mm	2	6 mm	57 mm	MMBM-020-15	33.45	MMBM-020-15X	38.35		
2.0 mm .0787	2.0 mm	20.0 mm	1.9 mm	2	6 mm	57 mm	MMBM-020-20	33.45	MMBM-020-20X	38.35		
2.0 mm .0787	2.5 mm	9.5 mm	1.95 mm	2	6 mm	57 mm	SFBM-020-9	41.75	SFBM-020-9X	46.65		
2.0 mm .0787	5.0 mm	15.0 mm	1.5 mm	2	6 mm	57 mm			BLRM-020-2X	33.30		
2.0 mm .0787	5.0 mm	15.0 mm	1.5 mm	4	6 mm	57 mm			BLRM-020-4X	33.30		
3.0 mm .1181	3.0 mm	12.0 mm	2.9 mm	2	6 mm	57 mm	MMBM-030-12	33.45	MMBM-030-12X	38.35		
3.0 mm .1181	3.0 mm	15.0 mm	2.9 mm	2	6 mm	57 mm	MMBM-030-15	33.45	MMBM-030-15X	38.35		
3.0 mm .1181	4.0 mm	8.0 mm	2.9 mm	2	6 mm	57 mm	SFBM-030-8	37.35	SFBM-030-8X	42.25		
3.0 mm .1181	4.0 mm	15.0 mm	2.9 mm	2	6 mm	57 mm	SFBM-030-15	40.05	SFBM-030-15X	44.95		
3.0 mm .1181	8.0 mm	30.0 mm	2.5 mm	2	6 mm	75 mm	BLRM-030-2	30.05	BLRM-030-2X	34.95		
3.0 mm .1181	8.0 mm	30.0 mm	2.5 mm	4	6 mm	75 mm	BLRM-030-4	30.05	BLRM-030-4X	34.95		
4.0 mm .1575	4.0 mm	15.0 mm	3.8 mm	2	6 mm	57 mm	MMBM-040-15	33.45	MMBM-040-15X	38.35		
4.0 mm .1575	5.0 mm	10.0 mm	5.0 mm	2	6 mm	57 mm			SFBM-040-10X	42.25		
4.0 mm .1575	5.0 mm	20.0 mm	3.9 mm	2	6 mm	57 mm	SFBM-040-20	41.75	SFBM-040-20X	46.65		
4.0 mm .1575	8.0 mm	30.0 mm	3.5 mm	2	6 mm	75 mm	BLRM-040-2	30.05	BLRM-040-2X	34.95		
4.0 mm .1575	8.0 mm	30.0 mm	3.5 mm	3	6 mm	75 mm	BLRM-040-3	30.05				
4.0 mm .1575	8.0 mm	30.0 mm	3.5 mm	4	6 mm	75 mm	BLRM-040-4	30.05	BLRM-040-4X	34.95		

D1 +.0000" -.0030" (h6) decimal equiv.	L2	L3	D3	D2 (h6)	L1	Tool #	Price	Tool #	Price		
.1875 .1875	.375	2.00	.1675	2	.1875	3.0	BLR-187-2	35.45	BLR-187-2X	39.45	
.1875 .1875	.375	2.00	.1675	4	.1875	3.0	BLR-187-4	35.45	BLR-187-4X	39.45	
5 mm .1969	6.0 mm	11.0 mm	4.9 mm	2	6 mm	57 mm			SFBM-050-11X	40.35	
6 mm .2362	7.5 mm	12.5 mm	5.9 mm	2	6 mm	57 mm	SFBM-060-12	34.90	SFBM-060-12X	39.80	
6 mm .2362	7.5 mm	25.0 mm	5.9 mm	2	6 mm	57 mm	SFBM-060-25	37.60	SFBM-060-25X	42.50	
6 mm .2362	12.0 mm	50.0 mm	5.5 mm	2	6 mm	100 mm	BLRM-060-2	38.55			
6 mm .2362	12.0 mm	50.0 mm	5.5 mm	4	6 mm	100 mm	BLRM-060-4	38.55	BLRM-060-4X	43.45	
6 mm .2362	12.0 mm	50.0 mm	12.0 mm	3	6 mm	100 mm			BLRM-060-3X	43.45	
.2500 .2500	.500	2.50	.2300	2	.2500	4.0	BLR-250-2	42.75	BLR-250-2X	47.65	
.2500 .2500	.500	2.50	.2300	4	.2500	4.0	BLR-250-4	42.75	BLR-250-4X	47.65	
.3125 .3125	.625	2.63	.2925	2	.3125	4.0	BLR-312-2	49.25	BLR-312-2X	57.65	
8 mm .3150	14.0 mm	50.0 mm	7.5 mm	2	8 mm	100 mm	BLRM-080-2	52.60	BLRM-080-2X	58.40	
8 mm .3150	14.0 mm	50.0 mm	7.5 mm	4	8 mm	100 mm	BLRM-080-4	52.60	BLRM-080-4X	58.40	
.3750 .3750	.750	2.75	.3550	4	.3750	4.0	BLR-375-4	56.75	BLR-375-4X	65.15	
10 mm .3937	18.0 mm	65.0 mm	9.5 mm	2	10 mm	120 mm	BLRM-100-2	59.10			
10 mm .3937	18.0 mm	65.0 mm	9.5 mm	3	10 mm	120 mm	BLRM-100-3	59.10			
10 mm .3937	18.0 mm	65.0 mm	9.5 mm	4	10 mm	120 mm	BLRM-100-4	59.10	BLRM-100-4X	68.90	

\*.0005" / .013 mm max TIR. SFBM and MMBM tools held to h8 tolerance

Continued on next page

End Mills

## End Mills – Ball

### 2, 3, 4 Flute – Reduced Neck (cont.)

BLR / BLRM  
SFBM / MMBM

Continued from previous page

Cutter Diameter*		Length of Cut	Overall Reach	Neck Dia.	Flutes	Shank Dia.	Overall Length	Uncoated		AITIN Coated	
D1 +.0000" -.0030" (h6) decimal equiv.		L2	L3	D3	D2 (h6)	L1		Tool #	Price	Tool #	Price
		+ .015" -.000" +.38 mm -.00 mm	+ .030" -.030" +.38 mm -.38 mm								
.4375	.4375	1.000	4.50	.4175	2	.4375	6.0	BLR-437-2	85.60	BLR-437-2X	96.65
.4375	.4375	1.000	4.50	.4175	4	.4375	6.0	BLR-437-4	85.60		
12 mm	.4724	22.0 mm	80.0 mm	11.5 mm	2	12 mm	130 mm	BLRM-120-2	82.80	BLRM-120-2X	94.80
12 mm	.4724	22.0 mm	80.0 mm	11.5 mm	3	12 mm	130 mm	BLRM-120-3	82.80	BLRM-120-3X	94.80
12 mm	.4724	22.0 mm	80.0 mm	11.5 mm	4	12 mm	130 mm			BLRM-120-4X	94.80
.5000	.5000	1.000	4.50	.4800	2	.5000	6.0	BLR-500-2	97.90	BLR-500-2X	111.90
.5000	.5000	1.000	4.50	.4800	4	.5000	6.0	BLR-500-4	97.90	BLR-500-4X	111.90
.6250	.6250	1.250	4.50	.6050	2	.6250	6.0	BLR-625-2	173.45		
16 mm	.6299	30.0 mm	100.0 mm	15.5 mm	4	16 mm	150 mm	BLRM-160-4	146.20		
.7500	.7500	1.500	4.50	.7300	2	.7500	6.0	BLR-750-2	263.45		
20 mm	.7874	38.0 mm	100.0 mm	19.5 mm	3	20 mm	150 mm	BLRM-200-3	239.20	BLRM-200-3X	264.30
20 mm	.7874	38.0 mm	100.0 mm	19.5 mm	4	20 mm	150 mm	BLRM-200-4	239.20	BLRM-200-4X	264.30
20 mm	.7874	38.0 mm	100.0 mm	38.0 mm	2	20 mm	150 mm			BLRM-200-2X	264.30
1.0000	1.0000	1.500	4.50	.9800	4	1.000	6.0	BLR-001-4	399.35		

\*.0005" / .013 mm max TIR. SFBM and MMBM tools held to h8 tolerance

AECM / GEC

End Mills – Corner Radius  
2, 3, 4 Flute

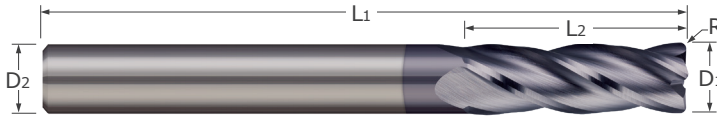

- Designed for general purpose machining
- 30° helix ■ Center cutting
- Corner radius profile
- AlTiN coating option for added lubricity and increased wear resistance in difficult-to-machine materials
- Solid carbide
- CNC ground in the USA

Cutter Diameter*			Length of Cut	Corner Radius	Flutes	Shank Diameter	Overall Length	Uncoated		AlTiN Coated	
D1			L2	R		D2 (h6)	L1	Tool #	Price	Tool #	Price
+ .0000" - .0020"	(h9)	decimal equiv.	+ .031" - .000" + .79 mm - .00 mm	+ .0000" - .0005" + .000 mm - .013 mm							
.0312		.0312	.078	.005	2	.1250	1.5	GEC-031-2-005	17.20	GEC-031-2-005X	19.70
.0312		.0312	.078	.005	3	.1250	1.5	GEC-031-3-005	17.20	GEC-031-3-005X	19.70
.0312		.0312	.078	.005	4	.1250	1.5			GEC-031-4-005X	19.70
1 mm		.0394	4 mm	0.1 mm	4	4 mm	50 mm			AECM-0101-4X	21.95
1 mm		.0394	4 mm	0.2 mm	4	4 mm	50 mm			AECM-0102-4X	21.95
.0625		.0625	.188	.005	2	.1250	1.5	GEC-062-2-005	15.50		
.0625		.0625	.188	.005	3	.1250	1.5	GEC-062-3-005	15.50	GEC-062-3-005X	18.00
.0625		.0625	.188	.005	4	.1250	1.5	GEC-062-4-005	15.50	GEC-062-4-005X	18.00
.0625		.0625	.188	.010	3	.1250	1.5	GEC-062-3-010	15.50	GEC-062-3-010X	18.00
.0625		.0625	.188	.010	4	.1250	1.5	GEC-062-4-010	15.50	GEC-062-4-010X	18.00
2 mm		.0787	5 mm	0.2 mm	4	4 mm	50 mm			AECM-0202-4X	21.95
2 mm		.0787	5 mm	0.5 mm	4	4 mm	50 mm			AECM-0205-4X	21.95
.0938		.0938	.375	.005	4	.1250	1.5			GEC-093-4-005X	18.00
.0938		.0938	.375	.010	2	.1250	1.5	GEC-093-2-010	15.50	GEC-093-2-010X	18.00
.0938		.0938	.375	.010	3	.1250	1.5	GEC-093-3-010	15.50	GEC-093-3-010X	18.00
.0938		.0938	.375	.010	4	.1250	1.5			GEC-093-4-010X	18.00
3 mm		.1181	8 mm	0.5 mm	4	6 mm	57 mm			AECM-0305-4X	28.85
.1250		.1250	.500	.010	3	.1250	1.5	GEC-125-3-010	15.50	GEC-125-3-010X	18.00
.1250		.1250	.500	.010	4	.1250	1.5	GEC-125-4-010	15.50	GEC-125-4-010X	18.00
.1250		.1250	.500	.020	2	.1250	1.5			GEC-125-2-020X	18.00
.1250		.1250	.500	.020	3	.1250	1.5	GEC-125-3-020	15.50	GEC-125-3-020X	18.00
.1250		.1250	.500	.020	4	.1250	1.5	GEC-125-4-020	15.50	GEC-125-4-020X	18.00
4 mm		.1575	11 mm	0.2 mm	4	6 mm	57 mm			AECM-0402-4X	28.85
4 mm		.1575	11 mm	0.5 mm	4	6 mm	57 mm			AECM-0405-4X	28.85
.1875		.1875	.625	.010	4	.1875	2.0	GEC-187-4-010	22.05	GEC-187-4-010X	24.95
.1875		.1875	.625	.020	3	.1875	2.0	GEC-187-3-020	22.05	GEC-187-3-020X	24.95
.1875		.1875	.625	.030	2	.1875	2.0	GEC-187-2-030	22.05		
.1875		.1875	.625	.030	3	.1875	2.0	GEC-187-3-030	22.05	GEC-187-3-030X	24.95
.1875		.1875	.625	.030	4	.1875	2.0			GEC-187-4-030X	24.95
5 mm		.1969	16 mm	1.0 mm	3	6 mm	57 mm	AECM-0510-3	23.95		
6 mm		.2362	16 mm	0.3 mm	4	6 mm	57 mm	AECM-0603-4	23.95	AECM-0603-4X	28.85
6 mm		.2362	16 mm	0.5 mm	4	6 mm	57 mm	AECM-0605-4	23.95	AECM-0605-4X	28.85
6 mm		.2362	16 mm	1.0 mm	4	6 mm	57 mm			AECM-0610-4X	28.85

\*.0005" / .013 mm max TIR

Continued on next page

# End Mills – Corner Radius

AECM / GEC

## 2, 3, 4 Flute (cont.)

Continued from previous page

End Mills

Cutter Diameter*		Length of Cut	Corner Radius	Flutes	Shank Diameter	Overall Length	Uncoated		AITIN Coated	
D1 +.0000" -.0020" (h9) decimal equiv.	L2	R	D2 (h6)	L1	Tool #	Price	Tool #	Price	Tool #	Price
	+.031" -.000" +.79 mm -.00 mm	+.0000" -.0005" +.000 mm -.013 mm								
.2500	.2500	.750	.010	2	.2500	2.5	GEC-250-2-010	27.65	GEC-250-2-010X	32.55
.2500	.2500	.750	.010	4	.2500	2.5	GEC-250-4-010	27.65	GEC-250-4-010X	32.55
.2500	.2500	.750	.020	2	.2500	2.5	GEC-250-2-020	27.65		
.2500	.2500	.750	.020	3	.2500	2.5			GEC-250-3-020X	32.55
.2500	.2500	.750	.020	4	.2500	2.5			GEC-250-4-020X	32.55
.2500	.2500	.750	.030	3	.2500	2.5	GEC-250-3-030	27.65	GEC-250-3-030X	32.55
.2500	.2500	.750	.030	4	.2500	2.5	GEC-250-4-030	27.65	GEC-250-4-030X	32.55
	+.031" -.000" +.79 mm -.00 mm	+.0000" -.0005" +.000 mm -.013 mm								
.3125	.3125	.813	.010	2	.3125	2.5	GEC-312-2-010	32.20	GEC-312-2-010X	39.00
.3125	.3125	.813	.010	4	.3125	2.5	GEC-312-4-010	32.20	GEC-312-4-010X	39.00
.3125	.3125	.813	.020	2	.3125	2.5	GEC-312-2-020	32.20		
8 mm	.3150	22 mm	1.0 mm	2	8 mm	63 mm	AECM-0810-2	29.55		
8 mm	.3150	22 mm	1.5 mm	3	8 mm	63 mm			AECM-0815-3X	36.35
.3750	.3750	.875	.010	2	.3750	2.5	GEC-375-2-010	36.55	GEC-375-2-010X	43.35
.3750	.3750	.875	.010	4	.3750	2.5	GEC-375-4-010	36.55	GEC-375-4-010X	43.35
.3750	.3750	.875	.020	4	.3750	2.5	GEC-375-4-020	36.55		
.3750	.3750	.875	.030	3	.3750	2.5	GEC-375-3-030	36.55	GEC-375-3-030X	43.35
.3750	.3750	.875	.030	4	.3750	2.5			GEC-375-4-030X	43.35
10 mm	.3937	25 mm	0.5 mm	2	10 mm	72 mm	AECM-1005-2	34.85		
10 mm	.3937	25 mm	0.5 mm	4	10 mm	72 mm	AECM-1005-4	34.85	AECM-1005-4X	41.65
10 mm	.3937	25 mm	1.0 mm	4	10 mm	72 mm			AECM-1010-4X	41.65
10 mm	.3937	25 mm	1.5 mm	3	10 mm	72 mm	AECM-1015-3	34.85	AECM-1015-3X	41.65
10 mm	.3937	25 mm	1.5 mm	4	10 mm	72 mm	AECM-1015-4	34.85		
12 mm	.4724	30 mm	0.5 mm	4	12 mm	83 mm	AECM-1205-4	55.65		
12 mm	.4724	30 mm	1.0 mm	4	12 mm	83 mm			AECM-1210-4X	65.95
12 mm	.4724	30 mm	1.5 mm	2	12 mm	83 mm			AECM-1215-2X	65.95
12 mm	.4724	30 mm	1.5 mm	3	12 mm	83 mm			AECM-1215-3X	65.95
12 mm	.4724	30 mm	1.5 mm	4	12 mm	83 mm	AECM-1215-4	55.65	AECM-1215-4X	65.95
.5000	.5000	1.000	.010	4	.5000	3.0	GEC-500-4-010	63.25	GEC-500-4-010X	71.45
.5000	.5000	1.000	.030	3	.5000	3.0	GEC-500-3-030	63.25	GEC-500-3-030X	71.45
.6250	.6250	1.250	.020	2	.6250	3.5	GEC-625-2-020	111.85		
.6250	.6250	1.250	.030	3	.6250	3.5	GEC-625-3-030	111.85		
.6250	.6250	1.250	.060	2	.6250	3.5	GEC-625-2-060	111.85		
.6250	.6250	1.250	.090	2	.6250	3.5	GEC-625-2-090	111.85		
.6250	.6250	1.250	.090	3	.6250	3.5	GEC-625-3-090	111.85		
.6250	.6250	1.250	.090	4	.6250	3.5	GEC-625-4-090	111.85		
.7500	.7500	1.500	.020	2	.7500	4.0	GEC-750-2-020	170.65		
.7500	.7500	1.500	.060	2	.7500	4.0	GEC-750-2-060	170.65		
1.0000	1.0000	1.500	.020	2	1.0000	4.0	GEC-001-2-020	258.45		
1.0000	1.0000	1.500	.030	2	1.0000	4.0	GEC-001-2-030	258.45		
1.0000	1.0000	1.500	.060	2	1.0000	4.0	GEC-001-2-060	258.45		
1.0000	1.0000	1.500	.090	2	1.0000	4.0	GEC-001-2-090	258.45		
1.0000	1.0000	1.500	.125	2	1.0000	4.0	GEC-001-2-125	258.45		

\*.0005" / .013 mm max TIR

## MMRM

## End Mills – Corner Radius

### 2 Flute – Reduced Neck

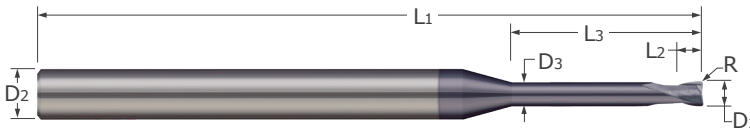

- Designed for mold making applications
- Manufactured to tighter cutter diameter tolerance (h8) for mold making applications
- Long reach for deep pocket milling
- Reduced neck diameter to avoid heeling
- Corner radius profile
- 30° helix ■ Center cutting
- AlTiN coating option for added lubricity and increased wear resistance in difficult-to-machine materials
- Solid carbide ■ CNC ground in the USA

Cutter Diameter*	Length of Cut	Corner Radius	Overall Reach	Neck Diameter	Shank Diameter	Overall Length	Uncoated		AlTiN Coated	
							Tool #	Price	Tool #	Price
D1 (h8)	L2 $^{+.38mm}_{-.00mm}$	R $^{+.000mm}_{-.013mm}$	L3 $^{+.25mm}_{-.00mm}$	D3 $^{+.00mm}_{-.13mm}$	D2 (h6)	L1				
0.5 mm	0.5 mm	0.05 mm	10 mm	0.48 mm	4 mm	50 mm	MMRM-005-10	32.30		
0.8 mm	0.8 mm	0.1 mm	5 mm	0.78 mm	4 mm	50 mm	MMRM-008-5	27.50	MMRM-008-5X	30.40
0.8 mm	0.8 mm	0.1 mm	10 mm	0.78 mm	4 mm	50 mm	MMRM-008-10	27.50	MMRM-008-10X	30.40
0.8 mm	0.8 mm	0.1 mm	16 mm	0.78 mm	4 mm	50 mm	MMRM-008-16	27.50	MMRM-008-16X	30.40
1 mm	1 mm	0.1 mm	5 mm	0.95 mm	6 mm	57 mm	MMRM-010-5	30.40		
1 mm	1 mm	0.1 mm	8 mm	0.95 mm	6 mm	57 mm	MMRM-010-8	30.40		
1 mm	1 mm	0.1 mm	10 mm	0.95 mm	6 mm	57 mm	MMRM-010-10	30.40	MMRM-010-10X	35.30
1 mm	1 mm	0.1 mm	20 mm	0.95 mm	6 mm	57 mm	MMRM-010-20	30.40	MMRM-010-20X	35.30
1.2 mm	1.2 mm	0.1 mm	15 mm	1.15 mm	6 mm	57 mm			MMRM-012-15X	35.30
1.5 mm	1.5 mm	0.15 mm	7 mm	1.45 mm	6 mm	57 mm	MMRM-015-7	30.40	MMRM-015-7X	35.30
1.5 mm	1.5 mm	0.15 mm	15 mm	1.45 mm	6 mm	57 mm	MMRM-015-15	30.40	MMRM-015-15X	35.30
1.5 mm	1.5 mm	0.15 mm	25 mm	1.45 mm	6 mm	72 mm	MMRM-015-25	30.40	MMRM-015-25X	35.30
2 mm	2 mm	0.2 mm	7 mm	1.9 mm	6 mm	57 mm	MMRM-020-7	30.40		
2 mm	2 mm	0.2 mm	30 mm	1.9 mm	6 mm	72 mm	MMRM-020-30	30.40		
3 mm	3 mm	0.25 mm	8 mm	2.9 mm	6 mm	57 mm	MMRM-030-8	30.40	MMRM-030-8X	35.30
3 mm	3 mm	0.25 mm	15 mm	2.9 mm	6 mm	57 mm	MMRM-030-15	30.40		
3 mm	3 mm	0.25 mm	30 mm	2.9 mm	6 mm	72 mm	MMRM-030-30	30.40	MMRM-030-30X	35.30
4 mm	4 mm	0.25 mm	9 mm	3.8 mm	6 mm	57 mm	MMRM-040-9	30.40	MMRM-040-9X	35.30
4 mm	4 mm	0.25 mm	15 mm	3.8 mm	6 mm	57 mm	MMRM-040-15	30.40	MMRM-040-15X	35.30
4 mm	4 mm	0.25 mm	30 mm	3.8 mm	6 mm	72 mm			MMRM-040-30X	35.30
5 mm	5 mm	0.05 mm	30 mm	4.8 mm	6 mm	72 mm	MMRM-050-30	30.40	MMRM-050-30X	35.30
6 mm	6 mm	1 mm	11 mm	5.8 mm	6 mm	57 mm	MMRM-060-11	30.40	MMRM-060-11X	35.30
10 mm	10 mm	1 mm	25 mm	9.8 mm	10 mm	72 mm	MMRM-100-25	46.25		
12 mm	12 mm	1.5 mm	25 mm	11.8 mm	12 mm	83 mm	MMRM-120-25	73.95		

\*.0005" / .013 mm max TIR

# End Mills For Hardened Steels

HMCM

## Corner Radius – 4 Flute

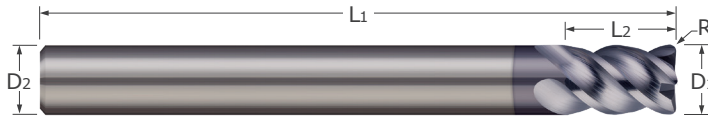

Hardened Steels

- Designed for high performance in hardened tool, die, stainless, and mold steels
- Optimized geometry for increased edge strength in hard milling applications
- Corner radius profile for added edge strength
- 45° helix ■ Center cutting
- AlTiN coating option for added lubricity and increased wear resistance in difficult-to-machine materials
- Solid carbide ■ CNC ground in the USA

Cutter Diameter*	Length of Cut	Corner Radius	Shank Diameter	Overall Length	Uncoated		AlTiN Coated	
					Tool #	Price	Tool #	Price
D1 (h8)	L2 <sup>+0.38 mm</sup> / <sub>-0.00 mm</sub>	R <sup>+0.000 mm</sup> / <sub>-0.013 mm</sub>	D2 (h6)	L1				
3 mm	8 mm	0.5 mm	6 mm	57 mm			HMCM-0305-4X	69.15
4 mm	11 mm	0.2 mm	6 mm	57 mm	HMCM-0402-4	64.25		
4 mm	11 mm	0.5 mm	6 mm	57 mm	HMCM-0405-4	64.25	HMCM-0405-4X	69.15
4 mm	11 mm	1.0 mm	6 mm	57 mm			HMCM-0410-4X	69.15
5 mm	13 mm	1.0 mm	6 mm	57 mm			HMCM-0510-4X	74.30
6 mm	13 mm	0.5 mm	6 mm	57 mm	HMCM-0605-4	69.40		
6 mm	13 mm	1.0 mm	6 mm	57 mm			HMCM-0610-4X	74.30
8 mm	19 mm	0.5 mm	8 mm	75 mm			HMCM-0805-4X	81.45
8 mm	19 mm	1.0 mm	8 mm	75 mm	HMCM-0810-4	74.65		
8 mm	19 mm	1.5 mm	8 mm	75 mm			HMCM-0815-4X	81.45
8 mm	19 mm	2.0 mm	8 mm	75 mm	HMCM-0820-4	74.65		
10 mm	22 mm	0.5 mm	10 mm	80 mm	HMCM-1005-4	82.30	HMCM-1005-4X	89.10
10 mm	22 mm	2.0 mm	10 mm	80 mm	HMCM-1020-4	82.30		
12 mm	26 mm	0.5 mm	12 mm	100 mm			HMCM-1205-4X	114.50
12 mm	26 mm	1.0 mm	12 mm	100 mm			HMCM-1210-4X	114.50
12 mm	26 mm	1.5 mm	12 mm	100 mm			HMCM-1215-4X	114.50
12 mm	26 mm	2.0 mm	12 mm	100 mm			HMCM-1220-4X	114.50
16 mm	32 mm	1.0 mm	16 mm	110 mm			HMCM-1610-4X	238.60
16 mm	32 mm	2.0 mm	16 mm	110 mm			HMCM-1620-4X	238.60
20 mm	38 mm	1.0 mm	20 mm	125 mm			HMCM-2010-4X	327.55
20 mm	38 mm	1.5 mm	20 mm	125 mm			HMCM-2015-4X	327.55
20 mm	38 mm	1.5 mm	20 mm	125 mm	HMCM-2015-4	304.75		
20 mm	38 mm	2.0 mm	20 mm	125 mm	HMCM-2020-4	304.75	HMCM-2020-4X	327.55
20 mm	38 mm	3.0 mm	20 mm	125 mm	HMCM-2030-4	304.75	HMCM-2030-4X	327.55

\*.0005" / .013 mm max TIR

MEF / MEFM

End Mills For Steels & High Temperature Alloys  
Square – 2 & 3 Flute – Stub Flute

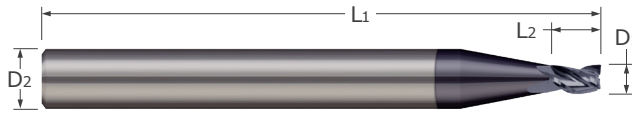

- Designed for high performance in titanium alloys, inconel, nickel alloys, and other high-temperature materials with outstanding performance in difficult-to-machine steels, stainless steels, and tool steels
- Stub flutes for maximum rigidity
- Square profile ■ 20° helix ■ Center cutting
- nACRo® coating option for added heat resistance in difficult-to-machine materials
- Solid carbide ■ CNC ground in the USA

Cutter Diameter*			Length of Cut L2	Flutes	Shank Diameter D2 (h6)	Overall Length L1	Uncoated		nACRo® Coated	
D1 +.0000" -.0005"	+.000 mm -.013 mm	decimal equiv.					Tool #	Price	Tool #	Price
	0.1 mm	.0039	+.015" -.000" +.38 mm -.00 mm	2	3 mm	38 mm			MEFM-001-015K	67.10
	0.15 mm	.0059		2	3 mm	38 mm	MEFM-0015-025	51.00	MEFM-0015-025K	55.10
	0.2 mm	.0079		2	3 mm	38 mm	MEFM-002-030	42.50	MEFM-002-030K	46.60
.0100	.0100	.0100	.015	2	.1250	1.5	MEF-010-015	37.75	MEF-010-015K	41.85
.0100	.0100	.0100	.015	3	.1250	1.5	MEF-010-015-3	37.75	MEF-010-015-3K	41.85
	0.3 mm	.0118	0.45 mm	2	3 mm	38 mm	MEFM-003-045	37.75	MEFM-003-045K	41.85
.0150	.0150	.0150	.023	2	.1250	1.5	MEF-015-023	33.50	MEF-015-023K	37.60
.0150	.0150	.0150	.023	3	.1250	1.5	MEF-015-023-3	33.50	MEF-015-023-3K	37.60
	0.4 mm	.0157	0.6 mm	2	3 mm	38 mm	MEFM-004-060	33.50	MEFM-004-060K	37.60
.0200	.0200	.0200	.030	2	.1250	1.5			MEF-020-030K	27.60
.0200	.0200	.0200	.030	3	.1250	1.5	MEF-020-030-3	23.50	MEF-020-030-3K	27.60
	0.6 mm	.0236	0.9 mm	2	3 mm	38 mm	MEFM-006-090	23.50	MEFM-006-090K	27.60
.0250	.0250	.0250	.038	2	.1250	1.5	MEF-025-038	23.50	MEF-025-038K	27.60
.0250	.0250	.0250	.038	3	.1250	1.5	MEF-025-038-3	23.50	MEF-025-038-3K	27.60
.0300	.0300	.0300	.045	2	.1250	1.5	MEF-030-045	21.50	MEF-030-045K	25.60
.0300	.0300	.0300	.045	3	.1250	1.5	MEF-030-045-3	21.50	MEF-030-045-3K	25.60
.0313	.0313	.0313	.047	2	.1250	1.5	MEF-031-047	21.50	MEF-031-047K	25.60
.0313	.0313	.0313	.047	3	.1250	1.5			MEF-031-047-3K	25.60
	0.8 mm	.0315	1.2 mm	2	3 mm	38 mm	MEFM-008-120	21.50	MEFM-008-120K	25.60
.0350	.0350	.0350	.053	2	.1250	1.5	MEF-035-053	21.50	MEF-035-053K	25.60
.0350	.0350	.0350	.053	3	.1250	1.5	MEF-035-053-3	21.50	MEF-035-053-3K	25.60
	1 mm	.0394	1.5 mm	2	3 mm	38 mm	MEFM-010-150	21.50	MEFM-010-150K	25.60
.0400	.0400	.0400	.060	2	.1250	1.5	MEF-040-060	21.50	MEF-040-060K	25.60
.0400	.0400	.0400	.060	3	.1250	1.5	MEF-040-060-3	21.50	MEF-040-060-3K	25.60
.0450	.0450	.0450	.068	2	.1250	1.5	MEF-045-068	21.50	MEF-045-068K	25.60
.0450	.0450	.0450	.068	3	.1250	1.5	MEF-045-068-3	21.50	MEF-045-068-3K	25.60
.0469	.0469	.0469	.071	2	.1250	1.5	MEF-047-071	21.50	MEF-047-071K	25.60
.0469	.0469	.0469	.071	3	.1250	1.5	MEF-047-071-3	21.50	MEF-047-071-3K	25.60
	1.2 mm	.0472	1.8 mm	2	3 mm	38 mm	MEFM-012-180	21.50	MEFM-012-180K	25.60
.0500	.0500	.0500	.075	2	.1250	1.5	MEF-050-075	21.50		
.0500	.0500	.0500	.075	3	.1250	1.5	MEF-050-075-3	21.50	MEF-050-075-3K	25.60

\*.0005" / .013 mm max TIR

Continued on next page

# End Mills For Steels & High Temperature Alloys

MEF / MEFM

Square – 2 & 3 Flute – Stub Flute (cont.)

Continued from previous page

Steels & High Temp. Alloys

Cutter Diameter*			Length of Cut	Flutes	Shank Diameter	Overall Length	Uncoated		nACRo® Coated	
D1 +.0000" -.0005"	+.000 mm -.013 mm	decimal equiv.	L2 +.015" -.000" +.38 mm -.00 mm	D2 (h6)	L1	Tool #	Price	Tool #	Price	
										.0600
.0600	.0600	.0600	.090	3	.1250	1.5	MEF-060-090-3	21.50	MEF-060-090-3K	25.60
.0625	.0625	.0625	.093	2	.1250	1.5	MEF-062-093	21.50		
.0625	.0625	.0625	.093	3	.1250	1.5	MEF-062-093-3	21.50		
.0750	.0750	.0750	.113	2	.1250	1.5	MEF-075-113	21.50	MEF-075-113K	25.60
.0750	.0750	.0750	.113	3	.1250	1.5	MEF-075-113-3	21.50	MEF-075-113-3K	25.60
.0781	.0781	.0781	.117	2	.1250	1.5			MEF-078-117K	25.60
.0781	.0781	.0781	.117	3	.1250	1.5			MEF-078-117-3K	25.60
2 mm	.0787	.0787	2.5 mm	2	3 mm	38 mm	MEFM-020-250	21.50	MEFM-020-250K	25.60
.0900	.0900	.0900	.125	2	.1250	1.5	MEF-090-125	21.50	MEF-090-125K	25.60
.0938	.0938	.0938	.125	2	.1250	1.5			MEF-093-125K	25.60
2.5 mm	.0984	.0984	3 mm	2	3 mm	38 mm	MEFM-025-300	21.50	MEFM-025-300K	25.60
3 mm	.1181	.1181	3 mm	2	6 mm	57 mm	MEFM-030-300	28.50	MEFM-030-300K	35.70
.1250	.1250	.1250	.125	2	.1875	2.0	MEF-125-125	23.50	MEF-125-125K	28.10
4 mm	.1575	.1575	5 mm	2	6 mm	57 mm	MEFM-040-500	28.50	MEFM-040-500K	35.70
.1875	.1875	.1875	.200	2	.2500	2.5	MEF-187-250	28.50	MEF-187-250K	35.70

D1 +.0000" -.0010"	decimal equiv.	L2 +.015" -.000"	D2 (h6)	L1	Tool #	Price	Tool #	Price	
.2500	.2500	.250	2	.2500	2.5	MEF-250-250	28.50	MEF-250-250K	35.70

\*.0005" / .013 mm max TIR



MEF / MEFM

End Mills For Steels & High Temperature Alloys

Square – 2 & 3 Flute – Long Reach, Stub Flute

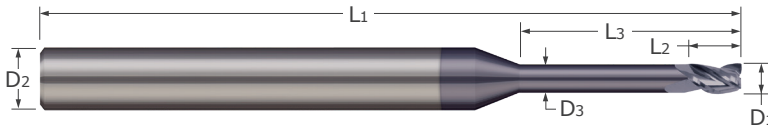

- Designed for high performance in titanium alloys, inconel, nickel alloys, and other high-temperature materials with outstanding performance in difficult-to-machine steels, stainless steels, and tool steels
- Long reach for deep pocket milling
- Stub flutes for maximum rigidity
- Reduced neck diameter to avoid heeling
- Square profile ■ 20° helix ■ Center cutting
- nACRo® coating option for added heat resistance in difficult to machine materials
- Solid carbide ■ CNC ground in the USA

Cutter Diameter*			Length of Cut	Overall Reach	Neck Dia.	Flutes	Shank Dia.	Overall Length	Uncoated		nACRo® Coated	
D1 +.0000" +.000 mm -.0005" -.013 mm	decimal equiv.	L2	L3	D3	D2 (h6)	L1	Tool #	Price	Tool #	Price		
											+.015" +.010" -.000" -.010"	+.38 mm +.25 mm -.00 mm -.00 mm
.0100	.0100	.015	.050	.009	2	.1250	1.5	MEF-010-050	42.75	MEF-010-050K	46.85	
.0100	.0100	.015	.050	.009	3	.1250	1.5	MEF-010-050-3	42.75	MEF-010-050-3K	46.85	
.0100	.0100	.015	.075	.009	2	.1250	1.5	MEF-010-075	42.75	MEF-010-075K	46.85	
.0100	.0100	.015	.075	.009	3	.1250	1.5	MEF-010-075-3	42.75	MEF-010-075-3K	46.85	
.0150	.0150	.023	.100	.014	2	.1250	1.5	MEF-015-100	38.50	MEF-015-100K	42.60	
.0150	.0150	.023	.100	.014	3	.1250	1.5	MEF-015-100-3	38.50	MEF-015-100-3K	42.60	
.0150	.0150	.023	.200	.014	2	.1250	1.5	MEF-015-200	39.50	MEF-015-200K	43.60	
.0150	.0150	.023	.200	.014	3	.1250	1.5	MEF-015-200-3	39.50	MEF-015-200-3K	43.60	
.0200	.0200	.030	.150	.019	2	.1250	1.5	MEF-020-150	28.50	MEF-020-150K	32.60	
.0200	.0200	.030	.150	.019	3	.1250	1.5	MEF-020-150-3	28.50	MEF-020-150-3K	32.60	
.0200	.0200	.030	.250	.019	2	.1250	1.5	MEF-020-250	29.50	MEF-020-250K	33.60	
.0200	.0200	.030	.250	.019	3	.1250	1.5	MEF-020-250-3	29.50	MEF-020-250-3K	33.60	
0.6 mm	.0236	0.9 mm	3 mm	0.55 mm	2	3 mm	38 mm	MEFM-006-300	28.50	MEFM-006-300K	32.60	
0.6 mm	.0236	0.9 mm	5 mm	0.55 mm	2	3 mm	38 mm	MEFM-006-500	29.50	MEFM-006-500K	33.60	
0.6 mm	.0236	0.9 mm	6 mm	0.55 mm	2	3 mm	38 mm	MEFM-006-600	31.00	MEFM-006-600K	35.10	
.0250	.0250	.038	.250	.024	3	.1250	1.5	MEF-025-250-3	29.50	MEF-025-250-3K	33.60	
.0250	.0250	.038	.150	.024	3	.1250	1.5	MEF-025-150-3	28.50			
.0250	.0250	.038	.250	.024	2	.1250	1.5	MEF-025-250	29.50	MEF-025-250K	33.60	
.0250	.0250	.038	.150	.024	2	.1250	1.5			MEF-025-150K	32.60	
.0300	.0300	.045	.100	.028	2	.1250	1.5	MEF-030-100	26.50	MEF-030-100K	30.60	
.0300	.0300	.045	.100	.028	3	.1250	1.5	MEF-030-100-3	26.50	MEF-030-100-3K	30.60	
.0300	.0300	.045	.200	.028	2	.1250	1.5	MEF-030-200	27.50			
.0300	.0300	.045	.200	.028	3	.1250	1.5	MEF-030-200-3	27.50	MEF-030-200-3K	31.60	
.0300	.0300	.045	.375	.028	2	.1250	1.5	MEF-030-375	30.50	MEF-030-375K	34.60	
.0300	.0300	.045	.375	.028	3	.1250	1.5	MEF-030-375-3	30.50	MEF-030-375-3K	34.60	
.0313	.0313	.047	.100	.029	2	.1250	1.5	MEF-031-100	26.50	MEF-031-100K	30.60	
.0313	.0313	.047	.100	.029	3	.1250	1.5	MEF-031-100-3	26.50	MEF-031-100-3K	30.60	
.0313	.0313	.047	.200	.029	2	.1250	1.5	MEF-031-200	27.50	MEF-031-200K	31.60	
.0313	.0313	.047	.200	.029	3	.1250	1.5	MEF-031-200-3	27.50	MEF-031-200-3K	31.60	
.0313	.0313	.047	.375	.029	2	.1250	1.5	MEF-031-375	30.50	MEF-031-375K	34.60	
.0313	.0313	.047	.375	.029	3	.1250	1.5	MEF-031-375-3	30.50	MEF-031-375-3K	34.60	

\*.0005" / .013 mm max TIR

Continued on next page

# End Mills For Steels & High Temperature Alloys

## Square – 2 & 3 Flute – Long Reach, Stub Flute (cont.)

MEF / MEFM

Continued from previous page

Cutter Diameter*			Length of Cut	Overall Reach	Neck Dia.	Flutes	Shank Dia.	Overall Length	Uncoated		nACRo® Coated	
D1 +.0000" -.0005"	+.000 mm -.013 mm	decimal equiv.	L2 +.015" -.000" +.38 mm -.00 mm	L3 +.010" -.010" +.25 mm -.00 mm	D3	D2 (h6)	L1	Tool #	Price	Tool #	Price	
												Tool #
0.8 mm	.0315		1.2 mm	4 mm	0.75 mm	2	3 mm	38 mm	MEFM-008-400	28.50	MEFM-008-400K	32.60
0.8 mm	.0315		1.2 mm	7 mm	0.75 mm	2	3 mm	38 mm	MEFM-008-700	31.00	MEFM-008-700K	35.10
0.8 mm	.0315		1.2 mm	9 mm	0.75 mm	2	3 mm	38 mm	MEFM-008-900	35.00	MEFM-008-900K	39.10
.0350	.0350		.053	.150	.033	2	.1250	1.5	MEF-035-150	26.50	MEF-035-150K	30.60
.0350	.0350		.053	.150	.033	3	.1250	1.5	MEF-035-150-3	26.50	MEF-035-150-3K	30.60
.0350	.0350		.053	.250	.033	2	.1250	1.5	MEF-035-250	27.50	MEF-035-250K	31.60
.0350	.0350		.053	.250	.033	3	.1250	1.5	MEF-035-250-3	27.50	MEF-035-250-3K	31.60
.0350	.0350		.053	.400	.033	2	.1250	1.5	MEF-035-400	30.50		
.0350	.0350		.053	.400	.033	3	.1250	1.5	MEF-035-400-3	30.50	MEF-035-400-3K	34.60
1 mm	.0394		1.5 mm	4 mm	0.95 mm	2	3 mm	38 mm	MEFM-010-400	28.50	MEFM-010-400K	32.60
1 mm	.0394		1.5 mm	7 mm	0.95 mm	2	3 mm	38 mm	MEFM-010-700	31.00	MEFM-010-700K	35.10
1 mm	.0394		1.5 mm	9 mm	0.95 mm	2	3 mm	38 mm	MEFM-010-900	35.00	MEFM-010-900K	39.10
.0400	.0400		.060	.150	.038	2	.1250	1.5			MEF-040-150K	30.60
.0400	.0400		.060	.150	.038	3	.1250	1.5			MEF-040-150-3K	30.60
.0400	.0400		.060	.250	.038	2	.1250	1.5	MEF-040-250	27.50	MEF-040-250K	31.60
.0400	.0400		.060	.250	.038	3	.1250	1.5	MEF-040-250-3	27.50	MEF-040-250-3K	31.60
.0400	.0400		.060	.500	.038	2	.1250	1.5	MEF-040-500	32.50	MEF-040-500K	36.60
.0400	.0400		.060	.500	.038	3	.1250	1.5	MEF-040-500-3	32.50	MEF-040-500-3K	36.60
.0450	.0450		.068	.150	.043	2	.1250	1.5	MEF-045-150	26.50	MEF-045-150K	30.60
.0450	.0450		.068	.150	.043	3	.1250	1.5	MEF-045-150-3	26.50	MEF-045-150-3K	30.60
.0450	.0450		.068	.250	.043	2	.1250	1.5	MEF-045-250	27.50	MEF-045-250K	31.60
.0450	.0450		.068	.250	.043	3	.1250	1.5	MEF-045-250-3	27.50	MEF-045-250-3K	31.60
.0450	.0450		.068	.500	.043	2	.1250	1.5			MEF-045-500K	36.60
.0450	.0450		.068	.500	.043	3	.1250	1.5	MEF-045-500-3	32.50	MEF-045-500-3K	36.60
.0469	.0469		.071	.150	.045	2	.1250	1.5	MEF-047-150	26.50	MEF-047-150K	30.60
.0469	.0469		.071	.150	.045	3	.1250	1.5	MEF-047-150-3	26.50	MEF-047-150-3K	30.60
.0469	.0469		.071	.250	.045	2	.1250	1.5			MEF-047-250K	31.60
.0469	.0469		.071	.250	.045	3	.1250	1.5	MEF-047-250-3	27.50	MEF-047-250-3K	31.60
.0469	.0469		.071	.500	.045	2	.1250	1.5	MEF-047-500	32.50	MEF-047-500K	36.60
.0469	.0469		.071	.500	.045	3	.1250	1.5	MEF-047-500-3	32.50	MEF-047-500-3K	36.60
1.2 mm	.0472		1.8 mm	6 mm	1.1 mm	2	3 mm	38 mm	MEFM-012-600	31.00	MEFM-012-600K	35.10
1.2 mm	.0472		1.8 mm	10 mm	1.1 mm	2	3 mm	38 mm	MEFM-012-1000	35.00	MEFM-012-1000K	39.10
1.2 mm	.0472		1.8 mm	12 mm	1.1 mm	2	3 mm	38 mm	MEFM-012-1200	37.75	MEFM-012-1200K	41.85
.0500	.0500		.075	.200	.048	2	.1250	1.5	MEF-050-200	26.50	MEF-050-200K	30.60
.0500	.0500		.075	.200	.048	3	.1250	1.5	MEF-050-200-3	26.50	MEF-050-200-3K	30.60
.0500	.0500		.075	.300	.048	2	.1250	1.5	MEF-050-300	28.50	MEF-050-300K	32.60
.0500	.0500		.075	.300	.048	3	.1250	1.5	MEF-050-300-3	28.50	MEF-050-300-3K	32.60
.0500	.0500		.075	.550	.048	2	.1250	1.5	MEF-050-550	32.50	MEF-050-550K	36.60
.0500	.0500		.075	.550	.048	3	.1250	1.5	MEF-050-550-3	32.50	MEF-050-550-3K	36.60
1.5 mm	.0591		2.2 mm	6 mm	1.4 mm	2	3 mm	38 mm	MEFM-015-600	31.00	MEFM-015-600K	35.10
1.5 mm	.0591		2.2 mm	10 mm	1.4 mm	2	3 mm	38 mm	MEFM-015-1000	35.00	MEFM-015-1000K	39.10
1.5 mm	.0591		2.2 mm	12 mm	1.4 mm	2	3 mm	38 mm	MEFM-015-1200	37.75	MEFM-015-1200K	41.85

\*.0005" / .013 mm max TIR

Continued on next page

Steels & High Temp. Alloys

MEF / MEFM

End Mills For Steels & High Temperature Alloys  
Square – 2 & 3 Flute – Long Reach, Stub Flute (cont.)

Continued from previous page

Cutter Diameter*			Length of Cut	Overall Reach	Neck Dia.	Flutes	Shank Dia.	Overall Length	Uncoated		nACRo® Coated	
D1 +.0000" +.000 mm -.0005" -.013 mm decimal equiv.			L2 +.015" -.000" +.38 mm -.00 mm	L3 +.010" -.010" +.25 mm -.00 mm	D3	D2 (h6)	L1	Tool #	Price	Tool #	Price	
.0600	.0600	.0600	.090	.200	.056	2	.1250	1.5	MEF-060-200	26.50	MEF-060-200K	30.60
.0600	.0600	.0600	.090	.200	.056	3	.1250	1.5	MEF-060-200-3	26.50	MEF-060-200-3K	30.60
.0600	.0600	.0600	.090	.350	.056	2	.1250	1.5	MEF-060-350	28.50	MEF-060-350K	32.60
.0600	.0600	.0600	.090	.350	.056	3	.1250	1.5	MEF-060-350-3	28.50		
.0600	.0600	.0600	.090	.500	.056	2	.1250	1.5	MEF-060-500	32.50	MEF-060-500K	36.60
.0600	.0600	.0600	.090	.500	.056	3	.1250	1.5	MEF-060-500-3	32.50	MEF-060-500-3K	36.60
.0600	.0600	.0600	.090	.750	.056	2	.1250	2.0	MEF-060-750	37.50	MEF-060-750K	41.60
.0600	.0600	.0600	.090	.750	.056	3	.1250	2.0	MEF-060-750-3	37.50	MEF-060-750-3K	41.60
.0625	.0625	.0625	.093	.200	.058	2	.1250	1.5	MEF-062-200	26.50	MEF-062-200K	30.60
.0625	.0625	.0625	.093	.200	.058	3	.1250	1.5	MEF-062-200-3	26.50	MEF-062-200-3K	30.60
.0625	.0625	.0625	.093	.350	.058	2	.1250	1.5	MEF-062-350	28.50	MEF-062-350K	32.60
.0625	.0625	.0625	.093	.350	.058	3	.1250	1.5	MEF-062-350-3	28.50	MEF-062-350-3K	32.60
.0625	.0625	.0625	.093	.550	.058	2	.1250	1.5	MEF-062-550	32.50	MEF-062-550K	36.60
.0625	.0625	.0625	.093	.550	.058	3	.1250	1.5	MEF-062-550-3	32.50		
.0625	.0625	.0625	.093	.750	.058	2	.1250	2.0	MEF-062-750	37.50	MEF-062-750K	41.60
.0625	.0625	.0625	.093	.750	.058	3	.1250	2.0	MEF-062-750-3	37.50	MEF-062-750-3K	41.60
.0750	.0750	.0750	.113	.250	.071	2	.1250	1.5	MEF-075-250	26.50	MEF-075-250K	30.60
.0750	.0750	.0750	.113	.250	.071	3	.1250	1.5	MEF-075-250-3	26.50	MEF-075-250-3K	30.60
.0750	.0750	.0750	.113	.400	.071	2	.1250	1.5	MEF-075-400	28.50	MEF-075-400K	32.60
.0750	.0750	.0750	.113	.400	.071	3	.1250	1.5	MEF-075-400-3	28.50	MEF-075-400-3K	32.60
.0750	.0750	.0750	.113	.600	.071	2	.1250	2.0	MEF-075-600	32.50	MEF-075-600K	36.60
.0750	.0750	.0750	.113	.600	.071	3	.1250	2.0	MEF-075-600-3	32.50	MEF-075-600-3K	36.60
.0750	.0750	.0750	.113	.900	.071	2	.1250	2.0	MEF-075-900	39.00	MEF-075-900K	43.10
.0750	.0750	.0750	.113	.900	.071	3	.1250	2.0	MEF-075-900-3	39.00	MEF-075-900-3K	43.10
.0781	.0781	.0781	.117	.250	.074	2	.1250	1.5	MEF-078-250	26.50	MEF-078-250K	30.60
.0781	.0781	.0781	.117	.250	.074	3	.1250	1.5	MEF-078-250-3	26.50	MEF-078-250-3K	30.60
.0781	.0781	.0781	.117	.400	.074	2	.1250	1.5	MEF-078-400	28.50	MEF-078-400K	32.60
.0781	.0781	.0781	.117	.400	.074	3	.1250	1.5	MEF-078-400-3	28.50		
.0781	.0781	.0781	.117	.650	.074	2	.1250	2.0	MEF-078-650	32.50	MEF-078-650K	36.60
.0781	.0781	.0781	.117	.650	.074	3	.1250	2.0	MEF-078-650-3	32.50	MEF-078-650-3K	36.60
.0781	.0781	.0781	.117	.900	.074	2	.1250	2.0	MEF-078-900	39.00	MEF-078-900K	43.10
.0781	.0781	.0781	.117	.900	.074	3	.1250	2.0	MEF-078-900-3	39.00	MEF-078-900-3K	43.10
2 mm	.0787	.0787	2.5 mm	7 mm	1.9 mm	2	3 mm	38 mm	MEFM-020-700	31.00	MEFM-020-700K	35.10
2 mm	.0787	.0787	2.5 mm	12 mm	1.9 mm	2	3 mm	38 mm	MEFM-020-1200	37.75	MEFM-020-1200K	41.85
2 mm	.0787	.0787	2.5 mm	16 mm	1.9 mm	2	3 mm	38 mm	MEFM-020-1600	40.00	MEFM-020-1600K	44.10
2 mm	.0787	.0787	2.5 mm	20 mm	1.9 mm	2	3 mm	50 mm	MEFM-020-2000	50.00	MEFM-020-2000K	54.10
2 mm	.0787	.0787	2.5 mm	25 mm	1.9 mm	2	3 mm	50 mm	MEFM-020-2500	57.00	MEFM-020-2500K	61.10
.0900	.0900	.0900	.125	.250	.086	2	.1250	1.5	MEF-090-250	26.50	MEF-090-250K	30.60
.0900	.0900	.0900	.125	.400	.086	2	.1250	1.5	MEF-090-400	28.50	MEF-090-400K	32.60
.0900	.0900	.0900	.125	.900	.086	2	.1250	2.0	MEF-090-900	35.50	MEF-090-900K	39.60
.0938	.0938	.0938	.125	.250	.089	2	.1250	1.5	MEF-093-250	26.50		
.0938	.0938	.0938	.125	.500	.089	2	.1250	1.5	MEF-093-500	28.50	MEF-093-500K	32.60
.0938	.0938	.0938	.125	.750	.089	2	.1250	2.0	MEF-093-750	32.50	MEF-093-750K	36.60
.0938	.0938	.0938	.125	1.000	.089	2	.1250	2.0	MEF-093-1000	37.50	MEF-093-1000K	41.60
2.5 mm	.0984	.0984	3 mm	10 mm	2.4 mm	2	3 mm	38 mm	MEFM-025-1000	34.50	MEFM-025-1000K	38.60

\*.0005" / .013 mm max TIR

Continued on next page

Steels & High Temp. Alloys

# End Mills For Steels & High Temperature Alloys

## Square – 2 & 3 Flute – Long Reach, Stub Flute (cont.)

MEF / MEFM

Steels & High Temp. Alloys

Continued from previous page

Cutter Diameter*			Length of Cut	Overall Reach	Neck Dia.	Flutes	Shank Dia.	Overall Length	Uncoated		nACRo® Coated		
D1		decimal equiv.	L2	L3	D3		D2 (h6)	L1	Tool #	Price	Tool #	Price	
+ .0000" / - .0005"	+ .000 mm / - .013 mm		+ .015" / - .000"	+ .010" / - .010"									
			+ .38 mm / - .00 mm	+ .25 mm / - .00 mm									
2.5 mm	.0984		3 mm	20 mm	2.4 mm	2	3 mm	50 mm	MEFM-025-2000	50.00	MEFM-025-2000K	54.10	
2.5 mm	.0984		3 mm	25 mm	2.4 mm	2	3 mm	50 mm	MEFM-025-2500	57.00	MEFM-025-2500K	61.10	
3 mm	.1181		3 mm	15 mm	2.9 mm	2	6 mm	57 mm	MEFM-030-1500	40.95	MEFM-030-1500K	48.15	
3 mm	.1181		3 mm	30 mm	2.9 mm	2	6 mm	57 mm	MEFM-030-3000	54.95	MEFM-030-3000K	62.15	
.1250	.1250		.125	.375	.121	2	.1875	2.0			MEF-125-375K	33.10	
.1250	.1250		.125	.750	.121	2	.1875	2.0	MEF-125-750	34.50	MEF-125-750K	39.10	
.1250	.1250		.125	1.000	.121	2	.1875	2.0	MEF-125-1000	37.50	MEF-125-1000K	42.10	
.1250	.1250		.125	1.500	.121	2	.1875	3.0	MEF-125-1500	42.95	MEF-125-1500K	48.85	
4 mm	.1575		5 mm	30 mm	3.9 mm	2	6 mm	57 mm	MEFM-040-3000	54.95	MEFM-040-3000K	62.15	
.1875	.1875		.200	1.000	.183	2	.2500	2.5			MEF-187-1000K	55.15	
.1875	.1875		.200	1.500	.183	2	.2500	2.5	MEF-187-1500	54.95	MEF-187-1500K	62.25	
.1875	.1875		.200	.500	.183	2	.2500	2.5	MEF-187-500	34.75	MEF-187-500K	41.95	
.1875	.1875		.200	.750	.183	2	.2500	2.5	MEF-187-750	40.95	MEF-187-750K	48.15	
5 mm	.1969		6 mm	25 mm	4.9 mm	2	6 mm	57 mm	MEFM-050-2500	47.95	MEFM-050-2500K	55.15	
5 mm	.1969		6 mm	30 mm	4.9 mm	2	6 mm	57 mm	MEFM-050-3000	54.95	MEFM-050-3000K	62.15	
D1	+ .0000" / - .0010"	decimal equiv.	L2	+ .015" / - .000"	L3	+ .010" / - .010"	D3	D2 (h6)	L1	Tool #	Price	Tool #	Price
.2500	.2500		.250	1.000	.246	2	.2500	2.5	MEF-250-1000	47.95	MEF-250-1000K	55.15	
.2500	.2500		.250	1.500	.246	2	.2500	3.0	MEF-250-1500	54.95			
.2500	.2500		.250	.750	.246	2	.2500	2.5	MEF-250-750	40.95	MEF-250-750K	48.15	

\*.0005" / .013 mm max TIR

SDH / SDHM

End Mills For Steels & High Temperature Alloys  
Square – 3 & 4 Flute

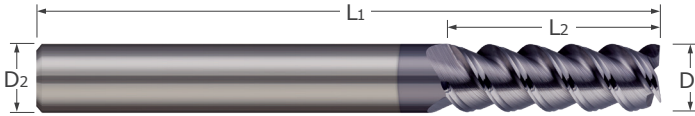

- Designed for high performance in titanium alloys, inconel, nickel alloys, and other high-temperature materials with outstanding performance in difficult-to-machine steels, stainless steels, and tool steels
- 60° high helix for reduced cutting forces and increased material removal rates
- Square profile ■ Center cutting
- AlTiN coating option for added lubricity and increased wear resistance in difficult-to-machine materials
- Solid carbide ■ CNC ground in the USA

Cutter Diameter*			Length of Cut	Flutes	Shank Diameter	Overall Length	Uncoated		AlTiN Coated	
D1 + .0000" - .0030" (h9)	decimal equiv.	L2 + .030" - .000" + .78 mm - .00 mm					D2 (h6)	L1	Tool #	Price
6 mm	.2362	18 mm	3	6 mm	57 mm	SDHM-060-3	21.75			
.2500	.2500	.750	3	.2500	2.5	SDH-250-03	26.45	SDH-250-03X	31.35	
.2813	.2813	.750	3	.3125	2.5	SDH-281-03	30.70			
10 mm	.3937	25 mm	4	10 mm	72 mm	SDHM-100-4	31.70			
.4375	.4375	1.000	3	.4375	2.5			SDH-437-03X	63.40	
12 mm	.4724	30 mm	3	12 mm	83 mm	SDHM-120-3	50.50	SDHM-120-3X	60.80	
12 mm	.4724	30 mm	4	12 mm	83 mm	SDHM-120-4	50.50	SDHM-120-4X	60.80	
.5000	.5000	1.000	3	.5000	3.0	SDH-500-03	60.65			
.5000	.5000	1.000	4	.5000	3.0	SDH-500-04	60.65	SDH-500-04X	68.85	
14 mm	.5512	35 mm	3	14 mm	83 mm	SDHM-140-3	61.60			
16 mm	.6299	35 mm	3	16 mm	92 mm			SDHM-160-3X	110.65	
19 mm	.7087	45 mm	3	18 mm	92 mm	SDHM-180-3	132.05	SDHM-180-3X	146.35	
19 mm	.7087	45 mm	4	18 mm	92 mm	SDHM-180-4	132.05	SDHM-180-4X	146.35	
20 mm	.7874	45 mm	3	20 mm	104 mm			SDHM-200-3X	188.40	
20 mm	.7874	45 mm	4	20 mm	104 mm	SDHM-200-4	168.40			
1.0000	1.0000	1.500	3	1.0000	4.0			SDH-000-03X	267.20	

\*.0005" / .013 mm max TIR

# End Mills For Steels & High Temperature Alloys

## Square – 4 Flute – Chipbreaker Rougher

SHR / SHRM  
SHL / SHLM

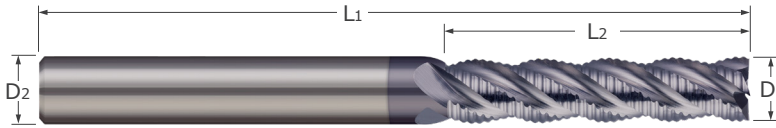

Steels & High Temp. Alloys

- Designed for roughing in titanium alloys, inconel, nickel alloys, and other high-temperature materials with outstanding performance in difficult-to-machine steels, stainless steels, and tool steels
- Integrated chipbreaker geometry generates increased material removal rates
- Available in standard and long length of cut options
- Weldon flat featured on sizes 3/8" and larger
- Square profile ■ 38° helix ■ Center cutting
- AlTiN coating option for added lubricity and increased wear resistance in difficult-to-machine materials
- Solid carbide ■ CNC ground in the USA

Cutter Diameter*			Length of Cut L2	Flutes	Shank Dia. D2 (h6)	Overall Length L1	Uncoated		AlTiN Coated	
D1 +.0000" -.0030" (h9)	decimal equiv.	Tool #					Price	Tool #	Price	
6 mm	.2362	16 mm	4	6 mm	57 mm	SHRM-060-4	36.10	SHRM-060-4X	41.00	
6 mm	.2362	25 mm	4	6 mm	75 mm	SHLM-060-4	46.10	SHLM-060-4X	51.00	
.2500	.2500	.750	4	.2500	2.5			SHR-250-4X	41.55	
.2500	.2500	1.125	4	.2500	3.0	SHL-250-4	46.90	SHL-250-4X	51.80	
.3125	.3125	.813	4	.3125	2.5			SHR-312-4X	47.70	
.3125	.3125	1.125	4	.3125	3.0			SHL-312-4X	59.40	
8 mm	.3150	22 mm	4	8 mm	63 mm			SHRM-080-4X	48.80	
8 mm	.3150	30 mm	4	8 mm	75 mm	SHLM-080-4	52.90	SHLM-080-4X	59.70	
.3750	.3750	.875	4	.3750	2.5	SHR-375-4	51.50	SHR-375-4X	58.30	
.3750	.3750	1.250	4	.3750	3.0			SHL-375-4X	73.40	
10 mm	.3937	25 mm	4	10 mm	72 mm			SHRM-100-4X	63.35	
10 mm	.3937	38 mm	4	10 mm	100 mm	SHLM-100-4	69.35	SHLM-100-4X	77.75	
12 mm	.4724	30 mm	4	12 mm	83 mm			SHRM-120-4X	82.55	
12 mm	.4724	50 mm	4	12 mm	100 mm	SHLM-120-4	93.20	SHLM-120-4X	106.25	
.5000	.5000	1.000	4	.5000	3.0	SHR-500-4	75.30	SHR-500-4X	83.50	
.5000	.5000	2.000	4	.5000	4.5			SHL-500-4X	107.00	
14 mm	.5512	35 mm	4	14 mm	83 mm	SHRM-140-4	120.60	SHRM-140-4X	132.00	
.6250	.6250	1.250	4	.6250	3.5	SHR-625-4	133.70	SHR-625-4X	146.10	
.6250	.6250	2.500	4	.6250	5.0			SHL-625-4X	184.20	
16 mm	.6299	35 mm	4	16 mm	92 mm			SHRM-160-4X	146.65	
16 mm	.6299	75 mm	4	16 mm	150 mm	SHLM-160-4	170.95	SHLM-160-4X	188.35	
18 mm	.7087	75 mm	4	20 mm	150 mm			SHLM-180-4X	260.90	
.7500	.7500	1.500	4	.7500	4.0			SHR-750-4X	201.70	
.7500	.7500	2.500	4	.7500	5.0	SHL-750-4	238.25	SHL-750-4X	255.25	
20 mm	.7874	45 mm	4	20 mm	104 mm			SHRM-200-4X	242.15	
20 mm	.7874	75 mm	4	20 mm	150 mm			SHLM-200-4X	308.15	
25 mm	.9843	50 mm	4	25 mm	127 mm			SHRM-250-4X	278.40	
1.0000	1.0000	1.500	4	1.0000	4.0			SHR-001-4X	274.60	
1.0000	1.0000	2.750	4	1.0000	5.0			SHL-001-4X	346.75	

\*.0005" / .013 mm max TIR

ASM / ASMM

End Mills For Steels & High Temperature Alloys

Square – 5 Flute – Stub Flute

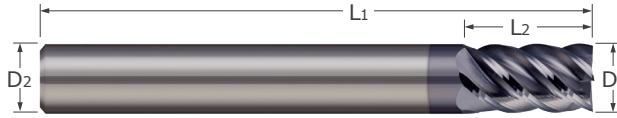

- Designed for applications in titanium alloys, inconel, nickel alloys, and other high-temperature materials with outstanding performance in difficult-to-machine steels, stainless steels, and tool steels
- 45° high helix for reduced cutting forces and increased material removal rates
- Stub flutes for maximum rigidity
- Square profile ■ Center cutting
- AlTiN coating option for added lubricity and increased wear resistance in difficult-to-machine materials
- Solid carbide ■ CNC ground in the USA

Cutter Diameter*			Length of Cut	Flutes	Shank Dia.	Overall Length	Uncoated		AlTiN Coated	
D1 +.0000" -.0020" (h9) decimal equiv.			L2 +.031" -.000" +.79 mm -.00 mm		D2 (h6)	L1	Tool #	Price	Tool #	Price
3 mm		.1181	6 mm	5	6 mm	57 mm	ASMM-030-5	25.85	ASMM-030-5X	30.75
4 mm		.1575	8 mm	5	6 mm	57 mm	ASMM-040-5	25.85	ASMM-040-5X	30.75
.1875		.1875	.375	5	.1875	1.5	ASM-187-5	20.80		
5 mm		.1969	10 mm	5	6 mm	57 mm	ASMM-050-5	25.85	ASMM-050-5X	30.75
6 mm		.2362	10 mm	5	6 mm	57 mm	ASMM-060-5	25.85		
.2500		.2500	.500	5	.2500	2.0	ASM-250-5	24.50		

D1 +.0000" -.0030" (h9) decimal equiv.			L2 +.031" -.000" +.79 mm -.00 mm		D2 (h6)	L1	Tool #	Price	Tool #	Price
.3125		.3125	.500	5	.3125	2.0	ASM-312-5	28.75		
8 mm		.3150	16 mm	5	8 mm	63 mm	ASMM-080-5	30.60	ASMM-080-5X	37.40
.3750		.3750	.625	5	.3750	2.0	ASM-375-5	35.75	ASM-375-5X	40.95
10 mm		.3937	19 mm	5	10 mm	72 mm	ASMM-100-5	36.20	ASMM-100-5X	43.00
12 mm		.4724	22 mm	5	12 mm	83 mm	ASMM-120-5	57.60	ASMM-120-5X	67.90
.5000		.5000	.625	5	.5000	2.0	ASM-500-5	56.20	ASM-500-5X	64.30

\*.0005" / .013 mm max TIR

# End Mills For Steels & High Temperature Alloys

## Square – 5 Flute

ARM / ARMM

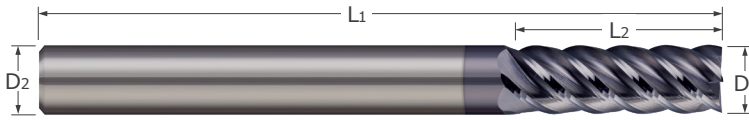

Steels & High Temp. Alloys

- Designed for applications in titanium alloys, inconel, nickel alloys, and other high-temperature materials with outstanding performance in difficult-to-machine steels, stainless steels, and tool steels
- 45° high helix for reduced cutting forces and increased material removal rates
- Square profile ■ Center cutting
- AlTiN coating option for added lubricity and increased wear resistance in difficult-to-machine materials
- Solid carbide ■ CNC ground in the USA

Cutter Diameter*			Length of Cut	Flutes	Shank Dia.	Overall Length	Uncoated		AlTiN Coated	
D1 +.0000" -.0020" (h8) decimal equiv.			L2 +.031" -.000" +.79 mm -.00 mm		D2 (h6)	L1	Tool #	Price	Tool #	Price
3 mm	.1181		10 mm	5	6 mm	57 mm	ARMM-030-5	27.20		
4 mm	.1575		15 mm	5	6 mm	57 mm	ARMM-040-5	27.20	ARMM-040-5X	32.10
.1875	.1875		.625	5	.1875	2.0	ARM-187-5	23.05		
6 mm	.2362		20 mm	5	6 mm	57 mm	ARMM-060-5	27.20	ARMM-060-5X	32.10
.2500	.2500		.750	5	.2500	2.5	ARM-250-5	28.90	ARM-250-5X	33.80
8 mm	.3150		25 mm	5	8 mm	63 mm	ARMM-080-5	32.25		

D1 +.0000" -.0030" (h8) decimal equiv.			L2 +.031" -.000" +.79 mm -.00 mm		D2 (h6)	L1	Tool #	Price	Tool #	Price
.3750	.3750		.875	5	.3750	2.5	ARM-375-5	38.10		
10 mm	.3937		25 mm	5	10 mm	72 mm	ARMM-100-5	38.00	ARMM-100-5X	44.80
.5000	.5000		1.000	5	.5000	3.0	ARM-500-5	63.45	ARM-500-5X	71.65
14 mm	.5512		30 mm	5	14 mm	83 mm			ARMM-140-5X	99.40
16 mm	.6299		35 mm	5	16 mm	92 mm			ARMM-160-5X	124.65
18 mm	.7087		45 mm	5	18 mm	92 mm	ARMM-180-5	150.80	ARMM-180-5X	165.10

\*.0005" / .013 mm max TIR



VHS /VHM

End Mills For Steels & High Temperature Alloys

Square – 5 Flute – Variable Helix

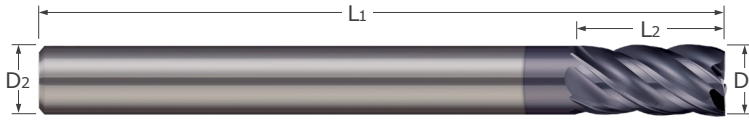

- Designed for high performance in titanium alloys, inconel, nickel alloys, and other high-temperature materials with outstanding performance in difficult-to-machine steels, stainless steels, and tool steels
- Variable helix design reduces chatter and harmonics and increases material removal rates
- Square profile ■ Center cutting
- nACRo® coating option for added heat resistance in difficult to machine materials
- Solid carbide ■ CNC ground in the USA

Cutter Diameter	Length of Cut	Flutes	Shank Diameter	Overall Length	Uncoated		nACRo® Coated	
					Tool #	Price	Tool #	Price
D1 $\begin{matrix} +.0000'' \\ -.0020'' \end{matrix}$	L2 $\begin{matrix} +.015'' \\ -.000'' \end{matrix}$		D2 (h6)	L1				
.2500	.500	5	.2500	2.5			VHS-250-5K	31.10
.2500	.750	5	.2500	2.5	VHM-250-5	29.50	VHM-250-5K	36.70
D1 $\begin{matrix} +.0000'' \\ -.0030'' \end{matrix}$	L2 $\begin{matrix} +.015'' \\ -.000'' \end{matrix}$		D2 (h6)	L1	Tool #	Price	Tool #	Price
.3125	.500	5	.3125	2.5	VHS-312-5	33.10		
.3125	.813	5	.3125	2.5	VHM-312-5	37.00		
.3750	.875	5	.3750	2.5			VHM-375-5K	50.30
.5000	.625	5	.5000	3.0			VHS-500-5K	71.30
.5000	1.000	5	.5000	3.0	VHM-500-5	66.00	VHM-500-5K	77.80
.5000	1.250	5	.5000	3.5	VHM-5125-5	69.30	VHM-5125-5K	81.20
.6250	1.250	5	.6250	3.5			VHM-625-5K	141.65
.7500	1.500	5	.7500	4.0	VHM-750-5	183.00		

Steels & High Temp. Alloys

## End Mills For Steels & High Temperature Alloys

VLM

Square – 5 Flute – Variable Helix – Long Flute

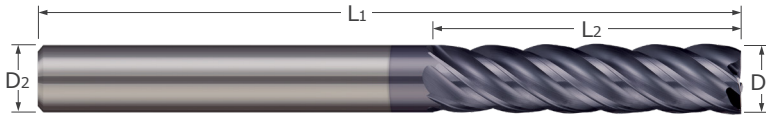

- Designed for high performance in titanium alloys, inconel, nickel alloys, and other high-temperature materials with outstanding performance in difficult-to-machine steels, stainless steels, and tool steels
- Variable helix design reduces chatter and harmonics and increases material removal rates
- Specialized geometry for maximum performance in high velocity tool paths
- Weldon flat offered on sizes 3/8" and larger
- Square profile
- Center cutting
- nACRo® coating option for added heat resistance in difficult to machine materials
- Solid carbide
- CNC ground in the USA

Steels & High Temp. Alloys

Cutter Diameter	Length of Cut	Flutes	Shank Diameter	Overall Length	Uncoated		nACRo® Coated	
					Tool #	Price	Tool #	Price
D1 $+0.0000''$ $-0.0030''$	L2 $+0.015''$ $-0.000''$		D2 (h6)	L1				
.3125	1.125	5	.3125	3.0	VLM-312-5	41.50		
.3750	1.250	5	.3750	3.0	VLM-375-5	50.50	VLM-375-5K	60.30
.5000	1.750	5	.5000	4.5	VLM-500-5	85.50	VLM-500-5K	102.60
.6250	2.250	5	.6250	5.0	VLM-625-5	156.50		

## End Mills For Steels & High Temperature Alloys

VLR

Square – 5 Flute – Variable Helix – Long Reach

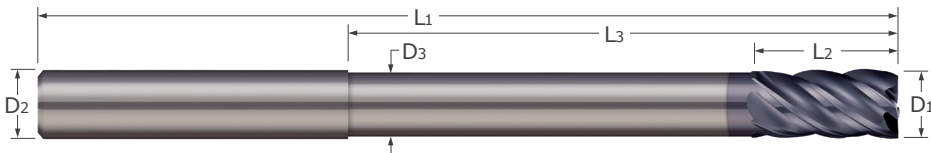

- Designed for high performance in titanium alloys, inconel, nickel alloys, and other high-temperature materials with outstanding performance in difficult-to-machine steels, stainless steels, and tool steels
- Variable helix design reduces chatter and harmonics and increases material removal rates
- Specialized geometry for maximum performance in high velocity tool paths
- Long reach for deep pocket milling
- Square profile
- Weldon flat offered on sizes 3/8" and larger
- Center cutting
- nACRo® coating option for added heat resistance in difficult to machine materials
- Solid carbide
- CNC ground in the USA

Cutter Diameter	Length of Cut	Overall Reach	Neck Diameter	Flutes	Shank Diameter	Overall Length	Uncoated		nACRo® Coated	
							Tool #	Price	Tool #	Price
D1 $+0.0000''$ $-0.0020''$	L2 $+0.010''$ $-0.000''$	L3 $+0.015''$ $-0.000''$	D3		D2 (h6)	L1				
.2500	.500	2.500	.230	5	.2500	4.0	VLR-250-5	47.95		
.3125	.625	2.625	.292	5	.3125	4.0	VLR-312-5	51.00	VLR-312-5K	63.10
.3750	.750	2.750	.355	5	.3750	4.0	VLR-375-5	70.50	VLR-375-5K	82.60

## EMH / EMHM

## End Mills For Steels & High Temperature Alloys

### Square – 4 & 6 Flute

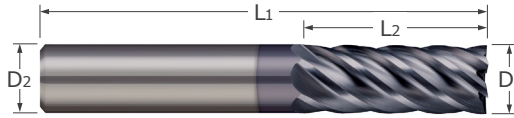

- Designed for finishing in titanium alloys, inconel, nickel alloys, and other high-temperature materials with outstanding performance in difficult-to-machine steels, stainless steels, and tool steels
- 38° helix for superior surface finish
- Square profile
- Weldon flat featured on sizes 3/8" and larger on ANSI shanks only
- Center cutting
- AlTiN coating option for added lubricity and increased wear resistance in difficult-to-machine materials
- Solid carbide ■ CNC ground in the USA

Cutter Diameter*		Length of Cut	Flutes	Shank Dia.	Overall Length	Uncoated		AlTiN Coated	
D <sub>1</sub> +.0000" -.0002" (h8)	decimal equiv.	L <sub>2</sub> +.030" -.000" +.78 mm -.00 mm		D <sub>2</sub> (h6)	L <sub>1</sub>	Tool #	Price	Tool #	Price
3 mm	.1181	8 mm	4	4 mm	50 mm	EMHM-030-4	17.35		
4 mm	.1574	12 mm	4	4 mm	50 mm	EMHM-040-4	17.35	EMHM-040-4X	20.25
6 mm	.2362	18 mm	4	6 mm	57 mm	EMHM-060-4	21.75	EMHM-060-4X	26.65
6 mm	.2362	18 mm	6	6 mm	57 mm	EMHM-060-6	21.75	EMHM-060-6X	26.65

D <sub>1</sub> +.0000" -.0003" (h8)	decimal equiv.	L <sub>2</sub> +.030" -.000" +.78 mm -.00 mm		D <sub>2</sub> (h6)	L <sub>1</sub>	Tool #	Price	Tool #	Price
.2813	.2813	.750	6	.3125	2.5	EMH-281-06	33.60	EMH-281-06X	40.40
.3125	.3125	.813	6	.3125	2.5	EMH-312-06	33.60	EMH-312-06X	40.40
8 mm	.3150	20 mm	4	8 mm	63 mm	EMHM-080-4	26.90	EMHM-080-4X	33.70
8 mm	.3150	20 mm	6	8 mm	63 mm	EMHM-080-6	26.90	EMHM-080-6X	33.70
10 mm	.3937	22 mm	4	10 mm	72 mm	EMHM-100-4	31.70		
10 mm	.3937	22 mm	6	10 mm	72 mm			EMHM-100-6X	38.50
12 mm	.4724	25 mm	4	12 mm	83 mm			EMHM-120-4X	60.80
12 mm	.4724	25 mm	6	12 mm	83 mm	EMHM-120-6	50.50	EMHM-120-6X	60.80
.5000	.5000	1.000	6	.5000	3.0	EMH-500-06	66.00	EMH-500-06X	74.20
14 mm	.5512	30 mm	6	14 mm	83 mm	EMHM-140-6	61.60	EMHM-140-6X	73.00
.6250	.6250	1.250	6	.6250	3.5	EMH-625-06	116.75		
16 mm	.6299	35 mm	6	16 mm	92 mm			EMHM-160-6X	110.65
18 mm	.7086	45 mm	6	18 mm	92 mm			EMHM-180-6X	146.35
.7500	.7500	1.500	6	.7500	4.0			EMH-750-06X	192.30
20 mm	.7874	45 mm	6	20 mm	104 mm			EMHM-200-6X	188.40
1.0000	1.0000	1.500	6	1.0000	4.0	EMH-000-06	269.60		

\*.0005" / .013 mm max TIR

# End Mills For Steels & High Temperature Alloys

BEF / BEFM

## Ball – 2 & 3 Flute – Stub Flute

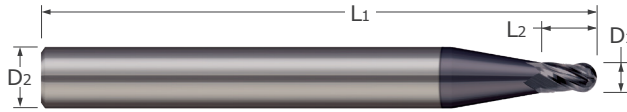

- Designed for high performance in titanium alloys, inconel, nickel alloys, and other high-temperature materials with outstanding performance in difficult-to-machine steels, stainless steels, and tool steels
- Stub flutes for maximum rigidity
- Ball profile
- 20° helix
- Center cutting
- nACRo® coating option for added heat resistance in difficult to machine materials
- Solid carbide ■ CNC ground in the USA

Steels & High Temp. Alloys

Cutter Diameter*			Length of Cut	Flutes	Shank Diameter	Overall Length	Uncoated		nACRo® Coated	
D1 +.0000" -.0005"	+.000 mm -.013 mm	decimal equiv.	L2 +.015" -.000" +.38 mm -.00 mm	D2 (h6)	L1	Tool #	Price	Tool #	Price	
0.2 mm		.0079	0.3 mm	2	3 mm	38 mm	BEFM-002-030	49.65	BEFM-002-030K	53.75
0.3 mm		.0118	0.45 mm	2	3 mm	38 mm	BEFM-003-045	44.25		
.0150		.0150	.023	2	.1250	1.5			BEF-015-023K	43.35
0.4 mm		.0157	0.6 mm	2	3 mm	38 mm	BEFM-004-060	39.25	BEFM-004-060K	43.35
0.5 mm		.0197	0.7 mm	2	3 mm	38 mm			BEFM-005-070K	31.85
.0200		.0200	.030	2	.1250	1.5	BEF-020-030	27.75	BEF-020-030K	31.85
.0200		.0200	.030	3	.1250	1.5	BEF-020-030-3	27.75	BEF-020-030-3K	31.85
0.6 mm		.0236	0.9 mm	2	3 mm	38 mm			BEFM-006-090K	31.85
.0250		.0250	.038	3	.1250	1.5	BEF-025-038-3	27.75	BEF-025-038-3K	31.85
.0300		.0300	.045	2	.1250	1.5			BEF-030-045K	29.60
.0313		.0313	.047	2	.1250	1.5	BEF-031-047	25.50	BEF-031-047K	29.60
.0313		.0313	.047	3	.1250	1.5	BEF-031-047-3	25.50		
0.8 mm		.0315	1.2 mm	2	3 mm	38 mm			BEFM-008-120K	29.60
.0350		.0350	.053	2	.1250	1.5	BEF-035-053	25.50	BEF-035-053K	29.60
.0350		.0350	.053	3	.1250	1.5	BEF-035-053-3	25.50	BEF-035-053-3K	29.60
1 mm		.0394	1.5 mm	2	3 mm	38 mm	BEFM-010-150	25.50	BEFM-010-150K	29.60
.0400		.0400	.060	2	.1250	1.5	BEF-040-060	25.50	BEF-040-060K	29.60
.0400		.0400	.060	3	.1250	1.5	BEF-040-060-3	25.50	BEF-040-060-3K	29.60
.0450		.0450	.068	2	.1250	1.5	BEF-045-068	25.50	BEF-045-068K	29.60
.0450		.0450	.068	3	.1250	1.5	BEF-045-068-3	25.50	BEF-045-068-3K	29.60
.0469		.0469	.071	2	.1250	1.5			BEF-047-071K	29.60
.0469		.0469	.071	3	.1250	1.5	BEF-047-071-3	25.50	BEF-047-071-3K	29.60
1.2 mm		.0472	1.8 mm	2	3 mm	38 mm			BEFM-012-180K	29.60
.0500		.0500	.075	2	.1250	1.5	BEF-050-075	25.50	BEF-050-075K	29.60
.0500		.0500	.075	3	.1250	1.5	BEF-050-075-3	25.50	BEF-050-075-3K	29.60
1.5 mm		.0591	2.2 mm	2	3 mm	38 mm			BEFM-015-220K	29.60
.0600		.0600	.090	2	.1250	1.5	BEF-060-090	25.50	BEF-060-090K	29.60
.0600		.0600	.090	3	.1250	1.5	BEF-060-090-3	25.50	BEF-060-090-3K	29.60

\*.0005" / .013 mm max TIR

Continued on next page

BEF / BEFM

End Mills For Steels & High Temperature Alloys

Ball – 2 & 3 Flute – Stub Flute (cont.)

Continued from previous page

Cutter Diameter*			Length of Cut	Flutes	Shank Diameter	Overall Length	Uncoated		nACRo® Coated	
D1			L2		D2 (h6)	L1	Tool #	Price	Tool #	Price
+ .0000" - .0005"	+ .000 mm - .013 mm	decimal equiv.	+ .015" - .000" + .38 mm - .00 mm							
.0625		.0625	.093	2	.1250	1.5	BEF-062-093	25.50	BEF-062-093K	29.60
.0625		.0625	.093	3	.1250	1.5	BEF-062-093-3	25.50		
.0750		.0750	.113	2	.1250	1.5	BEF-075-113	25.50	BEF-075-113K	29.60
.0750		.0750	.113	3	.1250	1.5	BEF-075-113-3	25.50	BEF-075-113-3K	29.60
.0781		.0781	.117	2	.1250	1.5			BEF-078-117K	29.60
.0781		.0781	.117	3	.1250	1.5	BEF-078-117-3	25.50	BEF-078-117-3K	29.60
	2 mm	.0787	2.5 mm	2	3 mm	38 mm			BEFM-020-250K	29.60
.0900		.0900	.125	2	.1250	1.5	BEF-090-125	25.50	BEF-090-125K	29.60
.0938		.0938	.125	2	.1250	1.5	BEF-093-125	25.50	BEF-093-125K	29.60
	2.5 mm	.0984	3 mm	2	3 mm	38 mm	BEFM-025-300	25.50	BEFM-025-300K	29.60
	3 mm	.1181	3 mm	2	6 mm	57 mm	BEFM-030-300	36.90	BEFM-030-300K	41.95
.1250		.1250	.125	2	.1875	2.0	BEF-125-125	27.50	BEF-125-125K	32.10
	4 mm	.1575	5 mm	2	6 mm	57 mm	BEFM-040-500	36.90	BEFM-040-500K	41.95
.1875		.1875	.200	2	.2500	2.5	BEF-187-250	36.90	BEF-187-250K	44.10
	5 mm	.1969	6 mm	2	6 mm	57 mm	BEFM-050-600	36.90	BEFM-050-600K	41.95
D1			L2		D2 (h6)	L1	Tool #	Price	Tool #	Price
+ .0000" - .0010"	decimal equiv.		+ .015" - .000"							
.2500	.2500		.250	2	.2500	2.5	BEF-250-250	36.90		

\*.0005" / .013 mm max TIR

Steels & High Temp. Alloys

# End Mills For Steels & High Temperature Alloys

BEF / BEFM

## Ball – 2 & 3 Flute – Long Reach, Stub Flute

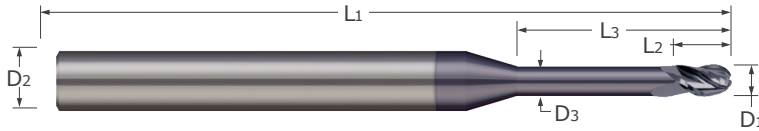

Steels & High Temp. Alloys

- Designed for high performance in titanium alloys, inconel, nickel alloys, and other high-temperature materials with outstanding performance in difficult-to-machine steels, stainless steels, and tool steels
- Long reach for deep pocket milling
- Stub flutes for maximum rigidity
- Reduced neck diameter to avoid heeling
- Ball profile ■ 20° helix ■ Center cutting
- nACRo® coating option for added heat resistance in difficult to machine materials
- Solid carbide ■ CNC ground in the USA

Cutter Diameter*			Length of Cut	Overall Reach	Neck Dia.	Flutes	Shank Dia.	Overall Length	Uncoated		nACRo® Coated	
D1 +.0000" +.000 mm -.0005" -.013 mm decimal equiv.	L2	L3	D2	D3	D2 (h6)	L1	Tool #	Price	Tool #	Price		
											+.015" -.000"	+.010" -.010"
.0150	.023	.100	.014	2	.1250	1.5	BEF-015-100	44.25	BEF-015-100K	48.35		
.0150	.023	.200	.014	2	.1250	1.5	BEF-015-200	45.25	BEF-015-200K	49.35		
.0150	.023	.200	.014	3	.1250	1.5	BEF-015-200-3	45.25				
.0150	.023	.200	.014	3	.1250	1.5			BEF-015-200-3K	49.35		
0.5 mm	0.7 mm	3 mm	0.45 mm	2	3 mm	38 mm	BEFM-005-300	32.75				
0.5 mm	0.7 mm	6 mm	0.45 mm	2	3 mm	38 mm	BEFM-005-600	35.00	BEFM-005-600K	39.10		
.0200	.030	.150	.019	2	.1250	1.5	BEF-020-150	32.75	BEF-020-150K	36.85		
.0200	.030	.150	.019	3	.1250	1.5	BEF-020-150-3	32.75	BEF-020-150-3K	36.85		
.0200	.030	.250	.019	2	.1250	1.5	BEF-020-250	33.75	BEF-020-250K	37.85		
.0200	.030	.250	.019	3	.1250	1.5	BEF-020-250-3	33.75	BEF-020-250-3K	37.85		
0.6 mm	0.9 mm	3 mm	0.55 mm	2	3 mm	38 mm	BEFM-006-300	32.75	BEFM-006-300K	36.85		
0.6 mm	0.9 mm	5 mm	0.55 mm	2	3 mm	38 mm	BEFM-006-500	33.75	BEFM-006-500K	37.85		
0.6 mm	0.9 mm	6 mm	0.55 mm	2	3 mm	38 mm	BEFM-006-600	35.00	BEFM-006-600K	39.10		
.0250	.038	.150	.024	2	.1250	1.5	BEF-025-150	32.75	BEF-025-150K	36.85		
.0250	.038	.150	.024	3	.1250	1.5	BEF-025-150-3	32.75	BEF-025-150-3K	36.85		
.0250	.038	.250	.024	2	.1250	1.5	BEF-025-250	33.75	BEF-025-250K	37.85		
.0250	.038	.250	.024	3	.1250	1.5	BEF-025-250-3	33.75	BEF-025-250-3K	37.85		
.0300	.045	.100	.028	2	.1250	1.5	BEF-030-100	30.50	BEF-030-100K	34.60		
.0300	.045	.100	.028	3	.1250	1.5	BEF-030-100-3	30.50	BEF-030-100-3K	34.60		
.0300	.045	.200	.028	2	.1250	1.5	BEF-030-200	31.50	BEF-030-200K	35.60		
.0300	.045	.200	.028	3	.1250	1.5	BEF-030-200-3	31.50	BEF-030-200-3K	35.60		
.0300	.045	.375	.028	2	.1250	1.5	BEF-030-375	31.50	BEF-030-375K	35.60		
.0300	.045	.375	.028	3	.1250	1.5	BEF-030-375-3	31.50	BEF-030-375-3K	35.60		
.0313	.047	.100	.029	2	.1250	1.5	BEF-031-100	30.50	BEF-031-100K	34.60		
.0313	.047	.100	.029	3	.1250	1.5	BEF-031-100-3	30.50	BEF-031-100-3K	34.60		
.0313	.047	.200	.029	2	.1250	1.5	BEF-031-200	31.50	BEF-031-200K	35.60		
.0313	.047	.200	.029	3	.1250	1.5	BEF-031-200-3	31.50	BEF-031-200-3K	35.60		
.0313	.047	.375	.029	2	.1250	1.5	BEF-031-375	34.50	BEF-031-375K	38.60		
.0313	.047	.375	.029	3	.1250	1.5	BEF-031-375-3	34.50	BEF-031-375-3K	38.60		

\*.0005" / .013 mm max TIR

Continued on next page

BEF / BEFM

End Mills For Steels & High Temperature Alloys

Ball - 2 & 3 Flute - Long Reach, Stub Flute (cont.)

Continued from previous page

Cutter Diameter*			Length of Cut	Overall Reach	Neck Dia.	Flutes	Shank Dia.	Overall Length	Uncoated		nACRo® Coated	
D1		decimal equiv.	L2	L3	D3		D2 (h6)	L1	Tool #	Price	Tool #	Price
+ .0000" - .0005"	+ .000 mm - .013 mm		+ .015" - .000"	+ .010" - .010"								
			+ .38 mm - .00 mm	+ .25 mm - .00 mm								
0.8 mm	.0315		1.2 mm	4 mm	0.75 mm	2	3 mm	38 mm	BEFM-008-400	30.50	BEFM-008-400K	34.60
0.8 mm	.0315		1.2 mm	7 mm	0.75 mm	2	3 mm	38 mm	BEFM-008-700	31.50	BEFM-008-700K	35.60
0.8 mm	.0315		1.2 mm	9 mm	0.75 mm	2	3 mm	38 mm	BEFM-008-900	34.50	BEFM-008-900K	38.60
.0350	.0350		.053	.150	.033	2	.1250	1.5	BEF-035-150	30.50	BEF-035-150K	34.60
.0350	.0350		.053	.150	.033	3	.1250	1.5	BEF-035-150-3	30.50	BEF-035-150-3K	34.60
.0350	.0350		.053	.250	.033	2	.1250	1.5	BEF-035-250	31.50	BEF-035-250K	35.60
.0350	.0350		.053	.250	.033	3	.1250	1.5	BEF-035-250-3	31.50	BEF-035-250-3K	35.60
.0350	.0350		.053	.400	.033	2	.1250	1.5	BEF-035-400	34.50	BEF-035-400K	38.60
.0350	.0350		.053	.400	.033	3	.1250	1.5	BEF-035-400-3	34.50	BEF-035-400-3K	38.60
1 mm	.0394		1.5 mm	7 mm	0.95 mm	2	3 mm	38 mm	BEFM-010-700	31.50	BEFM-010-700K	35.60
1 mm	.0394		1.5 mm	9 mm	0.95 mm	2	3 mm	38 mm	BEFM-010-900	34.50	BEFM-010-900K	38.60
.0400	.0400		.060	.150	.038	2	.1250	1.5	BEF-040-150	30.50	BEF-040-150K	34.60
.0400	.0400		.060	.150	.038	3	.1250	1.5	BEF-040-150-3	30.50	BEF-040-150-3K	34.60
.0400	.0400		.060	.250	.038	2	.1250	1.5	BEF-040-250	31.50	BEF-040-250K	35.60
.0400	.0400		.060	.250	.038	3	.1250	1.5	BEF-040-250-3	31.50	BEF-040-250-3K	35.60
.0400	.0400		.060	.500	.038	2	.1250	1.5	BEF-040-500	36.50	BEF-040-500K	40.60
.0400	.0400		.060	.500	.038	3	.1250	1.5	BEF-040-500-3	36.50	BEF-040-500-3K	40.60
.0450	.0450		.068	.150	.043	2	.1250	1.5	BEF-045-150	30.50	BEF-045-150K	34.60
.0450	.0450		.068	.150	.043	3	.1250	1.5	BEF-045-150-3	30.50	BEF-045-150-3K	34.60
.0450	.0450		.068	.250	.043	2	.1250	1.5	BEF-045-250	31.50	BEF-045-250K	35.60
.0450	.0450		.068	.250	.043	3	.1250	1.5	BEF-045-250-3	31.50	BEF-045-250-3K	35.60
.0450	.0450		.068	.500	.043	2	.1250	1.5	BEF-045-500	36.50	BEF-045-500K	40.60
.0450	.0450		.068	.500	.043	3	.1250	1.5	BEF-045-500-3	36.50	BEF-045-500-3K	40.60
.0469	.0469		.071	.150	.045	2	.1250	1.5	BEF-047-150	30.50	BEF-047-150K	34.60
.0469	.0469		.071	.150	.045	3	.1250	1.5	BEF-047-150-3	30.50	BEF-047-150-3K	34.60
.0469	.0469		.071	.250	.045	2	.1250	1.5	BEF-047-250	31.50	BEF-047-250K	35.60
.0469	.0469		.071	.250	.045	3	.1250	1.5	BEF-047-250-3	31.50	BEF-047-250-3K	35.60
.0469	.0469		.071	.500	.045	2	.1250	1.5	BEF-047-500	36.50	BEF-047-500K	40.60
.0469	.0469		.071	.500	.045	3	.1250	1.5	BEF-047-500-3	36.50	BEF-047-500-3K	40.60
1.2 mm	.0472		1.8 mm	6 mm	1.1 mm	2	3 mm	38 mm			BEFM-012-600K	35.60
1.2 mm	.0472		1.8 mm	10 mm	1.1 mm	2	3 mm	38 mm			BEFM-012-1000K	38.60
1.2 mm	.0472		1.8 mm	12 mm	1.1 mm	2	3 mm	38 mm	BEFM-012-1200	37.80	BEFM-012-1200K	41.90
.0500	.0500		.075	.200	.048	2	.1250	1.5	BEF-050-200	30.50	BEF-050-200K	34.60
.0500	.0500		.075	.200	.048	3	.1250	1.5	BEF-050-200-3	30.50	BEF-050-200-3K	34.60
.0500	.0500		.075	.300	.048	2	.1250	1.5	BEF-050-300	31.50	BEF-050-300K	35.60
.0500	.0500		.075	.300	.048	3	.1250	1.5	BEF-050-300-3	31.50	BEF-050-300-3K	35.60
.0500	.0500		.075	.550	.048	2	.1250	1.5			BEF-050-550K	40.60
.0500	.0500		.075	.550	.048	3	.1250	1.5	BEF-050-550-3	36.50	BEF-050-550-3K	40.60
1.5 mm	.0591		2.2 mm	6 mm	1.4 mm	2	3 mm	38 mm	BEFM-015-600	31.50	BEFM-015-600K	35.60
1.5 mm	.0591		2.2 mm	10 mm	1.4 mm	2	3 mm	38 mm	BEFM-015-1000	34.50	BEFM-015-1000K	38.60
1.5 mm	.0591		2.2 mm	12 mm	1.4 mm	2	3 mm	38 mm	BEFM-015-1200	37.80	BEFM-015-1200K	41.90
1.5 mm	.0591		2.2 mm	15 mm	1.4 mm	2	3 mm	38 mm	BEFM-015-1500	40.05	BEFM-015-1500K	44.15
1.5 mm	.0591		2.2 mm	20 mm	1.4 mm	2	3 mm	50 mm	BEFM-015-2000	50.00	BEFM-015-2000K	54.10

\*.0005" / .013 mm max TIR

Continued on next page

# End Mills For Steels & High Temperature Alloys

## Ball – 2 & 3 Flute – Long Reach, Stub Flute (cont.)

BEF / BEFM

Continued from previous page

Steels & High Temp. Alloys

Cutter Diameter*			Length of Cut	Overall Reach	Neck Dia.	Flutes	Shank Dia.	Overall Length	Uncoated		nACRo® Coated	
D1			L2	L3	D3	D2 (h6)	L1		Tool #	Price	Tool #	Price
+.0000"	+.000 mm	decimal equiv.	+ .015" -.000"	+ .010" -.010"								
-.0005"	-.013 mm		+ .38 mm -.00 mm	+ .25 mm -.00 mm								
.0600	.0600	.0600	.090	.200	.056	2	.1250	1.5	BEF-060-200	30.50	BEF-060-200K	34.60
.0600	.0600	.0600	.090	.200	.056	3	.1250	1.5	BEF-060-200-3	30.50	BEF-060-200-3K	34.60
.0600	.0600	.0600	.090	.350	.056	2	.1250	1.5	BEF-060-350	31.50	BEF-060-350K	35.60
.0600	.0600	.0600	.090	.350	.056	3	.1250	1.5	BEF-060-350-3	31.50	BEF-060-350-3K	35.60
.0600	.0600	.0600	.090	.500	.056	2	.1250	1.5	BEF-060-500	36.50	BEF-060-500K	40.60
.0600	.0600	.0600	.090	.500	.056	3	.1250	1.5	BEF-060-500-3	36.50	BEF-060-500-3K	40.60
.0600	.0600	.0600	.090	.750	.056	2	.1250	2.0	BEF-060-750	41.50		
.0600	.0600	.0600	.090	.750	.056	3	.1250	2.0	BEF-060-750-3	41.50	BEF-060-750-3K	45.60
.0625	.0625	.0625	.093	.200	.058	2	.1250	1.5			BEF-062-200K	34.60
.0625	.0625	.0625	.093	.200	.058	3	.1250	1.5	BEF-062-200-3	30.50	BEF-062-200-3K	34.60
.0625	.0625	.0625	.093	.350	.058	2	.1250	1.5	BEF-062-350	30.50		
.0625	.0625	.0625	.093	.350	.058	3	.1250	1.5			BEF-062-350-3K	34.60
.0625	.0625	.0625	.093	.550	.058	2	.1250	1.5	BEF-062-550	36.50	BEF-062-550K	40.60
.0625	.0625	.0625	.093	.550	.058	3	.1250	1.5	BEF-062-550-3	36.50	BEF-062-550-3K	40.60
.0625	.0625	.0625	.093	.750	.058	2	.1250	2.0	BEF-062-750	41.50	BEF-062-750K	45.60
.0625	.0625	.0625	.093	.750	.058	3	.1250	2.0	BEF-062-750-3	41.50	BEF-062-750-3K	45.60
.0750	.0750	.0750	.113	.250	.071	2	.1250	1.5	BEF-075-250	30.50	BEF-075-250K	34.60
.0750	.0750	.0750	.113	.250	.071	3	.1250	1.5	BEF-075-250-3	30.50	BEF-075-250-3K	34.60
.0750	.0750	.0750	.113	.400	.071	2	.1250	1.5	BEF-075-400	36.50	BEF-075-400K	40.60
.0750	.0750	.0750	.113	.400	.071	3	.1250	1.5	BEF-075-400-3	36.50	BEF-075-400-3K	40.60
.0750	.0750	.0750	.113	.600	.071	2	.1250	2.0	BEF-075-600	40.50	BEF-075-600K	44.60
.0750	.0750	.0750	.113	.600	.071	3	.1250	2.0	BEF-075-600-3	40.50	BEF-075-600-3K	44.60
.0750	.0750	.0750	.113	.900	.071	2	.1250	2.0	BEF-075-900	43.75	BEF-075-900K	47.85
.0750	.0750	.0750	.113	.900	.071	3	.1250	2.0	BEF-075-900-3	43.75	BEF-075-900-3K	47.85
.0781	.0781	.0781	.117	.250	.074	2	.1250	1.5	BEF-078-250	30.50	BEF-078-250K	34.60
.0781	.0781	.0781	.117	.250	.074	3	.1250	1.5	BEF-078-250-3	30.50	BEF-078-250-3K	34.60
.0781	.0781	.0781	.117	.400	.074	2	.1250	1.5	BEF-078-400	36.50	BEF-078-400K	40.60
.0781	.0781	.0781	.117	.400	.074	3	.1250	1.5	BEF-078-400-3	36.50	BEF-078-400-3K	40.60
.0781	.0781	.0781	.117	.650	.074	2	.1250	2.0	BEF-078-650	40.50	BEF-078-650K	44.60
.0781	.0781	.0781	.117	.650	.074	3	.1250	2.0	BEF-078-650-3	40.50	BEF-078-650-3K	44.60
.0781	.0781	.0781	.117	.900	.074	2	.1250	2.0	BEF-078-900	43.75	BEF-078-900K	47.85
.0781	.0781	.0781	.117	.900	.074	3	.1250	2.0	BEF-078-900-3	43.75	BEF-078-900-3K	47.85
2 mm	.0787		2.5 mm	7 mm	1.9 mm	2	3 mm	38 mm	BEFM-020-700	31.50	BEFM-020-700K	35.60
2 mm	.0787		2.5 mm	12 mm	1.9 mm	2	3 mm	38 mm	BEFM-020-1200	37.80	BEFM-020-1200K	41.90
2 mm	.0787		2.5 mm	16 mm	1.9 mm	2	3 mm	38 mm	BEFM-020-1600	40.05	BEFM-020-1600K	44.15
2 mm	.0787		2.5 mm	20 mm	1.9 mm	2	3 mm	50 mm	BEFM-020-2000	50.00	BEFM-020-2000K	54.10
2 mm	.0787		2.5 mm	25 mm	1.9 mm	2	3 mm	50 mm	BEFM-020-2500	55.50	BEFM-020-2500K	59.60
.0900	.0900	.0900	.125	.250	.086	2	.1250	1.5	BEF-090-250	30.50	BEF-090-250K	34.60
.0900	.0900	.0900	.125	.400	.086	2	.1250	1.5	BEF-090-400	36.50	BEF-090-400K	40.60
.0900	.0900	.0900	.125	.400	.086	3	.1250	1.5	BEF-090-400-3	36.50		
.0900	.0900	.0900	.125	.650	.086	3	.1250	1.5			BEF-090-400-3K	40.60
.0900	.0900	.0900	.125	.650	.086	2	.1250	2.0	BEF-090-650	40.50		
.0900	.0900	.0900	.125	.650	.086	3	.1250	2.0	BEF-090-650-3	40.50		
.0900	.0900	.0900	.125	.650	.086	3	.1250	2.0			BEF-090-650-3K	44.60
.0900	.0900	.0900	.125	.900	.086	2	.1250	2.0	BEF-090-900	41.50	BEF-090-900K	45.60

\*.0005" / .013 mm max TIR

Continued on next page



BEF / BEFM

End Mills For Steels & High Temperature Alloys

Ball - 2 & 3 Flute - Long Reach, Stub Flute (cont.)

Continued from previous page

Cutter Diameter*			Length of Cut	Overall Reach	Neck Dia.	Flutes	Shank Dia.	Overall Length	Uncoated		nACRo® Coated	
D1 +.0000" -.0005"	+.000 mm -.013 mm	decimal equiv.	L2	L3	D3	D2 (h6)	L1	Tool #	Price	Tool #	Price	
			+.015" -.000"	+.010" -.010"								
.0938	.0938	.0938	.125	.250	.089	2	.1250	1.5	BEF-093-250	30.50	BEF-093-250K	34.60
.0938	.0938	.0938	.125	.500	.089	2	.1250	1.5	BEF-093-500	36.50	BEF-093-500K	40.60
.0938	.0938	.0938	.125	.750	.089	2	.1250	2.0	BEF-093-750	41.50	BEF-093-750K	45.60
.0938	.0938	.0938	.125	1.000	.089	2	.1250	2.0	BEF-093-1000	43.75	BEF-093-1000K	47.85
2.5 mm	.0984	.0984	3 mm	10 mm	2.4 mm	2	3 mm	38 mm	BEFM-025-1000	34.50	BEFM-025-1000K	38.60
2.5 mm	.0984	.0984	3 mm	15 mm	2.4 mm	2	3 mm	38 mm	BEFM-025-1500	40.05	BEFM-025-1500K	44.15
2.5 mm	.0984	.0984	3 mm	20 mm	2.4 mm	2	3 mm	50 mm	BEFM-025-2000	50.00	BEFM-025-2000K	54.10
2.5 mm	.0984	.0984	3 mm	25 mm	2.4 mm	2	3 mm	50 mm	BEFM-025-2500	55.50	BEFM-025-2500K	59.60
2.5 mm	.0984	.0984	3 mm	30 mm	2.4 mm	2	3 mm	60 mm	BEFM-025-3000	61.00	BEFM-025-3000K	65.10
3 mm	.1181	.1181	3 mm	10 mm	2.9 mm	2	6 mm	57 mm	BEFM-030-1000	43.15	BEFM-030-1000K	48.20
3 mm	.1181	.1181	3 mm	15 mm	2.9 mm	2	6 mm	57 mm	BEFM-030-1500	49.40		
3 mm	.1181	.1181	3 mm	25 mm	2.9 mm	2	6 mm	57 mm	BEFM-030-2500	56.50		
3 mm	.1181	.1181	3 mm	30 mm	2.9 mm	2	6 mm	57 mm	BEFM-030-3000	62.00	BEFM-030-3000K	67.05
.1250	.1250	.1250	.125	.375	.121	2	.1875	2.0	BEF-125-375	36.50	BEF-125-375K	41.10
.1250	.1250	.1250	.125	.750	.121	2	.1875	2.0	BEF-125-750	41.50	BEF-125-750K	46.10
.1250	.1250	.1250	.125	1.000	.121	2	.1875	2.0	BEF-125-1000	43.75	BEF-125-1000K	48.65
.1250	.1250	.1250	.125	1.500	.121	2	.1875	3.0	BEF-125-1500	46.95	BEF-125-1500K	52.85
4 mm	.1575	.1575	5 mm	15 mm	3.9 mm	2	6 mm	57 mm	BEFM-040-1500	49.40	BEFM-040-1500K	54.45
4 mm	.1575	.1575	5 mm	25 mm	3.9 mm	2	6 mm	57 mm	BEFM-040-2500	56.50	BEFM-040-2500K	61.55
4 mm	.1575	.1575	5 mm	30 mm	3.9 mm	2	6 mm	57 mm	BEFM-040-3000	62.00	BEFM-040-3000K	67.05
.1875	.1875	.1875	.200	.500	.183	2	.2500	2.5	BEF-187-500	34.75		
.1875	.1875	.1875	.200	.750	.183	2	.2500	2.5	BEF-187-750	40.95		
.1875	.1875	.1875	.200	1.000	.183	2	.2500	2.5	BEF-187-1000	47.95	BEF-187-1000K	55.15
.1875	.1875	.1875	.200	1.500	.183	2	.2500	3.0	BEF-187-1500	54.95	BEF-187-1500K	62.15
5 mm	.1969	.1969	6 mm	15 mm	4.9 mm	2	6 mm	57 mm	BEFM-050-1500	49.40	BEFM-050-1500K	54.45
5 mm	.1969	.1969	6 mm	25 mm	4.9 mm	2	6 mm	57 mm	BEFM-050-2500	56.50	BEFM-050-2500K	61.55
5 mm	.1969	.1969	6 mm	30 mm	4.9 mm	2	6 mm	57 mm	BEFM-050-3000	62.00	BEFM-050-3000K	67.05
D1 +.0000" -.0010"	decimal equiv.	L2	L3	D3	D2 (h6)	L1	Tool #	Price	Tool #	Price		
.2500	.2500	.250	.500	.246	2	.2500	2.5	BEF-250-500	34.75	BEF-250-500K	41.95	
.2500	.2500	.250	.750	.246	2	.2500	2.5	BEF-250-750	40.95	BEF-250-750K	48.15	
.2500	.2500	.250	1.000	.246	2	.2500	2.5	BEF-250-1000	47.95	BEF-250-1000K	55.15	
.2500	.2500	.250	1.500	.246	2	.2500	3.0	BEF-250-1500	54.95	BEF-250-1500K	62.15	

\*.0005" / .013 mm max TIR

# End Mills For Steels & High Temperature Alloys

MEF / MEFM

Corner Radius – 2 & 3 Flute – Stub Flute

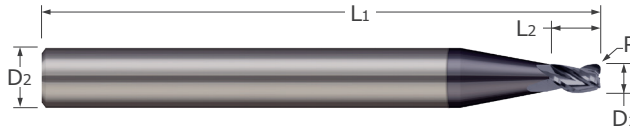

- Designed for high performance in titanium alloys, inconel, nickel alloys, and other high-temperature materials with outstanding performance in difficult-to-machine steels, stainless steels, and tool steels
- Stub flutes for maximum rigidity
- Corner radius profile ■ 20° helix ■ Center cutting
- nACRo® coating option for added heat resistance in difficult to machine materials
- Solid carbide ■ CNC ground in the USA

Steels & High Temp. Alloys

Cutter Diameter*			Length of Cut	Corner Radius	Flutes	Shank Diameter	Overall Length	Uncoated		nACRo® Coated	
D1 + .0000" -.0005"	+ .000 mm -.013 mm	decimal equiv.	L2 +.38 mm -.00 mm	R +.0000" -.0005" +.000 mm -.013 mm	D2 (h6)	L1	Tool #	Price	Tool #	Price	
											.0150
.0150	.0150	.0150	.023	.002	3	.1250	1.5	MEF-015-023-3-002	39.25	MEF-015-023-3-002K	43.35
0.5 mm	.0197	.0197	0.7 mm	0.05 mm	2	3 mm	38 mm	MEFM-005-070-05	27.75	MEFM-005-070-05K	31.85
.0200	.0200	.0200	.030	.002	2	.1250	1.5	MEF-020-030-002	27.75	MEF-020-030-002K	31.85
.0200	.0200	.0200	.030	.002	3	.1250	1.5	MEF-020-030-3-002	27.75	MEF-020-030-3-002K	31.85
.0250	.0250	.0250	.038	.003	2	.1250	1.5	MEF-025-038-003	27.75	MEF-025-038-003K	31.85
.0250	.0250	.0250	.038	.003	3	.1250	1.5	MEF-025-038-3-003	27.75	MEF-025-038-3-003K	31.85
.0300	.0300	.0300	.045	.005	2	.1250	1.5	MEF-030-045-005	25.50	MEF-030-045-005K	29.60
.0300	.0300	.0300	.045	.005	3	.1250	1.5	MEF-030-045-3-005	25.50	MEF-030-045-3-005K	29.60
.0300	.0300	.0300	.045	.010	2	.1250	1.5	MEF-030-045-010	25.50	MEF-030-045-010K	29.60
.0300	.0300	.0300	.045	.010	3	.1250	1.5	MEF-030-045-3-010	25.50	MEF-030-045-3-010K	29.60
.0313	.0313	.0313	.047	.005	2	.1250	1.5	MEF-031-047-005	25.50	MEF-031-047-005K	29.60
.0313	.0313	.0313	.047	.005	3	.1250	1.5	MEF-031-047-3-005	25.50	MEF-031-047-3-005K	29.60
.0313	.0313	.0313	.047	.010	2	.1250	1.5			MEF-031-047-010K	29.60
.0313	.0313	.0313	.047	.010	3	.1250	1.5	MEF-031-047-3-010	25.50	MEF-031-047-3-010K	29.60
0.8 mm	.0315	.0315	1.2 mm	0.05 mm	2	3 mm	38 mm	MEFM-008-120-05	25.50	MEFM-008-120-05K	29.60
.0350	.0350	.0350	.053	.005	2	.1250	1.5	MEF-035-053-005	25.50	MEF-035-053-005K	29.60
.0350	.0350	.0350	.053	.005	3	.1250	1.5	MEF-035-053-3-005	25.50	MEF-035-053-3-005K	29.60
.0350	.0350	.0350	.053	.010	2	.1250	1.5	MEF-035-053-010	25.50	MEF-035-053-010K	29.60
.0350	.0350	.0350	.053	.010	3	.1250	1.5	MEF-035-053-3-010	25.50	MEF-035-053-3-010K	29.60
1 mm	.0394	.0394	1.5 mm	0.1 mm	2	3 mm	38 mm	MEFM-010-150-10	25.50	MEFM-010-150-10K	29.60
1 mm	.0394	.0394	1.5 mm	0.2 mm	2	3 mm	38 mm	MEFM-010-150-20	25.50	MEFM-010-150-20K	29.60
.0400	.0400	.0400	.060	.005	2	.1250	1.5	MEF-040-060-005	25.50	MEF-040-060-005K	29.60
.0400	.0400	.0400	.060	.005	3	.1250	1.5	MEF-040-060-3-005	25.50	MEF-040-060-3-005K	29.60
.0400	.0400	.0400	.060	.010	2	.1250	1.5	MEF-040-060-010	25.50	MEF-040-060-010K	29.60
.0400	.0400	.0400	.060	.010	3	.1250	1.5	MEF-040-060-3-010	25.50	MEF-040-060-3-010K	29.60
.0450	.0450	.0450	.068	.005	2	.1250	1.5	MEF-045-068-005	25.50	MEF-045-068-005K	29.60
.0450	.0450	.0450	.068	.005	3	.1250	1.5	MEF-045-068-3-005	25.50	MEF-045-068-3-005K	29.60
.0450	.0450	.0450	.068	.010	2	.1250	1.5	MEF-045-068-010	25.50	MEF-045-068-010K	29.60
.0450	.0450	.0450	.068	.010	3	.1250	1.5	MEF-045-068-3-010	25.50	MEF-045-068-3-010K	29.60

\*.0005" / .013 mm max TIR

Continued on next page

MEF / MEFM

End Mills For Steels & High Temperature Alloys

Corner Radius – 2 & 3 Flute – Stub Flute (cont.)

Continued from previous page

Cutter Diameter*			Length of Cut	Corner Radius	Flutes	Shank Diameter	Overall Length	Uncoated		nACRo® Coated	
D1 +.0000" -.0005"	+.000 mm -.013 mm	decimal equiv.	L2 +.015" -.000" +.38 mm -.00 mm	R +.0000" -.0005" +.000 mm -.013 mm		D2 (h6)	L1	Tool #	Price	Tool #	Price
.0469		.0469	.071	.005	2	.1250	1.5	MEF-047-071-005	25.50	MEF-047-071-005K	29.60
.0469		.0469	.071	.005	3	.1250	1.5	MEF-047-071-3-005	25.50	MEF-047-071-3-005K	29.60
.0469		.0469	.071	.010	2	.1250	1.5	MEF-047-071-010	25.50	MEF-047-071-010K	29.60
.0469		.0469	.071	.010	3	.1250	1.5	MEF-047-071-3-010	25.50	MEF-047-071-3-010K	29.60
	1.2 mm	.0472	1.8 mm	0.1 mm	2	3 mm	38 mm	MEFM-012-180-10	25.50	MEFM-012-180-10K	29.60
	1.2 mm	.0472	1.8 mm	0.2 mm	2	3 mm	38 mm	MEFM-012-180-20	25.50	MEFM-012-180-20K	29.60
.0500		.0500	.075	.005	2	.1250	1.5	MEF-050-075-005	25.50	MEF-050-075-005K	29.60
.0500		.0500	.075	.005	3	.1250	1.5	MEF-050-075-3-005	25.50	MEF-050-075-3-005K	29.60
.0500		.0500	.075	.010	2	.1250	1.5	MEF-050-075-010	25.50	MEF-050-075-010K	29.60
.0500		.0500	.075	.010	3	.1250	1.5	MEF-050-075-3-010	25.50	MEF-050-075-3-010K	29.60
	1.5 mm	.0591	2.2 mm	0.15 mm	2	3 mm	38 mm	MEFM-015-220-15	25.50		
	1.5 mm	.0591	2.2 mm	0.25 mm	2	3 mm	38 mm	MEFM-015-220-25	25.50	MEFM-015-220-25K	29.60
.0600		.0600	.090	.005	2	.1250	1.5	MEF-060-090-005	25.50	MEF-060-090-005K	29.60
.0600		.0600	.090	.005	3	.1250	1.5	MEF-060-090-3-005	25.50	MEF-060-090-3-005K	29.60
.0600		.0600	.090	.010	2	.1250	1.5	MEF-060-090-010	25.50		
.0600		.0600	.090	.010	3	.1250	1.5	MEF-060-090-3-010	25.50	MEF-060-090-3-010K	29.60
.0600		.0600	.090	.015	2	.1250	1.5	MEF-060-090-015	25.50	MEF-060-090-015K	29.60
.0600		.0600	.090	.015	3	.1250	1.5	MEF-060-090-3-015	25.50	MEF-060-090-3-015K	29.60
.0625		.0625	.093	.005	2	.1250	1.5	MEF-062-093-005	25.50	MEF-062-093-005K	29.60
.0625		.0625	.093	.005	3	.1250	1.5	MEF-062-093-3-005	25.50		
.0625		.0625	.093	.010	2	.1250	1.5	MEF-062-093-010	25.50	MEF-062-093-010K	29.60
.0625		.0625	.093	.010	3	.1250	1.5	MEF-062-093-3-010	25.50		
.0625		.0625	.093	.015	2	.1250	1.5	MEF-062-093-015	25.50	MEF-062-093-015K	29.60
.0625		.0625	.093	.015	3	.1250	1.5	MEF-062-093-3-015	25.50	MEF-062-093-3-015K	29.60
.0750		.0750	.113	.005	2	.1250	1.5	MEF-075-113-005	25.50	MEF-075-113-005K	29.60
.0750		.0750	.113	.005	3	.1250	1.5	MEF-075-113-3-005	25.50	MEF-075-113-3-005K	29.60
.0750		.0750	.113	.010	2	.1250	1.5	MEF-075-113-010	25.50	MEF-075-113-010K	29.60
.0750		.0750	.113	.010	3	.1250	1.5	MEF-075-113-3-010	25.50	MEF-075-113-3-010K	29.60
.0750		.0750	.113	.015	2	.1250	1.5	MEF-075-113-015	25.50	MEF-075-113-015K	29.60
.0750		.0750	.113	.015	3	.1250	1.5	MEF-075-113-3-015	25.50	MEF-075-113-3-015K	29.60
.0781		.0781	.117	.005	2	.1250	1.5	MEF-078-117-005	25.50	MEF-078-117-005K	29.60
.0781		.0781	.117	.005	3	.1250	1.5	MEF-078-117-3-005	25.50	MEF-078-117-3-005K	29.60
.0781		.0781	.117	.010	2	.1250	1.5	MEF-078-117-010	25.50	MEF-078-117-010K	29.60
.0781		.0781	.117	.015	2	.1250	1.5	MEF-078-117-015	25.50	MEF-078-117-015K	29.60
.0781		.0781	.117	.015	3	.1250	1.5	MEF-078-117-3-015	25.50	MEF-078-117-3-015K	29.60
	2 mm	.0787	2.5 mm	0.15 mm	2	3 mm	38 mm	MEFM-020-250-15	25.50	MEFM-020-250-15K	29.60
	2 mm	.0787	2.5 mm	0.25 mm	2	3 mm	38 mm	MEFM-020-250-25	25.50	MEFM-020-250-25K	29.60
.0900		.0900	.125	.005	2	.1250	1.5	MEF-090-125-005	25.50	MEF-090-125-005K	29.60
.0900		.0900	.125	.010	2	.1250	1.5	MEF-090-125-010	25.50	MEF-090-125-010K	29.60
.0900		.0900	.125	.015	2	.1250	1.5	MEF-090-125-015	25.50	MEF-090-125-015K	29.60
.0938		.0938	.125	.005	2	.1250	1.5	MEF-093-125-005	25.50	MEF-093-125-005K	29.60
.0938		.0938	.125	.010	2	.1250	1.5	MEF-093-125-010	25.50	MEF-093-125-010K	29.60
.0938		.0938	.125	.015	2	.1250	1.5	MEF-093-125-015	25.50	MEF-093-125-015K	29.60

\*.0005" / .013 mm max TIR

Continued on next page

Steels & High Temp. Alloys

# End Mills For Steels & High Temperature Alloys

MEF / MEFM

Corner Radius – 2 & 3 Flute – Stub Flute (cont.)

Continued from previous page

Cutter Diameter*			Length of Cut	Corner Radius	Flutes	Shank Diameter	Overall Length	Uncoated		nACRo® Coated	
D1 +.0000" -.0005"	+ .000 mm -.013 mm	decimal equiv.	L2 +.015" -.000" +.38 mm -.00 mm	R +.0000" -.0005" +.000 mm -.013 mm		D2 (h6)	L1	Tool #	Price	Tool #	Price
2.5 mm	.0984		3 mm	0.15 mm	2	3 mm	38 mm			MEFM-025-300-15K	29.60
3 mm	.1181		3 mm	0.15 mm	2	6 mm	57 mm			MEFM-030-300-15K	44.10
3 mm	.1181		3 mm	0.25 mm	2	6 mm	57 mm	MEFM-030-300-25	36.90	MEFM-030-300-25K	44.10
.1250	.1250		.125	.005	2	.1875	2.0	MEF-125-125-005	27.50	MEF-125-125-005K	32.10
.1250	.1250		.125	.010	2	.1875	2.0	MEF-125-125-010	27.50	MEF-125-125-010K	32.10
4 mm	.1575		5 mm	0.25 mm	2	6 mm	57 mm	MEFM-040-500-25	36.90	MEFM-040-500-25K	44.10
5 mm	.1969		6 mm	0.25 mm	2	6 mm	57 mm	MEFM-050-600-25	36.90	MEFM-050-600-25K	44.10
D1 +.0000" -.0010"		decimal equiv.	L2 +.015" -.000"	R +.0000" -.0005"		D2 (h6)	L1	Tool #	Price	Tool #	Price
.2500		.2500	.250	.005	2	.2500	2.5	MEF-250-250-005	36.90	MEF-250-250-005K	44.10
.2500		.2500	.250	.010	2	.2500	2.5	MEF-250-250-010	36.90	MEF-250-250-010K	44.10
.2500		.2500	.250	.015	2	.2500	2.5	MEF-250-250-015	36.90	MEF-250-250-015K	44.10

\*.0005" / .013 mm max TIR

Steels & High Temp. Alloys

MEF / MEFM

End Mills For Steels & High Temperature Alloys  
 Corner Radius – 2 & 3 Flute – Long Reach, Stub Flute

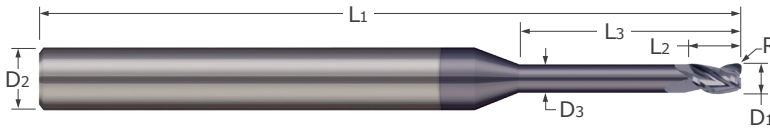

- Designed for high performance in titanium alloys, inconel, nickel alloys, and other high-temperature materials with outstanding performance in difficult-to-machine steels, stainless steels, and tool steels
- Long reach for deep pocket milling
- Stub flutes for maximum rigidity
- Reduced neck diameter to avoid heeling
- Corner radius profile ■ 20° helix ■ Center cutting
- nACRo® coating option for added heat resistance in difficult to machine materials
- Solid carbide ■ CNC ground in the USA

Cutter Diameter*		Length of Cut	Corner Radius	Overall Reach	Neck Dia.	Flutes	Shank Dia.	Overall Length	Uncoated		nACRo® Coated	
D1	D2	L2	R	L3	D3		D2 (h6)	L1	Tool #	Price	Tool #	Price
+ .0000" / + .000mm - .0005" / - .013mm		+ .015" / - .000" + .38mm / - .00mm	+ .0000" / - .0005" + .000mm / - .013mm	+ .010" / - .010" + .25mm / - .00mm								
.0150	.0150	.023	.002	.100	.014	2	.1250	1.5	MEF-015-100-002	44.25	MEF-015-100-002K	48.35
.0150	.0150	.023	.002	.100	.014	3	.1250	1.5			MEF-015-100-3-002K	48.35
.0150	.0150	.023	.002	.200	.014	2	.1250	1.5	MEF-015-200-002	45.25	MEF-015-200-002K	49.35
.0150	.0150	.023	.002	.200	.014	3	.1250	1.5	MEF-015-200-3-002	45.25	MEF-015-200-3-002K	49.35
0.5 mm	.0197	0.7 mm	0.05 mm	6 mm	0.45 mm	2	3 mm	38 mm	MEFM-005-600-05	34.50	MEFM-005-600-05K	38.60
.0200	.0200	.030	.002	.150	.019	2	.1250	1.5	MEF-020-150-002	32.75	MEF-020-150-002K	36.85
.0200	.0200	.030	.002	.250	.019	2	.1250	1.5	MEF-020-250-002	33.75	MEF-020-250-002K	37.85
.0200	.0200	.030	.002	.250	.019	3	.1250	1.5	MEF-020-250-3-002	33.75	MEF-020-250-3-002K	37.85
.0200	.0200	.020	.002	.150	.019	3	.1250	1.5	MEF-020-150-3-002	32.75	MEF-020-150-3-002K	36.85
0.6 mm	.0236	0.9 mm	0.05 mm	3 mm	0.55 mm	2	3 mm	38 mm	MEFM-006-300-05	32.75	MEFM-006-300-05K	36.85
0.6 mm	.0236	0.9 mm	0.05 mm	5 mm	0.55 mm	2	3 mm	38 mm	MEFM-006-500-05	33.75	MEFM-006-500-05K	37.85
0.6 mm	.0236	0.9 mm	0.05 mm	6 mm	0.55 mm	2	3 mm	38 mm	MEFM-006-600-05	36.75	MEFM-006-600-05K	40.85
.0250	.0250	.038	.003	.150	.024	2	.1250	1.5	MEF-025-150-003	32.75	MEF-025-150-003K	36.85
.0250	.0250	.038	.003	.150	.024	3	.1250	1.5	MEF-025-150-3-003	32.75	MEF-025-150-3-003K	36.85
.0250	.0250	.038	.003	.250	.024	2	.1250	1.5	MEF-025-250-003	33.75	MEF-025-250-003K	37.85
.0250	.0250	.038	.003	.250	.024	3	.1250	1.5	MEF-025-250-3-003	33.75	MEF-025-250-3-003K	37.85
.0300	.0300	.045	.005	.100	.028	2	.1250	1.5	MEF-030-100-005	30.50	MEF-030-100-005K	34.60
.0300	.0300	.045	.005	.100	.028	3	.1250	1.5			MEF-030-100-3-005K	34.60
.0300	.0300	.045	.005	.200	.028	2	.1250	1.5	MEF-030-200-005	31.50	MEF-030-200-005K	35.60
.0300	.0300	.045	.005	.200	.028	3	.1250	1.5	MEF-030-200-3-005	31.50	MEF-030-200-3-005K	35.60
.0300	.0300	.045	.005	.375	.028	2	.1250	1.5	MEF-030-375-005	34.50	MEF-030-375-005K	38.60
.0300	.0300	.045	.005	.375	.028	3	.1250	1.5	MEF-030-375-3-005	34.50	MEF-030-375-3-005K	38.60
.0300	.0300	.045	.010	.100	.028	2	.1250	1.5	MEF-030-100-010	30.50	MEF-030-100-010K	34.60
.0300	.0300	.045	.010	.100	.028	3	.1250	1.5	MEF-030-100-3-010	30.50	MEF-030-100-3-010K	34.60
.0300	.0300	.045	.010	.200	.028	2	.1250	1.5	MEF-030-200-010	31.50	MEF-030-200-010K	35.60
.0300	.0300	.045	.010	.200	.028	3	.1250	1.5	MEF-030-200-3-010	31.50	MEF-030-200-3-010K	35.60
.0300	.0300	.045	.010	.375	.028	2	.1250	1.5	MEF-030-375-010	34.50	MEF-030-375-010K	38.60
.0300	.0300	.045	.010	.375	.028	3	.1250	1.5	MEF-030-375-3-010	34.50	MEF-030-375-3-010K	38.60

\*.0005" / .013 mm max TIR

Continued on next page

# End Mills For Steels & High Temperature Alloys

## Corner Radius – 2 & 3 Flute – Long Reach, Stub Flute (cont.)

MEF / MEFM

Steels & High Temp. Alloys

Continued from previous page

Cutter Diameter*		Length of Cut	Corner Radius	Overall Reach	Neck Dia.	Flutes	Shank Dia.	Overall Length	Uncoated		nACRo® Coated	
D1 +.0000"/+.000mm -.0005"/-.013mm		L2 +.015" -.000" +.38mm -.00mm	R +.0000" -.0005" +.000mm -.013mm	L3 +.010" -.010" +.25mm -.00mm	D3		D2 (h6)	L1	Tool #	Price	Tool #	Price
.0313	.0313	.047	.005	.100	.029	2	.1250	1.5	MEF-031-100-005	30.50	MEF-031-100-005K	34.60
.0313	.0313	.047	.005	.100	.029	3	.1250	1.5	MEF-031-100-3-005	30.50	MEF-031-100-3-005K	34.60
.0313	.0313	.047	.005	.200	.029	2	.1250	1.5	MEF-031-200-005	31.50	MEF-031-200-005K	35.60
.0313	.0313	.047	.005	.200	.029	3	.1250	1.5	MEF-031-200-3-005	31.50	MEF-031-200-3-005K	35.60
.0313	.0313	.047	.005	.375	.029	2	.1250	1.5	MEF-031-375-005	34.50	MEF-031-375-005K	38.60
.0313	.0313	.047	.005	.375	.029	3	.1250	1.5	MEF-031-375-3-005	34.50	MEF-031-375-3-005K	38.60
.0313	.0313	.047	.010	.100	.029	2	.1250	1.5	MEF-031-100-010	30.50	MEF-031-100-010K	34.60
.0313	.0313	.047	.010	.100	.029	3	.1250	1.5	MEF-031-100-3-010	30.50	MEF-031-100-3-010K	34.60
.0313	.0313	.047	.010	.200	.029	2	.1250	1.5	MEF-031-200-010	31.50	MEF-031-200-010K	35.60
.0313	.0313	.047	.010	.200	.029	3	.1250	1.5	MEF-031-200-3-010	31.50	MEF-031-200-3-010K	35.60
.0313	.0313	.047	.010	.375	.029	2	.1250	1.5	MEF-031-375-010	34.50	MEF-031-375-010K	38.60
.0313	.0313	.047	.010	.375	.029	3	.1250	1.5	MEF-031-375-3-010	34.50	MEF-031-375-3-010K	38.60
0.8 mm	.0315	1.2 mm	0.05 mm	4 mm	0.75 mm	2	3 mm	38 mm			MEFM-008-400-05K	34.60
0.8 mm	.0315	1.2 mm	0.05 mm	7 mm	0.75 mm	2	3 mm	38 mm	MEFM-008-700-05	34.00	MEFM-008-700-05K	38.10
0.8 mm	.0315	1.2 mm	0.05 mm	9 mm	0.75 mm	2	3 mm	38 mm	MEFM-008-900-05	37.95	MEFM-008-900-05K	42.05
.0350	.0350	.053	.005	.150	.033	2	.1250	1.5	MEF-035-150-005	30.50	MEF-035-150-005K	34.60
.0350	.0350	.053	.005	.150	.033	3	.1250	1.5	MEF-035-150-3-005	30.50	MEF-035-150-3-005K	34.60
.0350	.0350	.053	.005	.250	.033	2	.1250	1.5	MEF-035-250-005	31.50	MEF-035-250-005K	35.60
.0350	.0350	.053	.005	.250	.033	3	.1250	1.5	MEF-035-250-3-005	31.50	MEF-035-250-3-005K	35.60
.0350	.0350	.053	.005	.400	.033	2	.1250	1.5	MEF-035-400-005	34.50	MEF-035-400-005K	38.60
.0350	.0350	.053	.005	.400	.033	3	.1250	1.5	MEF-035-400-3-005	34.50	MEF-035-400-3-005K	38.60
.0350	.0350	.053	.010	.150	.033	2	.1250	1.5	MEF-035-150-010	30.50	MEF-035-150-010K	34.60
.0350	.0350	.053	.010	.150	.033	3	.1250	1.5	MEF-035-150-3-010	30.50	MEF-035-150-3-010K	34.60
.0350	.0350	.053	.010	.250	.033	2	.1250	1.5	MEF-035-250-010	31.50	MEF-035-250-010K	35.60
.0350	.0350	.053	.010	.250	.033	3	.1250	1.5	MEF-035-250-3-010	31.50	MEF-035-250-3-010K	35.60
.0350	.0350	.053	.010	.400	.033	2	.1250	1.5	MEF-035-400-010	34.50	MEF-035-400-010K	38.60
.0350	.0350	.053	.010	.400	.033	3	.1250	1.5	MEF-035-400-3-010	34.50	MEF-035-400-3-010K	38.60
1 mm	.0394	1.5 mm	0.1 mm	4 mm	0.95 mm	2	3 mm	38 mm	MEFM-010-400-10	30.50	MEFM-010-400-10K	34.60
1 mm	.0394	1.5 mm	0.1 mm	7 mm	0.95 mm	2	3 mm	38 mm	MEFM-010-700-10	34.00	MEFM-010-700-10K	38.10
1 mm	.0394	1.5 mm	0.1 mm	9 mm	0.95 mm	2	3 mm	38 mm	MEFM-010-900-10	37.95	MEFM-010-900-10K	42.05
1 mm	.0394	1.5 mm	0.2 mm	4 mm	0.95 mm	2	3 mm	38 mm	MEFM-010-400-20	30.50	MEFM-010-400-20K	34.60
1 mm	.0394	1.5 mm	0.2 mm	7 mm	0.95 mm	2	3 mm	38 mm	MEFM-010-700-20	34.00	MEFM-010-700-20K	38.10
1 mm	.0394	1.5 mm	0.2 mm	9 mm	0.95 mm	2	3 mm	38 mm	MEFM-010-900-20	37.92	MEFM-010-900-20K	41.05
.0400	.0400	.060	.005	.150	.038	2	.1250	1.5	MEF-040-150-005	30.50	MEF-040-150-005K	34.60
.0400	.0400	.060	.005	.150	.038	3	.1250	1.5	MEF-040-150-3-005	30.50		
.0400	.0400	.060	.005	.250	.038	2	.1250	1.5	MEF-040-250-005	31.50	MEF-040-250-005K	35.60
.0400	.0400	.060	.005	.250	.038	3	.1250	1.5	MEF-040-250-3-005	31.50	MEF-040-250-3-005K	35.60
.0400	.0400	.060	.005	.500	.038	2	.1250	1.5	MEF-040-500-005	36.50	MEF-040-500-005K	40.60
.0400	.0400	.060	.005	.500	.038	3	.1250	1.5	MEF-040-500-3-005	36.50	MEF-040-500-3-005K	40.60
.0400	.0400	.060	.010	.150	.038	2	.1250	1.5	MEF-040-150-010	30.50	MEF-040-150-010K	34.60
.0400	.0400	.060	.010	.150	.038	3	.1250	1.5	MEF-040-150-3-010	30.50	MEF-040-150-3-010K	34.60
.0400	.0400	.060	.010	.250	.038	2	.1250	1.5	MEF-040-250-010	31.50	MEF-040-250-010K	35.60
.0400	.0400	.060	.010	.250	.038	3	.1250	1.5	MEF-040-250-3-010	31.50	MEF-040-250-3-010K	35.60
.0400	.0400	.060	.010	.500	.038	2	.1250	1.5	MEF-040-500-010	36.50	MEF-040-500-010K	40.60
.0400	.0400	.060	.010	.500	.038	3	.1250	1.5	MEF-040-500-3-010	36.50	MEF-040-500-3-010K	40.60

\*.0005" / .013 mm max TIR

Continued on next page

MEF / MEFM

End Mills For Steels & High Temperature Alloys  
 Corner Radius – 2 & 3 Flute – Long Reach, Stub Flute (cont.)

Continued from previous page

Cutter Diameter*		Length of Cut	Corner Radius	Overall Reach	Neck Dia.	Flutes	Shank Dia.	Overall Length	Uncoated		nACRo® Coated	
D1 +.0000"+.000mm -.0005"-.013mm		L2 +.015" -.000" +.38mm -.00mm	R +.0000" -.0005" +.000mm -.013mm	L3 +.010" -.010" +.25mm -.00mm	D3		D2 (h6)	L1	Tool #	Price	Tool #	Price
.0450	.0450	.068	.005	.150	.043	2	.1250	1.5	MEF-045-150-005	30.50	MEF-045-150-005K	34.60
.0450	.0450	.068	.005	.150	.043	3	.1250	1.5	MEF-045-150-3-005	30.50	MEF-045-150-3-005K	34.60
.0450	.0450	.068	.005	.250	.043	2	.1250	1.5	MEF-045-250-005	31.50	MEF-045-250-005K	35.60
.0450	.0450	.068	.005	.250	.043	3	.1250	1.5	MEF-045-250-3-005	31.50	MEF-045-250-3-005K	35.60
.0450	.0450	.068	.005	.500	.043	2	.1250	1.5	MEF-045-500-005	36.50	MEF-045-500-005K	40.60
.0450	.0450	.068	.005	.500	.043	3	.1250	1.5	MEF-045-500-3-005	36.50	MEF-045-500-3-005K	40.60
.0450	.0450	.068	.010	.150	.043	2	.1250	1.5	MEF-045-150-010	30.50	MEF-045-150-010K	34.60
.0450	.0450	.068	.010	.150	.043	3	.1250	1.5	MEF-045-150-3-010	30.50	MEF-045-150-3-010K	34.60
.0450	.0450	.068	.010	.250	.043	2	.1250	1.5	MEF-045-250-010	31.50	MEF-045-250-010K	35.60
.0450	.0450	.068	.010	.250	.043	3	.1250	1.5	MEF-045-250-3-010	31.50	MEF-045-250-3-010K	35.60
.0450	.0450	.068	.010	.500	.043	2	.1250	1.5	MEF-045-500-010	36.50	MEF-045-500-010K	40.60
.0450	.0450	.068	.010	.500	.043	3	.1250	1.5	MEF-045-500-3-010	36.50	MEF-045-500-3-010K	40.60
.0469	.0469	.071	.005	.150	.045	2	.1250	1.5	MEF-047-150-005	30.50	MEF-047-150-005K	34.60
.0469	.0469	.071	.005	.150	.045	3	.1250	1.5	MEF-047-150-3-005	30.50	MEF-047-150-3-005K	34.60
.0469	.0469	.071	.005	.250	.045	2	.1250	1.5	MEF-047-250-005	31.50	MEF-047-250-005K	35.60
.0469	.0469	.071	.005	.250	.045	3	.1250	1.5	MEF-047-250-3-005	31.50	MEF-047-250-3-005K	35.60
.0469	.0469	.071	.005	.500	.045	2	.1250	1.5	MEF-047-500-005	36.50		
.0469	.0469	.071	.005	.500	.045	3	.1250	1.5	MEF-047-500-3-005	36.50	MEF-047-500-3-005K	40.60
.0469	.0469	.071	.010	.150	.045	2	.1250	1.5	MEF-047-150-010	30.50	MEF-047-150-010K	34.60
.0469	.0469	.071	.010	.150	.045	3	.1250	1.5	MEF-047-150-3-010	30.50	MEF-047-150-3-010K	34.60
.0469	.0469	.071	.010	.250	.045	2	.1250	1.5	MEF-047-250-010	31.50	MEF-047-250-010K	35.60
.0469	.0469	.071	.010	.250	.045	3	.1250	1.5	MEF-047-250-3-010	31.50	MEF-047-250-3-010K	35.60
.0469	.0469	.071	.010	.500	.045	2	.1250	1.5	MEF-047-500-010	36.50	MEF-047-500-010K	40.60
.0469	.0469	.071	.010	.500	.045	3	.1250	1.5	MEF-047-500-3-010	36.50	MEF-047-500-3-010K	40.60
1.2 mm	.0472	1.8 mm	0.1 mm	6 mm	1.1 mm	2	3 mm	38 mm	MEFM-012-600-10	34.00	MEFM-012-600-10K	38.10
1.2 mm	.0472	1.8 mm	0.1 mm	10 mm	1.1 mm	2	3 mm	38 mm	MEFM-012-1000-10	37.95	MEFM-012-1000-10K	42.05
1.2 mm	.0472	1.8 mm	0.1 mm	12 mm	1.1 mm	2	3 mm	38 mm	MEFM-012-1200-10	41.25	MEFM-012-1200-10K	45.35
1.2 mm	.0472	1.8 mm	0.2 mm	6 mm	1.1 mm	2	3 mm	38 mm			MEFM-012-600-20K	38.10
1.2 mm	.0472	1.8 mm	0.2 mm	10 mm	1.1 mm	2	3 mm	38 mm	MEFM-012-1000-20	37.95	MEFM-012-1000-20K	42.05
1.2 mm	.0472	1.8 mm	0.2 mm	12 mm	1.1 mm	2	3 mm	38 mm	MEFM-012-1200-20	41.25	MEFM-012-1200-20K	45.35
.0500	.0500	.075	.005	.200	.048	2	.1250	1.5	MEF-050-200-005	30.50	MEF-050-200-005K	34.60
.0500	.0500	.075	.005	.200	.048	3	.1250	1.5	MEF-050-200-3-005	30.50	MEF-050-200-3-005K	34.60
.0500	.0500	.075	.005	.300	.048	2	.1250	1.5	MEF-050-300-005	32.50	MEF-050-300-005K	36.60
.0500	.0500	.075	.005	.300	.048	3	.1250	1.5	MEF-050-300-3-005	32.50	MEF-050-300-3-005K	36.60
.0500	.0500	.075	.005	.550	.048	2	.1250	1.5	MEF-050-550-005	36.50	MEF-050-550-005K	40.60
.0500	.0500	.075	.005	.550	.048	3	.1250	1.5	MEF-050-550-3-005	36.50	MEF-050-550-3-005K	40.60
.0500	.0500	.075	.010	.200	.048	2	.1250	1.5	MEF-050-200-010	30.50	MEF-050-200-010K	34.60
.0500	.0500	.075	.010	.200	.048	3	.1250	1.5	MEF-050-200-3-010	30.50	MEF-050-200-3-010K	34.60
.0500	.0500	.075	.010	.300	.048	2	.1250	1.5	MEF-050-300-010	32.50	MEF-050-300-010K	36.60
.0500	.0500	.075	.010	.300	.048	3	.1250	1.5	MEF-050-300-3-010	32.50	MEF-050-300-3-010K	36.60
.0500	.0500	.075	.010	.550	.048	2	.1250	1.5	MEF-050-550-010	36.50	MEF-050-550-010K	40.60
.0500	.0500	.075	.010	.550	.048	3	.1250	1.5	MEF-050-550-3-010	36.50	MEF-050-550-3-010K	40.60

Steels & High Temp. Alloys

\*.0005" / .013 mm max TIR

Continued on next page

# End Mills For Steels & High Temperature Alloys

## Corner Radius – 2 & 3 Flute – Long Reach, Stub Flute (cont.)

MEF / MEFM

Continued from previous page

Steels & High Temp. Alloys

Cutter Diameter*	Length of Cut	Corner Radius	Overall Reach	Neck Dia.	Flutes	Shank Dia.	Overall Length	Uncoated		nACRo® Coated	
								Tool #	Price	Tool #	Price
D1 +.0000"+.000mm -.0005"-.013mm	L2 +.015" -.000" +.38mm -.00mm	R +.0000" -.0005" +.000mm -.013mm	L3 +.010" -.010" +.25mm -.00mm	D3		D2 (h6)	L1				
1.5 mm .0591	2.2 mm	0.15 mm	6 mm	1.4 mm	2	3 mm	38 mm	MEFM-015-600-15	34.00		
1.5 mm .0591	2.2 mm	0.15 mm	10 mm	1.4 mm	2	3 mm	38 mm	MEFM-015-1000-15	37.95	MEFM-015-1000-15K	42.05
1.5 mm .0591	2.2 mm	0.15 mm	12 mm	1.4 mm	2	3 mm	38 mm	MEFM-015-1200-15	41.25	MEFM-015-1200-15K	45.35
1.5 mm .0591	2.2 mm	0.15 mm	15 mm	1.4 mm	2	3 mm	38 mm	MEFM-015-1500-15	43.50	MEFM-015-1500-15K	47.60
1.5 mm .0591	2.2 mm	0.15 mm	20 mm	1.4 mm	2	3 mm	50 mm	MEFM-015-2000-15	53.50	MEFM-015-2000-15K	57.60
1.5 mm .0591	2.2 mm	0.25 mm	6 mm	1.4 mm	2	3 mm	38 mm	MEFM-015-600-25	34.00	MEFM-015-600-25K	38.10
1.5 mm .0591	2.2 mm	0.25 mm	10 mm	1.4 mm	2	3 mm	38 mm	MEFM-015-1000-25	37.95	MEFM-015-1000-25K	42.05
1.5 mm .0591	2.2 mm	0.25 mm	12 mm	1.4 mm	2	3 mm	38 mm	MEFM-015-1200-25	41.25	MEFM-015-1200-25K	45.35
1.5 mm .0591	2.2 mm	0.25 mm	15 mm	1.4 mm	2	3 mm	38 mm	MEFM-015-1500-25	43.50	MEFM-015-1500-25K	47.60
1.5 mm .0591	2.2 mm	0.25 mm	20 mm	1.4 mm	2	3 mm	50 mm	MEFM-015-2000-25	53.50	MEFM-015-2000-25K	57.60
.0600 .0600	.090	.005	.200	.056	2	.1250	1.5	MEF-060-200-005	30.50	MEF-060-200-005K	34.60
.0600 .0600	.090	.005	.200	.056	3	.1250	1.5	MEF-060-200-3-005	30.50	MEF-060-200-3-005K	34.60
.0600 .0600	.090	.005	.350	.056	2	.1250	1.5	MEF-060-350-005	32.50	MEF-060-350-005K	36.60
.0600 .0600	.090	.005	.350	.056	3	.1250	1.5	MEF-060-350-3-005	32.50	MEF-060-350-3-005K	36.60
.0600 .0600	.090	.005	.500	.056	2	.1250	1.5	MEF-060-500-005	36.50	MEF-060-500-005K	40.60
.0600 .0600	.090	.005	.500	.056	3	.1250	1.5	MEF-060-500-3-005	36.50	MEF-060-500-3-005K	40.60
.0600 .0600	.090	.005	.750	.056	2	.1250	2.0	MEF-060-750-005	41.50	MEF-060-750-005K	45.60
.0600 .0600	.090	.005	.750	.056	3	.1250	2.0	MEF-060-750-3-005	41.50	MEF-060-750-3-005K	45.60
.0600 .0600	.090	.010	.200	.056	2	.1250	1.5			MEF-060-200-010K	34.60
.0600 .0600	.090	.010	.200	.056	3	.1250	1.5	MEF-060-200-3-010	30.50	MEF-060-200-3-010K	34.60
.0600 .0600	.090	.010	.350	.056	2	.1250	1.5	MEF-060-350-010	32.50	MEF-060-350-010K	36.60
.0600 .0600	.090	.010	.350	.056	3	.1250	1.5	MEF-060-350-3-010	32.50	MEF-060-350-3-010K	36.60
.0600 .0600	.090	.010	.500	.056	2	.1250	1.5	MEF-060-500-010	36.50	MEF-060-500-010K	40.60
.0600 .0600	.090	.010	.500	.056	3	.1250	1.5	MEF-060-500-3-010	36.50	MEF-060-500-3-010K	40.60
.0600 .0600	.090	.010	.750	.056	2	.1250	2.0	MEF-060-750-010	41.50	MEF-060-750-010K	45.60
.0600 .0600	.090	.010	.750	.056	3	.1250	2.0	MEF-060-750-3-010	41.50	MEF-060-750-3-010K	45.60
.0600 .0600	.090	.015	.200	.056	2	.1250	1.5	MEF-060-200-015	30.50	MEF-060-200-015K	34.60
.0600 .0600	.090	.015	.200	.056	3	.1250	1.5	MEF-060-200-3-015	30.50	MEF-060-200-3-015K	34.60
.0600 .0600	.090	.015	.350	.056	2	.1250	1.5	MEF-060-350-015	32.50	MEF-060-350-015K	36.60
.0600 .0600	.090	.015	.350	.056	3	.1250	1.5	MEF-060-350-3-015	32.50	MEF-060-350-3-015K	36.60
.0600 .0600	.090	.015	.500	.056	2	.1250	1.5	MEF-060-500-015	36.50	MEF-060-500-015K	40.60
.0600 .0600	.090	.015	.500	.056	3	.1250	1.5	MEF-060-500-3-015	36.50	MEF-060-500-3-015K	40.60
.0600 .0600	.090	.015	.750	.056	2	.1250	2.0	MEF-060-750-015	41.50	MEF-060-750-015K	45.60
.0600 .0600	.090	.015	.750	.056	3	.1250	2.0	MEF-060-750-3-015	41.50	MEF-060-750-3-015K	45.60
.0625 .0625	.093	.005	.200	.058	2	.1250	1.5	MEF-062-200-005	30.50	MEF-062-200-005K	34.60
.0625 .0625	.093	.005	.200	.058	3	.1250	1.5	MEF-062-200-3-005	30.50	MEF-062-200-3-005K	34.60
.0625 .0625	.093	.005	.350	.058	2	.1250	1.5	MEF-062-350-005	32.50	MEF-062-350-005K	36.60
.0625 .0625	.093	.005	.350	.058	3	.1250	1.5	MEF-062-350-3-005	32.50	MEF-062-350-3-005K	36.60
.0625 .0625	.093	.005	.550	.058	2	.1250	1.5	MEF-062-550-005	36.50	MEF-062-550-005K	40.60
.0625 .0625	.093	.005	.550	.058	3	.1250	1.5	MEF-062-550-3-005	36.50	MEF-062-550-3-005K	40.60
.0625 .0625	.093	.005	.750	.058	2	.1250	2.0	MEF-062-750-005	41.50	MEF-062-750-005K	45.60
.0625 .0625	.093	.005	.750	.058	3	.1250	2.0	MEF-062-750-3-005	41.50	MEF-062-750-3-005K	45.60

\*.0005" / .013 mm max TIR

Continued on next page



MEF / MEFM

End Mills For Steels & High Temperature Alloys  
 Corner Radius – 2 & 3 Flute – Long Reach, Stub Flute (cont.)

Continued from previous page

Cutter Diameter*	Length of Cut	Corner Radius	Overall Reach	Neck Dia.	Flutes	Shank Dia.	Overall Length	Uncoated		nACRo® Coated	
								Tool #	Price	Tool #	Price
D1 +.0000"/+.000mm -.0005"/-.013mm	L2	R +.0000"/-.0005" +.0000mm/-.013mm	L3 +.010"/-.010" +.25mm/-.00mm	D3		D2 (h6)	L1				
.0625 .0625	.093	.010	.200	.058	2	.1250	1.5	MEF-062-200-010	30.50	MEF-062-200-010K	34.60
.0625 .0625	.093	.010	.200	.058	3	.1250	1.5	MEF-062-200-3-010	30.50	MEF-062-200-3-010K	34.60
.0625 .0625	.093	.010	.350	.058	2	.1250	1.5	MEF-062-350-010	32.50	MEF-062-350-010K	36.60
.0625 .0625	.093	.010	.350	.058	3	.1250	1.5	MEF-062-350-3-010	32.50	MEF-062-350-3-010K	36.60
.0625 .0625	.093	.010	.550	.058	2	.1250	1.5	MEF-062-550-010	36.50	MEF-062-550-010K	40.60
.0625 .0625	.093	.010	.550	.058	3	.1250	1.5	MEF-062-550-3-010	36.50	MEF-062-550-3-010K	40.60
.0625 .0625	.093	.010	.750	.058	2	.1250	2.0	MEF-062-750-010	41.50	MEF-062-750-010K	45.60
.0625 .0625	.093	.010	.750	.058	3	.1250	2.0	MEF-062-750-3-010	41.50	MEF-062-750-3-010K	45.60
.0625 .0625	.093	.015	.200	.058	2	.1250	1.5	MEF-062-200-015	30.50	MEF-062-200-015K	34.60
.0625 .0625	.093	.015	.200	.058	3	.1250	1.5	MEF-062-200-3-015	30.50	MEF-062-200-3-015K	34.60
.0625 .0625	.093	.015	.350	.058	2	.1250	1.5	MEF-062-350-015	32.00	MEF-062-350-015K	36.10
.0625 .0625	.093	.015	.350	.058	3	.1250	1.5	MEF-062-350-3-015	32.00	MEF-062-350-3-015K	36.10
.0625 .0625	.093	.015	.550	.058	2	.1250	1.5	MEF-062-550-015	36.50	MEF-062-550-015K	40.60
.0625 .0625	.093	.015	.550	.058	3	.1250	1.5	MEF-062-550-3-015	36.50	MEF-062-550-3-015K	40.60
.0625 .0625	.093	.015	.750	.058	2	.1250	2.0	MEF-062-750-015	41.50	MEF-062-750-015K	45.60
.0625 .0625	.093	.015	.750	.058	3	.1250	2.0	MEF-062-750-3-015	41.50	MEF-062-750-3-015K	45.60
.0750 .0750	.113	.005	.250	.071	2	.1250	1.5	MEF-075-250-005	30.50	MEF-075-250-005K	34.60
.0750 .0750	.113	.005	.250	.071	3	.1250	1.5	MEF-075-250-3-005	30.50	MEF-075-250-3-005K	34.60
.0750 .0750	.113	.005	.400	.071	2	.1250	1.5	MEF-075-400-005	32.50	MEF-075-400-005K	36.60
.0750 .0750	.113	.005	.400	.071	3	.1250	1.5	MEF-075-400-3-005	32.50	MEF-075-400-3-005K	36.60
.0750 .0750	.113	.005	.600	.071	2	.1250	2.0	MEF-075-600-005	36.50	MEF-075-600-005K	40.60
.0750 .0750	.113	.005	.600	.071	3	.1250	2.0	MEF-075-600-3-005	36.50	MEF-075-600-3-005K	40.60
.0750 .0750	.113	.005	.900	.071	2	.1250	2.0	MEF-075-900-005	43.75	MEF-075-900-005K	47.85
.0750 .0750	.113	.005	.900	.071	3	.1250	2.0	MEF-075-900-3-005	43.75	MEF-075-900-3-005K	47.85
.0750 .0750	.113	.010	.250	.071	2	.1250	1.5	MEF-075-250-010	30.50	MEF-075-250-010K	34.60
.0750 .0750	.113	.010	.250	.071	3	.1250	1.5	MEF-075-250-3-010	30.50	MEF-075-250-3-010K	34.60
.0750 .0750	.113	.010	.400	.071	2	.1250	1.5	MEF-075-400-010	32.50	MEF-075-400-010K	36.60
.0750 .0750	.113	.010	.400	.071	3	.1250	1.5	MEF-075-400-3-010	32.50	MEF-075-400-3-010K	36.60
.0750 .0750	.113	.010	.600	.071	2	.1250	2.0	MEF-075-600-010	36.50	MEF-075-600-010K	40.60
.0750 .0750	.113	.010	.600	.071	3	.1250	2.0	MEF-075-600-3-010	36.50	MEF-075-600-3-010K	40.60
.0750 .0750	.113	.010	.900	.071	2	.1250	2.0	MEF-075-900-010	43.75	MEF-075-900-010K	47.85
.0750 .0750	.113	.010	.900	.071	3	.1250	2.0	MEF-075-900-3-010	43.75	MEF-075-900-3-010K	47.85
.0750 .0750	.113	.015	.250	.071	2	.1250	1.5	MEF-075-250-015	30.50	MEF-075-250-015K	34.60
.0750 .0750	.113	.015	.250	.071	3	.1250	1.5	MEF-075-250-3-015	30.50	MEF-075-250-3-015K	34.60
.0750 .0750	.113	.015	.400	.071	2	.1250	1.5	MEF-075-400-015	32.50	MEF-075-400-015K	36.60
.0750 .0750	.113	.015	.400	.071	3	.1250	1.5	MEF-075-400-3-015	32.50	MEF-075-400-3-015K	36.60
.0750 .0750	.113	.015	.600	.071	2	.1250	2.0	MEF-075-600-015	36.50	MEF-075-600-015K	40.60
.0750 .0750	.113	.015	.600	.071	3	.1250	2.0	MEF-075-600-3-015	36.50	MEF-075-600-3-015K	40.60
.0750 .0750	.113	.015	.900	.071	2	.1250	2.0	MEF-075-900-015	43.75	MEF-075-900-015K	47.85
.0750 .0750	.113	.015	.900	.071	3	.1250	2.0	MEF-075-900-3-015	43.75	MEF-075-900-3-015K	47.85
.0781 .0781	.117	.005	.250	.074	2	.1250	1.5	MEF-078-250-005	30.50	MEF-078-250-005K	34.60
.0781 .0781	.117	.005	.250	.074	3	.1250	1.5	MEF-078-250-3-005	30.50	MEF-078-250-3-005K	34.60
.0781 .0781	.117	.005	.400	.074	2	.1250	1.5	MEF-078-400-005	32.50	MEF-078-400-005K	36.60
.0781 .0781	.117	.005	.400	.074	3	.1250	1.5	MEF-078-400-3-005	32.50	MEF-078-400-3-005K	36.60
.0781 .0781	.117	.005	.650	.074	2	.1250	2.0	MEF-078-650-005	36.50	MEF-078-650-005K	40.60

\*.0005" / .013 mm max TIR

Continued on next page

Steels & High Temp. Alloys

# End Mills For Steels & High Temperature Alloys

## Corner Radius – 2 & 3 Flute – Long Reach, Stub Flute (cont.)

MEF / MEFM

Continued from previous page

Steels & High Temp. Alloys

Cutter Diameter*	Length of Cut	Corner Radius	Overall Reach	Neck Dia.	Flutes	Shank Dia.	Overall Length	Uncoated		nACRo® Coated	
								Tool #	Price	Tool #	Price
D1 +.0000" +.000mm -.0005" -.013mm	L2 +.015" +.38mm -.000" -.00mm	R +.0000" +.000mm -.0005" -.013mm	L3 +.010" +.25mm -.010" -.00mm	D3	D2 (h6)	L1					
.0781 .0781 .117 .005 .650 .074 3 .1250 2.0								MEF-078-650-3-005	36.50	MEF-078-650-3-005K	40.60
.0781 .0781 .117 .005 .900 .074 2 .1250 2.0								MEF-078-900-005	43.75	MEF-078-900-005K	47.85
.0781 .0781 .117 .005 .900 .074 3 .1250 2.0								MEF-078-900-3-005	43.75	MEF-078-900-3-005K	47.85
.0781 .0781 .117 .010 .250 .074 2 .1250 1.5								MEF-078-250-010	30.50	MEF-078-250-010K	34.60
.0781 .0781 .117 .010 .250 .074 3 .1250 1.5								MEF-078-250-3-010	30.50	MEF-078-250-3-010K	34.60
.0781 .0781 .117 .010 .400 .074 2 .1250 1.5								MEF-078-400-010	32.50	MEF-078-400-010K	36.60
.0781 .0781 .117 .010 .400 .074 3 .1250 1.5								MEF-078-400-3-010	32.50	MEF-078-400-3-010K	36.60
.0781 .0781 .117 .010 .650 .074 2 .1250 2.0								MEF-078-650-010	36.50	MEF-078-650-010K	40.60
.0781 .0781 .117 .010 .650 .074 3 .1250 2.0								MEF-078-650-3-010	36.50	MEF-078-650-3-010K	40.60
.0781 .0781 .117 .010 .900 .074 2 .1250 2.0								MEF-078-900-010	43.75	MEF-078-900-010K	47.85
.0781 .0781 .117 .010 .900 .074 3 .1250 2.0								MEF-078-900-3-010	43.75	MEF-078-900-3-010K	47.85
.0781 .0781 .117 .015 .250 .074 2 .1250 1.5								MEF-078-250-015	30.50	MEF-078-250-015K	34.60
.0781 .0781 .117 .015 .250 .074 3 .1250 1.5								MEF-078-250-3-015	30.50	MEF-078-250-3-015K	34.60
.0781 .0781 .117 .015 .400 .074 2 .1250 1.5								MEF-078-400-015	32.50	MEF-078-400-015K	36.60
.0781 .0781 .117 .015 .400 .074 3 .1250 1.5								MEF-078-400-3-015	32.50	MEF-078-400-3-015K	36.60
.0781 .0781 .117 .015 .650 .074 2 .1250 2.0								MEF-078-650-015	36.50	MEF-078-650-015K	40.60
.0781 .0781 .117 .015 .650 .074 3 .1250 2.0								MEF-078-650-3-015	36.50	MEF-078-650-3-015K	40.60
.0781 .0781 .117 .015 .900 .074 2 .1250 2.0										MEF-078-900-015K	47.85
.0781 .0781 .117 .015 .900 .074 3 .1250 2.0								MEF-078-900-3-015	43.75	MEF-078-900-3-015K	47.85
2 mm .0787 2.5 mm 0.15 mm 7 mm 1.9 mm 2 3 mm 38 mm								MEFM-020-700-15	35.00	MEFM-020-700-15K	39.10
2 mm .0787 2.5 mm 0.15 mm 12 mm 1.9 mm 2 3 mm 38 mm								MEFM-020-1200-15	41.25	MEFM-020-1200-15K	45.35
2 mm .0787 2.5 mm 0.15 mm 16 mm 1.9 mm 2 3 mm 38 mm								MEFM-020-1600-15	43.50	MEFM-020-1600-15K	47.60
2 mm .0787 2.5 mm 0.15 mm 20 mm 1.9 mm 2 3 mm 50 mm										MEFM-020-2000-15K	57.60
2 mm .0787 2.5 mm 0.15 mm 25 mm 1.9 mm 2 3 mm 50 mm								MEFM-020-2500-15	59.00	MEFM-020-2500-15K	63.10
2 mm .0787 2.5 mm 0.25 mm 7 mm 1.9 mm 2 3 mm 38 mm								MEFM-020-700-25	35.00	MEFM-020-700-25K	39.10
2 mm .0787 2.5 mm 0.25 mm 12 mm 1.9 mm 2 3 mm 38 mm								MEFM-020-1200-25	41.25	MEFM-020-1200-25K	45.35
2 mm .0787 2.5 mm 0.25 mm 16 mm 1.9 mm 2 3 mm 38 mm								MEFM-020-1600-25	43.50	MEFM-020-1600-25K	47.60
2 mm .0787 2.5 mm 0.25 mm 20 mm 1.9 mm 2 3 mm 50 mm								MEFM-020-2000-25	53.50	MEFM-020-2000-25K	57.60
2 mm .0787 2.5 mm 0.25 mm 25 mm 1.9 mm 2 3 mm 50 mm								MEFM-020-2500-25	59.00	MEFM-020-2500-25K	63.10
.0900 .0900 .125 .005 .250 .086 2 .1250 1.5								MEF-090-250-005	30.50	MEF-090-250-005K	34.60
.0900 .0900 .125 .005 .400 .086 2 .1250 1.5								MEF-090-400-005	32.50	MEF-090-400-005K	36.60
.0900 .0900 .125 .005 .650 .086 2 .1250 2.0								MEF-090-650-005	36.50	MEF-090-650-005K	40.60
.0900 .0900 .125 .005 .900 .086 2 .1250 2.0								MEF-090-900-005	43.75	MEF-090-900-005K	47.85
.0900 .0900 .125 .010 .250 .086 2 .1250 1.5								MEF-090-250-010	30.50	MEF-090-250-010K	34.60
.0900 .0900 .125 .010 .400 .086 2 .1250 1.5								MEF-090-400-010	32.50	MEF-090-400-010K	36.60
.0900 .0900 .125 .010 .650 .086 2 .1250 2.0								MEF-090-650-010	36.50	MEF-090-650-010K	40.60
.0900 .0900 .125 .010 .900 .086 2 .1250 2.0								MEF-090-900-010	43.75	MEF-090-900-010K	47.85
.0900 .0900 .125 .015 .250 .086 2 .1250 1.5								MEF-090-250-015	30.50	MEF-090-250-015K	34.60
.0900 .0900 .125 .015 .400 .086 2 .1250 1.5								MEF-090-400-015	32.50	MEF-090-400-015K	36.60
.0900 .0900 .125 .015 .650 .086 2 .1250 2.0								MEF-090-650-015	36.50	MEF-090-650-015K	40.60
.0900 .0900 .125 .015 .900 .086 2 .1250 2.0								MEF-090-900-015	43.75	MEF-090-900-015K	47.85
.0938 .0938 .125 .005 .250 .089 2 .1250 1.5								MEF-093-250-005	30.50	MEF-093-250-005K	34.60
.0938 .0938 .125 .005 .500 .089 2 .1250 1.5								MEF-093-500-005	36.50	MEF-093-500-005K	40.60
.0938 .0938 .125 .005 .750 .089 2 .1250 2.0								MEF-093-750-005	41.50	MEF-093-750-005K	45.60
.0938 .0938 .125 .005 1.000 .089 2 .1250 2.0								MEF-093-1000-005	43.75	MEF-093-1000-005K	47.85

\*.0005" / .013 mm max TIR

Continued on next page

MEF / MEFM

End Mills For Steels & High Temperature Alloys  
 Corner Radius – 2 & 3 Flute – Long Reach, Stub Flute (cont.)

Continued from previous page

Cutter Diameter*	Length of Cut	Corner Radius	Overall Reach	Neck Dia.	Flutes	Shank Dia.	Overall Length	Uncoated		nAcRo® Coated	
								Tool #	Price	Tool #	Price
D1 +.0000" +.000mm -.0005" -.013mm	L2	R +.0000" +.000mm -.0005" -.013mm	L3 +.010" +.25mm -.010" -.00mm	D3		D2 (h6)	L1				
.0938 .0938	.125	.010	.250	.089	2	.1250	1.5	MEF-093-250-010	30.50	MEF-093-250-010K	34.60
.0938 .0938	.125	.010	.500	.089	2	.1250	1.5	MEF-093-500-010	36.50	MEF-093-500-010K	40.60
.0938 .0938	.125	.010	.750	.089	2	.1250	2.0	MEF-093-750-010	41.50	MEF-093-750-010K	45.60
.0938 .0938	.125	.010	1.000	.089	2	.1250	2.0	MEF-093-1000-010	43.75	MEF-093-1000-010K	47.85
.0938 .0938	.125	.015	.250	.089	2	.1250	1.5	MEF-093-250-015	30.50	MEF-093-250-015K	34.60
.0938 .0938	.125	.015	.500	.089	2	.1250	1.5	MEF-093-500-015	36.50	MEF-093-500-015K	40.60
.0938 .0938	.125	.015	.750	.089	2	.1250	2.0	MEF-093-750-015	41.50		
.0938 .0938	.125	.015	1.000	.089	2	.1250	2.0	MEF-093-1000-015	43.75	MEF-093-1000-015K	47.85
2.5 mm .0984	3 mm	0.15 mm	15 mm	2.4 mm	2	3 mm	38 mm	MEFM-025-1500-15	43.50	MEFM-025-1500-15K	47.60
2.5 mm .0984	3 mm	0.15 mm	20 mm	2.4 mm	2	3 mm	50 mm	MEFM-025-2000-15	53.50	MEFM-025-2000-15K	57.60
2.5 mm .0984	3 mm	0.15 mm	25 mm	2.4 mm	2	3 mm	50 mm	MEFM-025-2500-15	59.00	MEFM-025-2500-15K	63.10
2.5 mm .0984	3 mm	0.15 mm	30 mm	2.4 mm	2	3 mm	60 mm			MEFM-025-3000-15K	68.60
2.5 mm .0984	3 mm	0.25 mm	20 mm	2.4 mm	2	3 mm	50 mm	MEFM-025-2000-25	53.50	MEFM-025-2000-25K	57.60
2.5 mm .0984	3 mm	0.25 mm	25 mm	2.4 mm	2	3 mm	50 mm	MEFM-025-2500-25	59.00	MEFM-025-2500-25K	63.10
3 mm .1181	3 mm	0.15 mm	10 mm	2.9 mm	2	6 mm	57 mm			MEFM-030-1000-15K	50.35
3 mm .1181	3 mm	0.15 mm	15 mm	2.9 mm	2	6 mm	57 mm	MEFM-030-1500-15	49.40	MEFM-030-1500-15K	56.60
3 mm .1181	3 mm	0.15 mm	25 mm	2.9 mm	2	6 mm	57 mm			MEFM-030-2500-15K	63.70
3 mm .1181	3 mm	0.15 mm	30 mm	2.9 mm	2	6 mm	57 mm	MEFM-030-3000-15	62.00	MEFM-030-3000-15K	69.20
3 mm .1181	3 mm	0.25 mm	10 mm	2.9 mm	2	6 mm	57 mm	MEFM-030-1000-25	43.15	MEFM-030-1000-25K	50.35
3 mm .1181	3 mm	0.25 mm	15 mm	2.9 mm	2	6 mm	57 mm	MEFM-030-1500-25	49.40	MEFM-030-1500-25K	56.60
3 mm .1181	3 mm	0.25 mm	30 mm	2.9 mm	2	6 mm	57 mm	MEFM-030-3000-25	62.00		
.1250 .1250	.125	.005	.375	.121	2	.1875	2.0	MEF-125-375-005	32.50	MEF-125-375-005K	37.10
.1250 .1250	.125	.005	.750	.121	2	.1875	2.0	MEF-125-750-005	38.50	MEF-125-750-005K	43.10
.1250 .1250	.125	.005	1.000	.121	2	.1875	2.0	MEF-125-1000-005	43.50	MEF-125-1000-005K	48.10
.1250 .1250	.125	.005	1.500	.121	2	.1875	3.0	MEF-125-1500-005	46.95	MEF-125-1500-005K	52.85
.1250 .1250	.125	.010	.375	.121	2	.1875	2.0	MEF-125-375-010	32.50		
.1250 .1250	.125	.010	.750	.121	2	.1875	2.0	MEF-125-750-010	38.50	MEF-125-750-010K	43.10
.1250 .1250	.125	.010	1.000	.121	2	.1875	2.0	MEF-125-1000-010	43.50	MEF-125-1000-010K	48.10
.1250 .1250	.125	.010	1.500	.121	2	.1875	3.0	MEF-125-1500-010	46.95	MEF-125-1500-010K	52.85
.1250 .1250	.125	.015	.375	.121	2	.1875	2.0	MEF-125-375-015	32.50	MEF-125-375-015K	37.10
.1250 .1250	.125	.015	.750	.121	2	.1875	2.0	MEF-125-750-015	38.50	MEF-125-750-015K	43.10
.1250 .1250	.125	.015	1.000	.121	2	.1875	2.0	MEF-125-1000-015	43.50	MEF-125-1000-015K	48.10
4 mm .1575	5 mm	0.25 mm	30 mm	3.9 mm	2	6 mm	57 mm	MEFM-040-3000-25	61.85	MEFM-040-3000-25K	69.05
4 mm .1575	5 mm	0.5 mm	30 mm	3.9 mm	2	6 mm	57 mm	MEFM-040-3000-50	61.85	MEFM-040-3000-50K	69.05
4 mm .1575	5 mm	1 mm	30 mm	3.9 mm	2	6 mm	57 mm	MEFM-040-3000-100	61.85	MEFM-040-3000-100K	69.05
.1875 .1875	.188	.005	1.000	.183	2	.2500	2.5	MEF-187-1000-005	55.00	MEF-187-1000-005K	62.20
.1875 .1875	.188	.010	1.000	.183	2	.2500	2.5	MEF-187-1000-010	55.00	MEF-187-1000-010K	62.20
.1875 .1875	.188	.010	1.500	.183	2	.2500	3.0	MEF-187-1500-010	62.00	MEF-187-1500-010K	69.30
.1875 .1875	.188	.015	1.000	.183	2	.2500	2.5	MEF-187-1000-015	55.00	MEF-187-1000-015K	62.20
.1875 .1875	.188	.015	1.500	.183	2	.2500	3.0	MEF-187-1500-015	62.00	MEF-187-1500-015K	69.30
.1875 .1875	.188	.005	.750	.183	2	.2500	2.5	MEF-187-750-005	48.95	MEF-187-750-005K	56.15
.1875 .1875	.188	.015	.750	.183	2	.2500	2.5	MEF-187-750-015	48.95	MEF-187-750-015K	56.15
.1875 .1875	.188	.010	.750	.183	2	.2500	2.5	MEF-187-750-010	48.95	MEF-187-750-010K	56.15

\*.0005" / .013 mm max TIR

Continued on next page

# End Mills For Steels & High Temperature Alloys

## Corner Radius – 2 & 3 Flute – Long Reach, Stub Flute (cont.)

MEF / MEFM

Continued from previous page

Cutter Diameter*	Length of Cut	Corner Radius	Overall Reach	Neck Dia.	Flutes	Shank Dia.	Overall Length	Uncoated		nACRo® Coated	
								Tool #	Price	Tool #	Price
D1 +.0000" +.000mm -.0005" -.013mm	L2 +.015" +.38mm -.000" -.00mm	R +.0000" +.000mm -.0005" -.013mm	L3 +.010" +.25mm -.010" -.00mm	D3		D2 (h6)	L1	Tool #	Price	Tool #	Price
5 mm .1969	6 mm	0.25 mm	15 mm	4.9 mm	2	6 mm	57 mm	MEFM-050-1500-25	49.35	MEFM-050-1500-25K	56.55
5 mm .1969	6 mm	0.25 mm	25 mm	4.9 mm	2	6 mm	57 mm	MEFM-050-2500-25	56.35	MEFM-050-2500-25K	63.55
5 mm .1969	6 mm	0.25 mm	30 mm	4.9 mm	2	6 mm	57 mm			MEFM-050-3000-25K	69.05
5 mm .1969	6 mm	0.5 mm	30 mm	4.9 mm	2	6 mm	57 mm	MEFM-050-3000-50	61.85	MEFM-050-3000-50K	69.05
5 mm .1969	6 mm	1 mm	30 mm	4.9 mm	2	6 mm	57 mm	MEFM-050-3000-100	61.85	MEFM-050-3000-100K	69.05

D1 +.0000" +.000mm -.0005" -.013mm	L2 +.015" +.38mm -.000" -.00mm	R +.0000" +.000mm -.0005" -.013mm	L3 +.010" +.25mm -.010" -.00mm	D3	D2 (h6)	L1	Tool #	Price	Tool #	Price
.2500 .2500	.250 .005	.750 .246	2 .2500	2.5	MEF-250-750-005	48.95	MEF-250-750-005K	56.15		
.2500 .2500	.250 .010	.750 .246	2 .2500	2.5	MEF-250-750-010	48.95	MEF-250-750-010K	56.15		
.2500 .2500	.250 .015	.750 .246	2 .2500	2.5	MEF-250-750-015	48.95	MEF-250-750-015K	56.15		
.2500 .2500	.250 .010	1.000 .246	2 .2500	2.5	MEF-250-1000-010	55.00	MEF-250-1000-010K	62.20		
.2500 .2500	.250 .005	1.000 .246	2 .2500	2.5	MEF-250-1000-005	55.00	MEF-250-1000-005K	62.20		
.2500 .2500	.250 .015	1.000 .246	2 .2500	2.5	MEF-250-1000-015	55.00	MEF-250-1000-015K	62.20		

\*.0005" / .013 mm max TIR

Steels & High Temp. Alloys

VHS / VHSM  
VHM / VHMM

End Mills For Steels & High Temperature Alloys  
Corner Radius – 4 Flute – Variable Helix

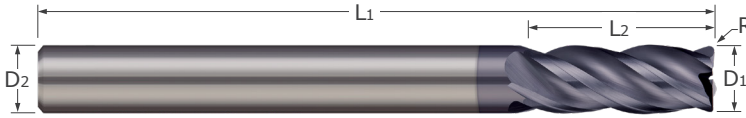

- Designed for high performance in titanium alloys, inconel, nickel alloys, and other high-temperature materials with outstanding performance in difficult-to-machine steels, stainless steels, and tool steels
- Variable helix design reduces chatter and harmonics and increases material removal rates
- Specialized geometry for maximum performance in high velocity tool paths
- Corner radius profile
- Weldon flat offered on sizes 3/8" and larger ■ Center cutting
- AlTiN coating option for added lubricity and increased wear resistance in difficult-to-machine materials
- Solid carbide ■ CNC ground in the USA

Cutter Diameter*			Length of Cut	Corner Radius	Flutes	Shank Diameter	Overall Length	Uncoated		AlTiN Coated	
D1 +.0000" -.0020" (h9) decimal equiv.	D2 (h6)	L1	L2 +.031" -.000" +.79 mm -.00 mm	R +.0000" -.0005" +.000 mm -.013 mm	4	D2 (h6)	L1	Tool #	Price	Tool #	Price
								3 mm	.1181	.1181	6 mm
3 mm	.1181	.1181	8 mm	0.5 mm	4	4 mm	50 mm			VHMM-030-4X	18.65
.1250	.1250	.1250	.500	.010	4	.1250	1.5			VHM-125-4X	15.95
4 mm	.1575	.1575	8 mm	0.5 mm	4	4 mm	50 mm	VHSM-040-4	20.25	VHSM-040-4X	23.15
4 mm	.1575	.1575	11 mm	0.5 mm	4	4 mm	50 mm	VHMM-040-4	22.50	VHMM-040-4X	25.40
.1875	.1875	.1875	.625	.010	4	.1875	2.0			VHM-187-4X	25.35
5 mm	.1969	.1969	16 mm	0.5 mm	4	6 mm	57 mm	VHMM-050-4	26.70		
6 mm	.2362	.2362	10 mm	0.5 mm	4	6 mm	57 mm	VHSM-060-4	24.00		
6 mm	.2362	.2362	16 mm	0.5 mm	4	6 mm	57 mm			VHMM-060-4X	31.60
.2500	.2500	.2500	.500	.020	4	.2500	2.5	VHS-250-4	23.80	VHS-250-4X	28.70
.3125	.3125	.3125	.500	.020	4	.3125	2.5			VHS-312-4X	34.70
.3125	.3125	.3125	.813	.020	4	.3125	2.5			VHM-312-4X	37.80
8 mm	.3150	.3150	16 mm	0.5 mm	4	8 mm	63 mm	VHSM-080-4	28.00		
8 mm	.3150	.3150	19 mm	0.5 mm	4	8 mm	63 mm	VHMM-080-4	31.15	VHMM-080-4X	37.95
.3750	.3750	.3750	.625	.020	4	.3750	2.5	VHS-375-4	31.55	VHS-375-4X	38.35
.3750	.3750	.3750	.875	.020	4	.3750	2.5	VHM-375-4	35.05		
10 mm	.3937	.3937	19 mm	0.5 mm	4	10 mm	72 mm	VHSM-100-4	35.82		
10 mm	.3937	.3937	22 mm	0.6 mm	4	10 mm	72 mm	VHMM-100-4	39.80	VHMM-100-4X	46.60
.4375	.4375	.4375	1.000	.020	4	.4375	2.5	VHM-437-4	54.70	VHM-437-4X	62.90
12 mm	.4724	.4724	22 mm	0.5 mm	4	12 mm	83 mm			VHSM-120-4X	61.40
12 mm	.4724	.4724	26 mm	0.6 mm	4	12 mm	83 mm	VHMM-120-4	56.75	VHMM-120-4X	67.05
.5000	.5000	.5000	.625	.030	4	.5000	3.0	VHS-500-4	54.55		
.5000	.5000	.5000	1.000	.030	4	.5000	3.0			VHM-500-4X	68.80
.5000	.5000	.5000	1.250	.030	4	.5000	3.5	VHM-5125-4	63.65	VHM-5125-4X	70.80
14 mm	.5512	.5512	26 mm	0.7 mm	4	14 mm	83 mm			VHMM-140-4X	110.65
20 mm	.7874	.7874	38 mm	0.8 mm	4	20 mm	104 mm	VHMM-200-4	186.35		
25 mm	.9843	.9843	38 mm	0.8 mm	4	25 mm	127 mm			VHMM-250-4X	285.75

\*.0005" / .013 mm max TIR

# End Mills For Steels & High Temperature Alloys

## Corner Radius – 4 & 5 Flute – Variable Helix – Long Flute

VLM



Steels & High Temp. Alloys

- Designed for high performance in titanium alloys, inconel, nickel alloys, and other high-temperature materials with outstanding performance in difficult-to-machine steels, stainless steels, and tool steels
- Variable helix design reduces chatter and harmonics and increases material removal rates
- Specialized geometry for maximum performance in high velocity tool paths
- Long flutes for deep pocket milling
- Corner radius profile
- Weldon flat offered on sizes 3/8" and larger
- Center cutting
- AlTiN coating option for added lubricity and increased wear resistance in difficult-to-machine materials
- nACRo® coating option for added heat resistance in difficult to machine materials
- Solid carbide
- CNC ground in the USA

Cutter Diameter	Length of Cut	Corner Radius	Flutes	Shank Dia.	Overall Length	Uncoated		AlTiN Coated		nACRo® Coated	
						Tool #	Price	Tool #	Price	Tool #	Price
D1 $\begin{smallmatrix} +.0000" \\ -.0020" \end{smallmatrix}$	L2 $\begin{smallmatrix} +.030" \\ -.000" \end{smallmatrix}$	R $\begin{smallmatrix} +.0000" \\ -.0005" \end{smallmatrix}$		D2 (h6)	L1						
.1875	.750	.0100	4	.1875	2.5			VLM-187-4X	30.90		
.2500	1.125	.0200	4	.2500	3.0	VLM-250-4	33.70	VLM-250-4X	38.60		
.2500	1.125	.0200	5	.2500	3.0	VLM-250-5-020	37.75			VLM-250-5-020K	44.95
D1 $\begin{smallmatrix} +.0000" \\ -.0020" \end{smallmatrix}$	L2 $\begin{smallmatrix} +.030" \\ -.000" \end{smallmatrix}$	R $\begin{smallmatrix} +.0000" \\ -.0005" \end{smallmatrix}$		D2 (h6)	L1	Tool #	Price	Tool #	Price	Tool #	Price
.3125	1.125	.0200	4	.3125	3.0	VLM-312-4	37.60	VLM-312-4X	44.40		
.3125	1.125	.0200	5	.3125	3.0					VLM-312-5-020K	51.30
.3750	1.250	.0200	5	.3750	3.0	VLM-375-5-020	50.50			VLM-375-5-020K	60.30
.5000	2.250	.0300	4	.5000	4.5	VLM-500-4	80.60	VLM-500-4X	92.60		
.5000	1.750	.0600	5	.5000	4.5	VLM-500-5-060	85.50			VLM-500-5-060K	102.60
.5000	1.750	.0900	5	.5000	4.5	VLM-500-5-090	85.50			VLM-500-5-090K	102.60
.5000	1.750	.1250	5	.5000	4.5	VLM-500-5-125	85.50			VLM-500-5-125K	102.60
.6250	2.250	.0300	4	.6250	5.0			VLM-625-4X	159.50		

VLR / VLRM

**End Mills For Steels & High Temperature Alloys**  
 Corner Radius – 4 Flute – Variable Helix – Long Reach – Reduced Neck

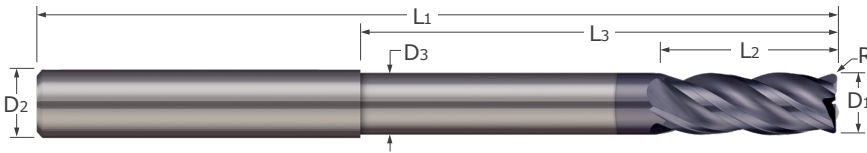

- Designed for high performance in titanium alloys, inconel, nickel alloys, and other high-temperature materials with outstanding performance in difficult-to-machine steels, stainless steels, and tool steels
- Variable helix design reduces chatter and harmonics and increases material removal rates
- Specialized geometry for maximum performance in high velocity tool paths
- Long reach for deep pocket milling
- Corner radius profile
- Weldon flat offered on sizes 3/8" and larger
- Center cutting
- AlTiN coating option for added lubricity and increased wear resistance in difficult-to-machine materials
- Solid carbide
- CNC ground in the USA

Steels & High Temp. Alloys

Cutter Diameter*	Length of Cut	Corner Radius	Overall Reach	Neck Diameter	Flutes	Shank Dia.	Overall Length	Uncoated		AlTiN Coated	
								Tool #	Price	Tool #	Price
D1 +.0000" (h9) -.0020" decimal equiv.	L2 +.010" - .000" +.25 mm - .00 mm	R +.0000" - .0005" +.000mm - .013mm	L3 +.015" - .000" +.38 mm - .00 mm	D3	4	D2 (h6)	L1	Tool #	Price	Tool #	Price
6 mm .2500	8 mm .500	0.5 mm .020	30 mm 2.500	5.49 mm .230	4	6 mm .2500	75 mm 4.0	VLRM-060-4	45.45	VLRM-060-4X	50.35
										VLR-250-4X	49.70
D1 +.0000" (h9) -.0030" decimal equiv.	L2 +.010" - .000" +.25 mm - .00 mm	R +.0000" - .0005" +.000mm - .013mm	L3 +.015" - .000" +.38 mm - .00 mm	D3	4	D2 (h6)	L1	Tool #	Price	Tool #	Price
.3125 8 mm .3150	.625 10 mm .3150	.020 0.5 mm .020	2.625 50 mm 7.49 mm	.293 7.49 mm .355	4	.3125 8 mm .3750	4.0 100 mm 4.0	VLR-312-4	48.20	VLR-312-4X	56.60
.3750 10 mm .3937	.750 12 mm .3937	.020 0.6 mm .020	2.750 50 mm 9.5 mm	.355 9.5 mm .480	4	.3750 10 mm .5000	4.0 100 mm 6.0	VLR-375-4	65.95	VLR-375-4X	74.35
.5000 14 mm .5512	1.000 18 mm .5512	.030 0.7 mm .030	4.500 65 mm 13.5 mm	.480 13.5 mm .605	4	.5000 14 mm .6250	6.0 120 mm 6.0	VLRM-100-4	72.30	VLR-500-4X	132.20
.6250 16 mm .6299	1.250 22 mm .6299	.030 0.7 mm .030	4.500 80 mm 15.49 mm	.605 15.49 mm .730	4	.6250 16 mm .7500	6.0 130 mm 6.0	VLRM-500-4	118.20	VLRM-140-4X	135.50
.7500 16 mm .7500	1.500 22 mm .7500	.030 0.7 mm .030	4.500 80 mm 15.49 mm	.730 15.49 mm .730	4	.7500 16 mm .7500	6.0 130 mm 6.0	VLRM-160-4	216.55	VLR-625-4X	203.65
								VLR-750-4	244.60		

\*.0005" / .013 mm max TIR

# End Mills For Steels & High Temperature Alloys

ARC

## Corner Radius – 5 Flute

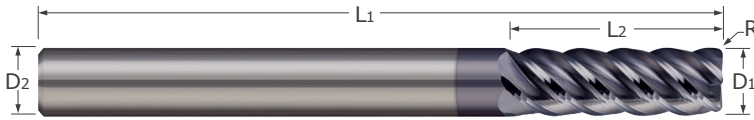

- Designed for roughing in titanium alloys, inconel, nickel alloys, and other high-temperature materials with outstanding performance in difficult-to-machine steels, stainless steels, and tool steels
- 45° high helix for reduced cutting forces and increased material removal rates
- Corner radius profile
- Weldon flat offered on sizes 3/8" and larger
- Center cutting
- AlTiN coating option for added lubricity and increased wear resistance in difficult-to-machine materials
- Solid carbide
- CNC ground in the USA

Steels & High Temp. Alloys

Cutter Diameter	Length of Cut	Corner Radius	Flutes	Shank Dia.	Overall Length	Uncoated		AlTiN Coated	
						Tool #	Price	Tool #	Price
D1 $\begin{matrix} +.0000" \\ -.0020" \end{matrix}$	L2 $\begin{matrix} +.030" \\ -.000" \end{matrix}$	R $\begin{matrix} +.0000" \\ -.0005" \end{matrix}$		D2 (h6)	L1				
.1875	.625	.0100	5	.1875	2.0	ARC-187-5-010	26.60	ARC-187-5-010X	29.50
.1875	.625	.0200	5	.1875	2.0			ARC-187-5-020X	29.50
.1875	.625	.0300	5	.1875	2.0	ARC-187-5-030	26.60	ARC-187-5-030X	29.50
.2500	.750	.0100	5	.2500	2.5			ARC-250-5-010X	38.05
.2500	.750	.0300	5	.2500	2.5			ARC-250-5-030X	38.05

D1 $\begin{matrix} +.0000" \\ -.0030" \end{matrix}$	L2 $\begin{matrix} +.030" \\ -.000" \end{matrix}$	R $\begin{matrix} +.0000" \\ -.0005" \end{matrix}$	Flutes	D2 (h6)	L1	Uncoated		AlTiN Coated	
						Tool #	Price	Tool #	Price
.3125	.813	.0200	5	.3125	2.5			ARC-312-5-020X	43.80
.3750	.875	.0100	5	.3750	2.5	ARC-375-5-010	42.00		
.3750	.875	.0200	5	.3750	2.5			ARC-375-5-020X	48.80
.3750	.875	.0300	5	.3750	2.5			ARC-375-5-030X	48.80
.3750	.875	.0600	5	.3750	2.5	ARC-375-5-060	42.00	ARC-375-5-060X	48.80
.5000	1.000	.0100	5	.5000	3.0	ARC-500-5-010	72.70		
.5000	1.000	.0600	5	.5000	3.0	ARC-500-5-060	72.70	ARC-500-5-060X	80.90
.6250	1.250	.0300	5	.6250	3.5	ARC-625-5-030	122.60		
.6250	1.250	.0900	5	.6250	3.5	ARC-625-5-090	122.60	ARC-625-5-090X	135.00
.7500	1.500	.0200	5	.7500	4.0	ARC-750-5-020	186.95	ARC-750-5-020X	201.25
.7500	1.500	.0600	5	.7500	4.0			ARC-750-5-060X	201.25
.7500	1.500	.0900	5	.7500	4.0	ARC-750-5-090	186.95		
1.0000	1.500	.0900	5	1.0000	4.0			ARC-001-5-090X	303.10



VHS / VHSM  
VHM / VHMM

End Mills For Steels & High Temperature Alloys  
Corner Radius – 5 Flute – Variable Helix

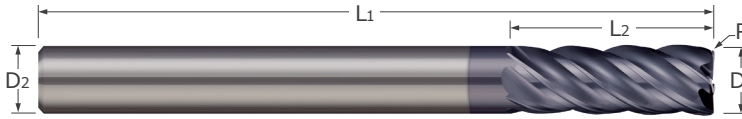

- Designed for high performance in titanium alloys, inconel, nickel alloys, and other high-temperature materials with outstanding performance in difficult-to-machine steels, stainless steels, and tool steels
- Variable helix design reduces chatter and harmonics and increases material removal rates
- Specialized geometry for maximum performance in high velocity tool paths
- Corner radius profile
- Weldon flat offered on sizes 3/8" and larger ■ Center cutting
- nACRo® coating option for added heat resistance in difficult to machine materials
- Solid carbide ■ CNC ground in the USA

Cutter Diameter*		Length of Cut	Corner Radius	Flutes	Shank Diameter	Overall Length	Uncoated		nACRo® Coated	
D1 +.0000" -.0020"	(h9) decimal equiv.	L2	R +.0000" -.0005" +.000 mm -.013 mm		D2 (h6)	L1	Tool #	Price	Tool #	Price
3 mm	.1181	6 mm	0.3 mm	5	4 mm	50 mm	VHSM-030-5	15.75	VHSM-030-5K	20.35
3 mm	.1181	8 mm	0.3 mm	5	4 mm	50 mm	VHMM-030-5	17.50	VHMM-030-5K	22.10
4 mm	.1575	8 mm	0.3 mm	5	4 mm	50 mm	VHSM-040-5	22.30	VHSM-040-5K	26.90
4 mm	.1575	11 mm	0.3 mm	5	4 mm	50 mm	VHMM-040-5	24.75	VHMM-040-5K	29.35
6 mm	.2362	10 mm	0.5 mm	5	6 mm	57 mm	VHSM-060-5	26.35	VHSM-060-5K	33.55
6 mm	.2362	16 mm	0.5 mm	5	6 mm	57 mm	VHMM-060-5	29.30	VHMM-060-5K	36.50
.2500	.2500	.500	.020	5	.2500	2.5	VHS-250-5-020	26.55	VHS-250-5-020K	33.75

D1 +.0000" -.0030"	(h9) decimal equiv.	L2	R +.0000" -.0005" +.000 mm -.013 mm	Flutes	D2 (h6)	L1	Tool #	Price	Tool #	Price
.3125	.3125	.500	.020	5	.3125	2.5	VHS-312-5-020	33.30	VHS-312-5-020K	43.10
.3125	.3125	.813	.020	5	.3125	2.5			VHM-312-5-020K	46.80
8 mm	.3150	16 mm	0.5 mm	5	8 mm	63 mm	VHSM-080-5	31.05	VHSM-080-5K	40.85
8 mm	.3150	19 mm	0.5 mm	5	8 mm	63 mm	VHMM-080-5	34.50	VHMM-080-5K	44.30
.3750	.3750	.625	.020	5	.3750	2.5	VHS-375-5-020	36.45	VHS-375-5-020K	46.25
.3750	.3750	.875	.020	5	.3750	2.5			VHM-375-5-020K	50.30
10 mm	.3937	19 mm	0.5 mm	5	10 mm	72 mm			VHSM-100-5K	49.40
10 mm	.3937	22 mm	0.5 mm	5	10 mm	72 mm			VHMM-100-5K	53.80
12 mm	.4724	22 mm	0.5 mm	5	12 mm	83 mm	VHSM-120-5	54.90	VHSM-120-5K	69.60
12 mm	.4724	26 mm	0.5 mm	5	12 mm	83 mm	VHMM-120-5	61.00	VHMM-120-5K	75.70
.5000	.5000	.625	.030	5	.5000	3.0	VHS-500-5-030	59.40	VHS-500-5-030K	71.20
.5000	.5000	1.000	.030	5	.5000	3.0			VHM-500-5-030K	77.80
.5000	.5000	.625	.060	5	.5000	3.0	VHS-500-5-060	59.40		
.5000	.5000	1.000	.060	5	.5000	3.0	VHM-500-5-060	66.00	VHM-500-5-060K	77.80
.5000	.5000	.625	.090	5	.5000	3.0	VHS-500-5-090	59.40	VHS-500-5-090K	71.20
.5000	.5000	1.000	.090	5	.5000	3.0	VHM-500-5-090	66.00	VHM-500-5-090K	77.80
.5000	.5000	1.000	.125	5	.5000	3.0	VHM-500-5-125	66.00	VHM-500-5-125K	77.80
.6250	.6250	1.250	.060	5	.6250	3.5	VHM-625-5-060	124.25	VHM-625-5-060K	141.65
.7500	.7500	1.500	.030	5	.7500	4.0			VHM-750-5-030K	203.00
.7500	.7500	1.500	.125	5	.7500	4.0	VHM-750-5-125	183.00	VHM-750-5-125K	203.00

\*.0005" / .013 mm max TIR

## End Mills For Steels & High Temperature Alloys

VLR

Corner Radius – 5 Flute – Variable Helix – Long Reach – Reduced Neck

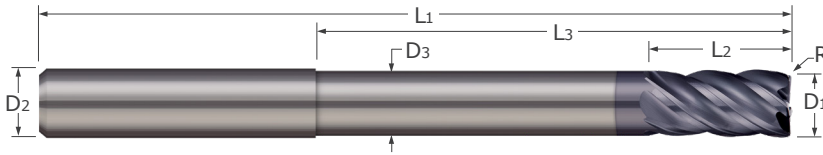

Steels & High Temp. Alloys

- Designed for high performance in titanium alloys, inconel, nickel alloys, and other high-temperature materials with outstanding performance in difficult-to-machine steels, stainless steels, and tool steels
- Variable helix design reduces chatter and harmonics and increases material removal rates
- Specialized geometry for maximum performance in high velocity tool paths
- Long reach for deep pocket milling
- Corner radius profile
- Weldon flat offered on sizes 3/8" and larger
- Center cutting
- nACRo® coating option for added heat resistance in difficult to machine materials
- Solid carbide
- CNC ground in the USA

Cutter Diameter	Length of Cut	Corner Radius	Overall Reach	Neck Diameter	Flutes	Shank Dia.	Overall Length	Uncoated		nACRo® Coated	
								Tool #	Price	Tool #	Price
D1 $\begin{matrix} +.0000" \\ -.0020" \end{matrix}$	L2 $\begin{matrix} +.010" \\ -.000" \end{matrix}$	R $\begin{matrix} +.0000" \\ -.0005" \end{matrix}$	L3 $\begin{matrix} +.015" \\ -.000" \end{matrix}$	D3	5	D2 (h6)	L1	Tool #	Price	Tool #	Price
.2500	.500	.0200	2.500	.230	5	.2500	4.0	VLR-250-5-020	47.95	VLR-250-5-020K	56.25
D1 $\begin{matrix} +.0000" \\ -.0030" \end{matrix}$	L2 $\begin{matrix} +.010" \\ -.000" \end{matrix}$	R $\begin{matrix} +.0000" \\ -.0005" \end{matrix}$	L3 $\begin{matrix} +.015" \\ -.000" \end{matrix}$	D3	5	D2 (h6)	L1	Tool #	Price	Tool #	Price
.3125	.625	.0200	2.625	.292	5	.3125	4.0	VLR-312-5-020	51.00	VLR-312-5-020K	63.10
.3750	.750	.0200	2.750	.355	5	.3750	4.0	VLR-375-5-020	70.50	VLR-375-5-020K	82.60
.5000	1.000	.0300	4.500	.480	5	.5000	6.0	VLR-500-5-030	125.00	VLR-500-5-030K	144.90
.5000	1.000	.0600	4.500	.480	5	.5000	6.0	VLR-500-5-060	125.00	VLR-500-5-060K	144.90
.5000	1.000	.0900	4.500	.480	5	.5000	6.0	VLR-500-5-090	125.00	VLR-500-5-090K	144.90
.5000	1.000	.1250	4.500	.480	5	.5000	6.0			VLR-500-5-125K	144.90

ASM / ASMM

End Mills For Aluminum Alloys

Square – 2 Flute – Stub Flute



- Designed for exceptional performance in aluminum, non ferrous materials and soft materials
- 45° high helix for reduced cutting forces and increased material removal rates
- Stub flutes for maximum rigidity
- Square profile
- Center cutting
- ZrN coated option for high hardness, lubricity, and abrasion resistance
- Solid carbide ■ CNC ground in the USA

Aluminum Alloys

Cutter Diameter*			Length of Cut	Flutes	Shank Diameter	Overall Length	Uncoated		ZrN Coated	
D1	D1	decimal equiv.					L2	D2 (h6)	L1	Tool #
+ .0000" - .0020"	+ .00 mm - .05 mm		+ .030" - .000" + .51 mm - .00 mm							
2 mm	.0787		4 mm	2	4 mm	50 mm	ASMM-020-2	19.85		
.0938	.0938		.188	2	.1250	1.5			ASM-093-2S	18.00
3 mm	.1181		6 mm	2	6 mm	57 mm	ASMM-030-2	23.90		
.1563	.1563		.313	2	.1875	1.5	ASM-156-2	20.30	ASM-156-2S	24.40
.1875	.1875		.375	2	.1875	1.5	ASM-187-2	20.30		
6 mm	.2362		10 mm	2	6 mm	57 mm	ASMM-060-2	23.90	ASMM-060-2S	30.00
D1	D1	decimal equiv.	L2		D2 (h6)	L1	Tool #	Price	Tool #	Price
+ .0000" - .0030"	+ .00 mm - .08 mm		+ .030" - .000" + .51 mm - .00 mm							
.3125	.3125		.500	2	.3125	2.0	ASM-312-2	27.80		
.3750	.3750		.625	2	.3750	2.0	ASM-375-2	33.25	ASM-375-2S	39.95
10 mm	.3937		19 mm	2	10 mm	72 mm	ASMM-100-2	34.65		
.5000	.5000		.625	2	.5000	2.5	ASM-500-2	54.85	ASM-500-2S	64.65

\*.0005" / .013 mm max TIR

# End Mills For Aluminum Alloys

ARM / ARMM

## Square – 2 & 3 Flute



- Designed for exceptional performance in aluminum, non ferrous materials and soft materials
- 45° high helix for reduced cutting forces and increased material removal rates
- Square profile
- Center cutting
- ZrN coated option for high hardness, lubricity, and abrasion resistance
- Solid carbide ■ CNC ground in the USA

Aluminum Alloys

Cutter Diameter*			Length of Cut	Flutes	Shank Diameter	Overall Length	Uncoated		ZrN Coated	
D1 + .0000" - .0020"	(h8)	decimal equiv.	L2 + .030" - .000" + .78 mm - .00 mm	D2 (h6)	L1	Tool #	Price	Tool #	Price	
										1 mm
.0625	.0625	.188	2	.1250	1.5			ARM-062-2S	18.65	
2 mm	.0787	6 mm	2	4 mm	50 mm	ARMM-020-2	19.85	ARMM-020-2S	23.95	
.0938	.0938	.375	2	.1250	1.5			ARM-093-2S	18.65	
3 mm	.1181	10 mm	2	6 mm	57 mm	ARMM-030-2	25.10	ARMM-030-2S	31.20	
.1563	.1563	.563	2	.1875	2.0	ARM-156-2	21.20	ARM-156-2S	25.20	
4 mm	.1575	15 mm	2	6 mm	57 mm			ARMM-040-2S	31.20	
.1875	.1875	.625	2	.1875	2.0			ARM-187-2S	25.20	
5 mm	.1969	20 mm	2	6 mm	57 mm	ARMM-050-2	25.10	ARMM-050-2S	31.20	
6 mm	.2362	20 mm	2	6 mm	57 mm	ARMM-060-2	25.10	ARMM-060-2S	31.20	
6 mm	.2362	20 mm	3	6 mm	57 mm	ARMM-060-3	25.10	ARMM-060-3S	31.20	
.2500	.2500	.750	3	.2500	2.5			ARM-250-3S	32.70	

D1 + .0000" - .0030"	(h8)	decimal equiv.	L2 + .030" - .000" + .78 mm - .00 mm	D2 (h6)	L1	Tool #	Price	Tool #	Price
.2813	.2813	.750	3	.3125	2.5	ARM-281-3	31.00	ARM-281-3S	39.20
.3125	.3125	.813	3	.3125	2.5	ARM-312-3	31.00		
8 mm	.3150	25 mm	2	8 mm	63 mm			ARMM-080-2S	39.10
8 mm	.3150	25 mm	3	8 mm	63 mm	ARMM-080-3	31.00	ARMM-080-3S	39.10
.3750	.3750	.875	3	.3750	2.5	ARM-375-3	35.00		
10 mm	.3937	25 mm	2	10 mm	72 mm			ARMM-100-2S	44.55
10 mm	.3937	25 mm	3	10 mm	72 mm	ARMM-100-3	36.45		
12 mm	.4724	30 mm	2	12 mm	83 mm			ARMM-120-2S	70.10
12 mm	.4724	30 mm	3	12 mm	83 mm	ARMM-120-3	58.10	ARMM-120-3S	70.10
.5000	.5000	1.000	2	.5000	3.0	ARM-500-2	60.85		
.5000	.5000	1.000	3	.5000	3.0			ARM-500-3S	70.65
.5000	.5000	1.250	2	.5000	3.5	ARM-5125-2	63.90		
.5000	.5000	1.250	3	.5000	3.5	ARM-5125-3	63.90		
14 mm	.5510	30 mm	3	14 mm	83 mm	ARMM-140-3	67.50		

\*.0005" / .013 mm max TIR

Continued on next page

ARM / ARMM

End Mills For Aluminum Alloys

Square – 2 & 3 Flute (cont.)

Continued from previous page

Cutter Diameter*			Length of Cut	Flutes	Shank Diameter	Overall Length	Uncoated		ZrN Coated	
D1 +.0000" -.0030" (h8)	decimal equiv.	L2 +.030" -.000" +.78 mm -.00 mm	D2 (h6)	L1	Tool #	Price	Tool #	Price		
.6250	.6250	1.250	3	.6250	3.5	ARM-625-3	107.60			
16 mm	.6299	35 mm	2	16 mm	92 mm	ARMM-160-2	108.35	ARMM-160-2S	122.65	
16 mm	.6299	35 mm	3	16 mm	92 mm			ARMM-160-3S	122.65	
18 mm	.7087	45 mm	3	18 mm	92 mm	ARMM-180-3	144.55			
.7500	.7500	1.500	3	.7500	4.0			ARM-750-3S	180.40	
20 mm	.7874	45 mm	2	20 mm	104 mm	ARMM-200-2	183.75			
20 mm	.7874	45 mm	3	20 mm	104 mm			ARMM-200-3S	206.25	

\*.0005" / .013 mm max TIR

# End Mills For Aluminum Alloys

## Square – Single Flute – Upcut Router

SFA / SFAM

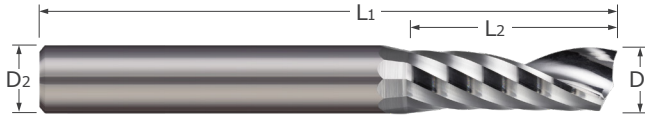

- Single flute design for applications in aluminum and non-ferrous materials
- Polished flute improves chip evacuation and helps to reduce built up edge
- Optimized geometry for increased material removal rates
- End cutting
- Solid carbide
- CNC ground in the USA

Aluminum Alloys

Cutter Diameter*			Length of Cut	Shank Diameter	Overall Length	Uncoated	
D1			L2	D2 (h6)	L1	Tool #	Price
+ .0000" - .0020"	+ .00 mm - .05 mm	decimal equiv.	+ .015" - .000" + .38 mm - .00 mm				
.0625	.0625	.0625	.250	.1250	1.5	SFA-062-22	26.45
.0625	.0625	.0625	.250	.2500	2.0	SFA-062-42	31.10
	2 mm	.0787	6 mm	6 mm	57 mm	SFAM-020020	29.20
	3 mm	.1181	12 mm	6 mm	57 mm	SFAM-030020	29.20
.1250	.1250	.1250	.250	.1250	1.5	SFA-125-22	23.35
.1250	.1250	.1250	.250	.2500	2.0	SFA-125-42	27.20
.1250	.1250	.1250	.500	.1250	1.5	SFA-125-24	23.35
.1250	.1250	.1250	.500	.2500	2.0	SFA-125-44	27.20
.1562	.1562	.1562	.625	.2500	2.0	SFA-156-45	27.20
	4 mm	.1575	16 mm	6 mm	57 mm	SFAM-040020	29.20
.1875	.1875	.1875	.500	.1875	2.0	SFA-187-33	25.80
.1875	.1875	.1875	.500	.2500	2.0	SFA-187-44	27.20
.1875	.1875	.1875	.625	.1875	2.0	SFA-187-35	25.80
.1875	.1875	.1875	.625	.2500	2.0	SFA-187-45	27.20
	5 mm	.1969	20 mm	6 mm	57 mm	SFAM-050025	29.20
.2188	.2188	.2188	.750	.2500	2.5	SFA-218-46	27.20
	6 mm	.2362	20 mm	6 mm	100 mm	SFAM-060100	43.75
	6 mm	.2362	25 mm	6 mm	57 mm	SFAM-060030	29.20
.2500	.2500	.2500	.375	.2500	2.5	SFA-250-43	27.20
.2500	.2500	.2500	.750	.2500	2.5	SFA-250-46	27.20
.2500	.2500	.2500	1.250	.2500	3.0	SFA-250-410	30.65
	8 mm	.3150	20 mm	8 mm	100 mm	SFAM-080100	55.90
	8 mm	.3150	30 mm	8 mm	75 mm	SFAM-080040	44.80
.3750	.3750	.3750	1.125	.3750	3.0	SFA-375-69	40.75
	10 mm	.3937	25 mm	10 mm	120 mm	SFAM-100100	68.10
	10 mm	.3937	35 mm	10 mm	90 mm	SFAM-100050	59.55
	12 mm	.4724	40 mm	12 mm	90 mm	SFAM-120050	73.85
.5000	.5000	.5000	1.000	.5000	3.0	SFA-500-88	67.50
.5000	.5000	.5000	1.500	.5000	4.0	SFA-500-812	71.00
	20 mm	.7874	40 mm	20 mm	150 mm	SFAM-200100	290.40
	20 mm	.7874	50 mm	20 mm	100 mm	SFAM-200050	222.70

\*.0005" / .013 mm max TIR

ARC

End Mills For Aluminum Alloys  
Corner Radius – 2 & 3 Flute

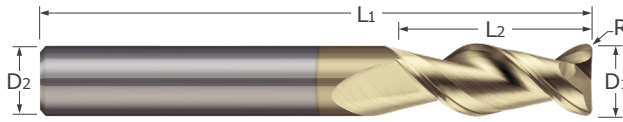

- Designed for exceptional performance in aluminum, non ferrous materials and soft materials
- 45° high helix for reduced cutting forces and increased material removal rates
- Stub flutes for maximum rigidity
- Corner radius profile
- Center cutting
- ZrN coated option for high hardness, lubricity, and abrasion
- Solid carbide ■ CNC ground in the USA

Cutter Diameter	Length of Cut	Corner Radius	Flutes	Shank Dia.	Overall Length	Uncoated		ZrN Coated	
						Tool #	Price	Tool #	Price
D1 $^{+.0000}$ / $_{-.0020}$ "	L2 $^{+.030}$ / $_{-.000}$ "	R $^{+.0000}$ / $_{-.0005}$ "		D2 (h6)	L1				
.0625	.188	.0050	2	.1250	1.5	ARC-062-2-005	17.25		
.0938	.375	.0100	2	.1250	1.5	ARC-093-2-010	17.25		
.1250	.500	.0100	2	.1250	1.5	ARC-125-2-010	17.25	ARC-125-2-010S	20.95
.2500	.750	.0100	2	.2500	2.5	ARC-250-2-010	30.50		
.2500	.750	.0300	3	.2500	2.5	ARC-250-3-030	30.50	ARC-250-3-030S	36.60

D1 $^{+.0000}$ / $_{-.0030}$ "	L2 $^{+.030}$ / $_{-.000}$ "	R $^{+.0000}$ / $_{-.0005}$ "	Flutes	D2 (h6)	L1	Uncoated		ZrN Coated	
						Tool #	Price	Tool #	Price
.3125	.813	.0300	2	.3125	2.5	ARC-312-2-030	34.15	ARC-312-2-030S	42.35
.3125	.813	.0300	3	.3125	2.5	ARC-312-3-030	34.15		
.3750	.875	.0100	2	.3750	2.5	ARC-375-2-010	38.60	ARC-375-2-010S	46.80
.5000	1.000	.0300	3	.5000	3.0	ARC-500-3-030	67.00	ARC-500-3-030S	76.80
.5000	1.000	.0600	3	.5000	3.0	ARC-500-3-060	67.00		
.5000	1.250	.0300	3	.5000	3.5	ARC-5125-3-030	70.35		
.6250	1.250	.0200	2	.6250	3.5	ARC-625-2-020	118.30		
.6250	1.250	.0300	2	.6250	3.5	ARC-625-2-030	118.30		
.6250	1.250	.0600	2	.6250	3.5	ARC-625-2-060	118.30		
.6250	1.250	.0600	3	.6250	3.5	ARC-625-3-060	118.30		
.6250	1.250	.0900	2	.6250	3.5	ARC-625-2-090	118.30		
.6250	1.250	.0900	3	.6250	3.5	ARC-625-3-090	118.30		
.7500	1.500	.0600	2	.7500	4.0	ARC-750-2-060	172.25		
.7500	1.500	.0900	2	.7500	4.0	ARC-750-2-090	172.25		
1.0000	1.500	.0200	2	1.0000	4.0	ARC-001-2-020	260.90		
1.0000	1.500	.0300	2	1.0000	4.0	ARC-001-2-030	260.90	ARC-001-2-030S	283.30
1.0000	1.500	.0600	2	1.0000	4.0	ARC-001-2-060	260.90	ARC-001-2-060S	283.30
1.0000	1.500	.0900	2	1.0000	4.0	ARC-001-2-090	260.90	ARC-001-2-090S	283.30
1.0000	1.500	.1250	2	1.0000	4.0	ARC-001-2-125	260.90	ARC-001-2-125S	283.30

\* .0005" max TIR

# End Mills For Plastics & Composites

SFP / SFPM

Square – Single Flute – Upcut Router

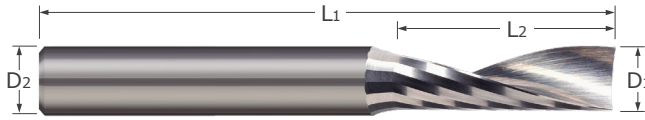

- Single flute design for applications in plastics
- Polished flute improves chip evacuation
- Optimized geometry for increased material removal rates
- End cutting ■ Solid carbide ■ CNC ground in the USA

Plastics & Composites

Cutter Diameter*			Length of Cut	Shank Diameter	Overall Length	Uncoated	
D1 +.0000" -.0020"	+.00 mm -.05 mm	decimal equiv.	L2 +.015" -.000" +.38 mm -.00 mm	D2 (h6)	L1	Tool #	Price
						1 mm	.0394
.0625	.0625	.0625	.250	.1250	1.50	SFP-062-22	26.45
.0625	.0625	.0625	.250	.2500	2.00	SFP-062-42	31.10
2 mm	.0787	.0787	6 mm	3 mm	57 mm	SFPM-020-10	25.30
2 mm	.0787	.0787	10 mm	3 mm	38 mm	SFPM-020-20	22.90
2 mm	.0787	.0787	12 mm	3 mm	57 mm	SFPM-020-30	25.30
2 mm	.0787	.0787	14 mm	3 mm	75 mm	SFPM-020-40	29.20
3 mm	.1181	.1181	8 mm	3 mm	57 mm	SFPM-030-10	25.30
3 mm	.1181	.1181	8 mm	6 mm	57 mm	SFPM-030-50	27.70
3 mm	.1181	.1181	12 mm	3 mm	38 mm	SFPM-030-20	22.90
3 mm	.1181	.1181	18 mm	6 mm	57 mm	SFPM-030-60	29.85
3 mm	.1181	.1181	18 mm	6 mm	75 mm	SFPM-030-70	36.60
.1250	.1250	.1250	.250	.1250	1.50	SFP-125-22	23.35
.1250	.1250	.1250	.250	.2500	2.00	SFP-125-42	27.20
.1250	.1250	.1250	.500	.1250	1.50	SFP-125-24	23.35
.1250	.1250	.1250	.500	.2500	2.00	SFP-125-44	27.20
.1562	.1562	.1562	.625	.2500	2.00	SFP-156-45	27.20
4 mm	.1575	.1575	12 mm	4 mm	50 mm	SFPM-040-10	26.85
4 mm	.1575	.1575	12 mm	6 mm	57 mm	SFPM-040-50	27.70
4 mm	.1575	.1575	15 mm	4 mm	50 mm	SFPM-040-20	24.70
4 mm	.1575	.1575	20 mm	6 mm	57 mm	SFPM-040-60	29.85
4 mm	.1575	.1575	20 mm	6 mm	75 mm	SFPM-040-70	36.60
4 mm	.1575	.1575	20 mm	8 mm	100 mm	SFPM-040-80	41.75
.1875	.1875	.1875	.500	.1875	2.00	SFP-187-33	25.80
.1875	.1875	.1875	.500	.2500	2.00	SFP-187-44	27.20
.1875	.1875	.1875	.625	.1875	2.00	SFP-187-35	25.80
.1875	.1875	.1875	.625	.2500	2.00	SFP-187-45	27.20
5 mm	.1969	.1969	16 mm	5 mm	50 mm	SFPM-050-10	34.25
5 mm	.1969	.1969	16 mm	6 mm	57 mm	SFPM-050-40	35.85
5 mm	.1969	.1969	20 mm	8 mm	95 mm	SFPM-050-70	41.75
5 mm	.1969	.1969	28 mm	6 mm	57 mm	SFPM-050-50	35.85
5 mm	.1969	.1969	28 mm	6 mm	75 mm	SFPM-050-60	38.45

\*.0005" / .013 mm max TIR

Continued on next page



## SFP / SFPM

## End Mills For Plastics & Composites

### Square – Single Flute – Upcut Router (cont.)

Continued from previous page

Cutter Diameter*			Length of Cut	Shank Diameter	Overall Length	Uncoated	
D <sub>1</sub> +.0000" -.0020"	+.00 mm -.05 mm	decimal equiv.	L <sub>2</sub> +.015" -.000" +.38 mm -.00 mm	D <sub>2</sub> (h6)	L <sub>1</sub>	Tool #	Price
						6 mm	.2362
6 mm	.2362	20 mm	6 mm	57 mm	SFPM-060-20	36.60	
6 mm	.2362	20 mm	8 mm	95 mm	SFPM-060-60	41.75	
6 mm	.2362	35 mm	6 mm	75 mm	SFPM-060-30	38.45	
6 mm	.2362	35 mm	8 mm	75 mm	SFPM-060-50	44.05	
.2500	.2500	.375	.2500	2.50	SFP-250-43	27.20	
.2500	.2500	.750	.2500	2.50	SFP-250-46	27.20	
.2500	.2500	1.250	.2500	3.00	SFP-250-410	30.65	
8 mm	.3150	18 mm	8 mm	50 mm	SFPM-080-10	32.20	
8 mm	.3150	22 mm	8 mm	63 mm	SFPM-080-20	34.75	
8 mm	.3150	30 mm	8 mm	75 mm	SFPM-080-30	41.75	
8 mm	.3150	40 mm	8 mm	100 mm	SFPM-080-40	53.25	
.3750	.3750	1.125	.3750	3.00	SFP-375-69	40.75	
10 mm	.3937	25 mm	10 mm	72 mm	SFPM-100-10	44.70	
10 mm	.3937	30 mm	10 mm	150 mm	SFPM-100-30	78.70	
10 mm	.3937	55 mm	10 mm	100 mm	SFPM-100-20	63.35	
12 mm	.4724	30 mm	12 mm	83 mm	SFPM-120-10	68.25	
12 mm	.4724	40 mm	12 mm	150 mm	SFPM-120-20	101.70	
.5000	.5000	1.000	.5000	3.00	SFP-500-88	67.50	
.5000	.5000	1.500	.5000	4.00	SFP-500-812	71.00	

\*.0005" / .013 mm max TIR

# End Mills For Plastics & Composites

## Square – Single Flute – Downcut Router

SFL / SLFM

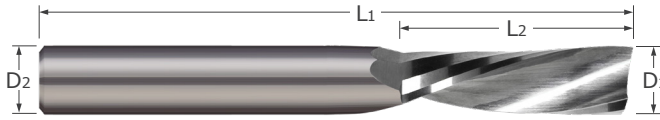

- Single flute design for applications in plastics and composites
- Left hand spiral routers drive chips downward, preventing delamination in multi-layered workpieces
- Polished flute improves chip evacuation
- Optimized geometry for increased material removal rates
- End cutting
- Solid carbide ■ CNC ground in the USA

Plastics & Composites

Cutter Diameter*			Length of Cut	Shank Diameter	Overall Length	Uncoated	
D1 +.0000" -.0020"	+.00 mm -.05 mm	decimal equiv.	L2 +.015" -.000" +.38 mm -.00 mm	D2 (h6)	L1	Tool #	Price
						1 mm	.0394
.0625	.0625	.0625	.250	.2500	2.0	SFL-062-42	31.10
2 mm	.0787	6 mm	3 mm	57 mm	SFLM-020-10	25.30	
2 mm	.0787	12 mm	3 mm	57 mm	SFLM-020-30	25.30	
2 mm	.0787	14 mm	3 mm	75 mm	SFLM-020-40	29.20	
3 mm	.1181	8 mm	3 mm	57 mm	SFLM-030-10	25.30	
3 mm	.1181	12 mm	3 mm	38 mm	SFLM-030-20	22.90	
3 mm	.1181	18 mm	6 mm	57 mm	SFLM-030-60	29.85	
.1250	.1250	.250	.1250	1.5	SFL-125-22	23.35	
.1250	.1250	.250	.2500	2.0	SFL-125-42	27.20	
.1250	.1250	.500	.1250	1.5	SFL-125-24	23.35	
.1250	.1250	.500	.2500	2.0	SFL-125-44	27.20	
.1562	.1562	.625	.2500	2.0	SFL-156-45	27.20	
4 mm	.1575	12 mm	4 mm	57 mm	SFLM-040-10	26.85	
4 mm	.1575	12 mm	6 mm	57 mm	SFLM-040-50	27.70	
4 mm	.1575	15 mm	4 mm	40 mm	SFLM-040-20	24.70	
4 mm	.1575	20 mm	6 mm	57 mm	SFLM-040-60	29.85	
4 mm	.1575	20 mm	6 mm	75 mm	SFLM-040-70	36.60	
4 mm	.1575	20 mm	8 mm	95 mm	SFLM-040-80	41.75	
.1875	.1875	.500	.1875	2.0	SFL-187-33	25.80	
.1875	.1875	.500	.2500	2.0	SFL-187-44	27.20	
.1875	.1875	.625	.1875	2.0	SFL-187-35	25.80	
.1875	.1875	.625	.2500	2.0	SFL-187-45	27.20	
5 mm	.1969	16 mm	6 mm	50 mm	SFLM-050-40	35.85	
5 mm	.1969	20 mm	8 mm	95 mm	SFLM-050-70	41.75	
5 mm	.1969	28 mm	6 mm	60 mm	SFLM-050-50	35.85	
5 mm	.1969	28 mm	6 mm	75 mm	SFLM-050-60	38.45	
.2188	.2188	.750	.2500	2.5	SFL-218-46	27.20	
6 mm	.2362	16 mm	6 mm	50 mm	SFLM-060-10	35.85	
6 mm	.2362	20 mm	8 mm	95 mm	SFLM-060-60	41.75	
6 mm	.2362	20 mm	6 mm	60 mm	SFLM-060-20	36.60	
6 mm	.2362	35 mm	8 mm	75 mm	SFLM-060-50	44.05	

\*.0005" / .013 mm max TIR

Continued on next page

SFL / SFLM

End Mills For Plastics & Composites  
 Square – Single Flute – Downcut Router (cont.)

Continued from previous page

Cutter Diameter*			Length of Cut	Shank Diameter	Overall Length	Uncoated	
D1			L2	D2 (h6)	L1	Tool #	Price
+ .0000" - .0020"	+ .00 mm - .05 mm	decimal equiv.	+ .015" - .000" + .38 mm - .00 mm				
.2500		.2500	.375	.2500	2.5	SFL-250-43	27.20
.2500		.2500	.750	.2500	2.5	SFL-250-46	27.20
.2500		.2500	1.250	.2500	3.0	SFL-250-410	30.65
.3750		.3750	1.125	.3750	3.0	SFL-375-69	40.75
	12 mm	.4724	30 mm	12 mm	83 mm	SFLM-120-10	68.25
.5000		.5000	1.000	.5000	3.0	SFL-500-88	67.50
.5000		.5000	1.500	.5000	4.0	SFL-500-812	71.00

\*.0005" / .013 mm max TIR

# End Mills For Plastics & Composites

RDA

## Diamond Cut – No End Cut

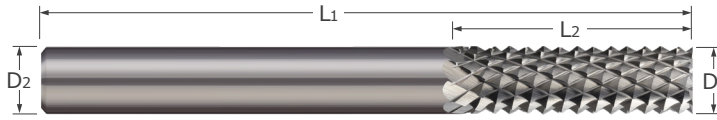

- Ideal for routing fiber reinforced, epoxy resin, and composites
- Diamond-cut flute pattern provides smooth cutting action and reduces delamination
- Non end-cutting
- Solid carbide
- CNC ground in the USA

Plastics & Composites

Cutter Diameter*	Length of Cut	Shank Dia.	Overall Length	Uncoated	
				Tool #	Price
$D_1 \begin{matrix} +.0000'' \\ -.0030'' \end{matrix}$	$L_2 \begin{matrix} +.030'' \\ -.000'' \end{matrix}$	$D_2 (h6)$	$L_1$		
.0625	.188	.1250	1.5	RDA-10	11.30
.0938	.375	.1250	1.5	RDA-20	11.30
.1250	.500	.1250	1.5	RDA-30	11.30
.1875	.625	.1875	2.0	RDA-40	16.00
.1875	.625	.2500	2.0	RDA-50	18.15
.2500	.750	.2500	2.0	RDA-60	19.40
.2500	.750	.2500	2.5	RDA-70	20.70
.2500	1.000	.2500	3.0	RDA-80	27.05
.3750	1.000	.3750	2.5	RDA-100	47.75
.5000	1.000	.5000	3.0	RDA-110	65.75

\*.0005" max TIR

RDB

End Mills For Plastics & Composites

Diamond Cut – Burr End Cut

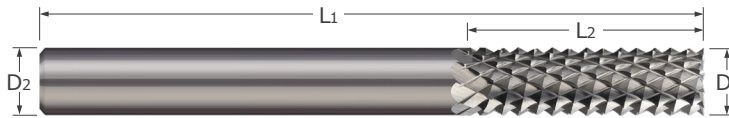

- Ideal for routing fiber reinforced, epoxy resin, and composites
- Diamond-cut flute pattern provides smooth cutting action and reduces delamination
- Burr end cut profile
- Solid carbide
- CNC ground in the USA

Cutter Diameter*	Length of Cut	Shank Dia.	Overall Length	Uncoated	
				Tool #	Price
D1 $^{+.0000''}$ $_{-.0030''}$	L2 $^{+.030''}$ $_{-.000''}$	D2 (h6)	L1		
.0625	.188	.1250	1.5	RDB-10	13.45
.0938	.375	.1250	1.5	RDB-20	13.45
.1250	.500	.1250	1.5	RDB-30	13.45
.1875	.625	.1875	2.0	RDB-40	19.20
.1875	.625	.2500	2.0	RDB-50	21.70
.2500	.750	.2500	2.0	RDB-60	23.10
.2500	.750	.2500	2.5	RDB-70	24.65
.2500	1.000	.2500	3.0	RDB-80	32.35
.3750	1.000	.3750	2.5	RDB-100	57.25
.5000	1.000	.5000	3.0	RDB-110	75.65

\*.0005" max TIR

## End Mills For Plastics & Composites

RDC

### Diamond Cut – End Mill Cut

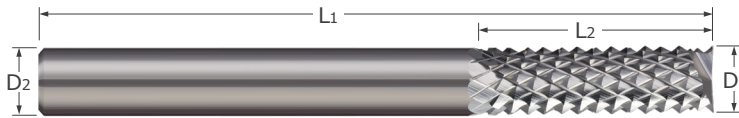

- Ideal for routing fiber reinforced, epoxy resin, and composites
- Diamond-cut flute pattern provides smooth cutting action and reduces delamination
- End mill end cut profile
- Solid carbide ■ CNC ground in the USA

Plastics & Composites

Cutter Diameter*	Length of Cut	Shank Dia.	Overall Length	Uncoated	
				Tool #	Price
D1 $\begin{matrix} +.0000'' \\ -.0030'' \end{matrix}$	L2 $\begin{matrix} +.030'' \\ -.000'' \end{matrix}$	D2 (h6)	L1		
.0938	.375	.1250	1.5	RDC-20	13.45
.1250	.500	.1250	1.5	RDC-30	13.45
.1875	.625	.1875	2.0	RDC-40	19.20
.1875	.625	.2500	2.0	RDC-50	21.70
.2500	.750	.2500	2.0	RDC-60	23.10
.2500	.750	.2500	2.5	RDC-70	24.65
.2500	1.000	.2500	3.0	RDC-80	32.35

\*.0005" max TIR

## End Mills For Plastics & Composites

RDD

### Diamond Cut – 135° Drill Point

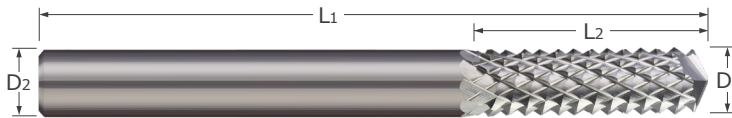

- Ideal for routing fiber reinforced, epoxy resin, and composites
- Diamond-cut flute pattern provides smooth cutting action and reduces delamination
- 135° drill point
- Solid carbide ■ CNC ground in the USA

Cutter Diameter*	Length of Cut	Shank Dia.	Overall Length	Uncoated	
				Tool #	Price
D1 $\begin{matrix} +.0000'' \\ -.0030'' \end{matrix}$	L2 $\begin{matrix} +.030'' \\ -.000'' \end{matrix}$	D2 (h6)	L1		
.0625	.188	.1250	1.5	RDD-10	13.45
.0938	.375	.1250	1.5	RDD-20	13.45
.1250	.500	.1250	1.5	RDD-30	13.45
.1875	.625	.1875	2.0	RDD-40	19.20
.1875	.625	.2500	2.0	RDD-50	21.70
.2500	.750	.2500	2.0	RDD-60	23.10
.2500	.750	.2500	2.5	RDD-70	24.65
.2500	1.000	.2500	3.0	RDD-80	32.35
.3125	1.000	.3125	2.5	RDD-90	43.10
.5000	1.000	.5000	3.0	RDD-110	75.65

\*.0005" max TIR

RDE

End Mills For Plastics & Composites

Diamond Cut – Fish Tail End Cut

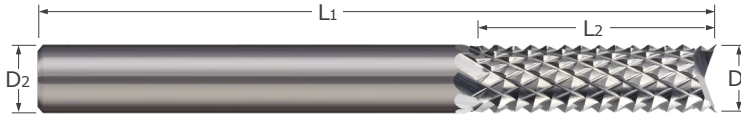

- Ideal for routing fiber reinforced, epoxy resin, and composites
- Diamond-cut flute pattern provides smooth cutting action and reduces delamination
- Less breakout when through-plunging
- Fish tail end cut profile
- Solid carbide
- CNC ground in the USA

Cutter Diameter*	Length of Cut	Shank Dia.	Overall Length	Uncoated	
				Tool #	Price
D <sub>1</sub> +.0000" -.0030"	L <sub>2</sub> +.030" -.000"	D <sub>2</sub> (h6)	L <sub>1</sub>		
.0938	.375	.1250	1.5	RDE-20	13.45
.1250	.500	.1250	1.5	RDE-30	13.45
.1875	.625	.1875	2.0	RDE-40	19.20
.1875	.625	.2500	2.0	RDE-50	21.70
.2500	.750	.2500	2.0	RDE-60	23.10
.2500	1.000	.2500	3.0	RDE-80	32.35
.3750	1.000	.3750	2.5	RDE-100	57.25
.5000	1.000	.5000	3.0	RDE-110	75.65

\*.0005" max TIR

# Undercutting End Mills

## 220°

SBM / SBMM

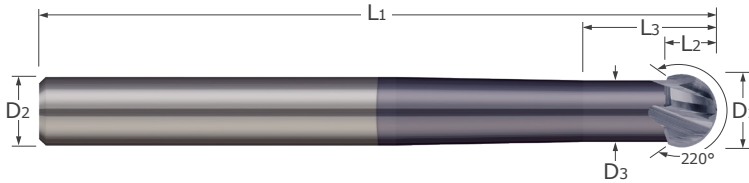

- Designed for undercutting, deburring, and multi-axis machining
- 220° spherical ball
- 30° helix
- Center cutting
- AlTiN coating option for added lubricity and increased wear resistance in difficult-to-machine materials
- Solid carbide ■ CNC ground in the USA

Undercutting End Mills

Cutter Diameter*	Length of Cut	Overall Reach	Neck Dia.	Flutes	Shank Dia.	Overall Length	Uncoated		AlTiN Coated	
							Tool #	Price	Tool #	Price
D1 +.0000" +.00mm -.0020" -.05mm	L2 L3	+ .030" -.000" + .78 mm -.00 mm	+ .003" -.005" D3 +.08mm -.13mm		D2 (h6)	L1				
2 mm .0787	1.3 mm	6 mm	1.3 mm	2	6 mm	75 mm			SBMM-020-206X	78.00
2 mm .0787	1.3 mm	6 mm	1.3 mm	4	6 mm	75 mm	SBMM-020-406	73.10	SBMM-020-406X	78.00
2 mm .0787	1.3 mm	10 mm	1.3 mm	2	6 mm	75 mm	SBMM-020-210	73.10	SBMM-020-210X	78.00
2 mm .0787	1.3 mm	10 mm	1.3 mm	4	6 mm	75 mm	SBMM-020-410	73.10	SBMM-020-410X	78.00
2 mm .0787	1.3 mm	16 mm	1.3 mm	2	6 mm	75 mm	SBMM-020-216	73.10	SBMM-020-216X	78.00
2 mm .0787	1.3 mm	16 mm	1.3 mm	3	6 mm	75 mm	SBMM-020-316	73.10	SBMM-020-316X	78.00
2 mm .0787	1.3 mm	16 mm	1.3 mm	4	6 mm	75 mm			SBMM-020-416X	78.00
3 mm .1181	2.0 mm	9 mm	2.0 mm	4	6 mm	75 mm			SBMM-030-409X	78.00
3 mm .1181	2.0 mm	15 mm	2.0 mm	2	6 mm	75 mm	SBMM-030-215	73.10	SBMM-030-215X	78.00
3 mm .1181	2.0 mm	15 mm	2.0 mm	4	6 mm	75 mm	SBMM-030-415	73.10	SBMM-030-415X	78.00
3 mm .1181	2.0 mm	21 mm	2.0 mm	2	6 mm	75 mm	SBMM-030-221	73.10	SBMM-030-221X	78.00
3 mm .1181	2.0 mm	21 mm	2.0 mm	3	6 mm	75 mm	SBMM-030-321	73.10	SBMM-030-321X	78.00
3 mm .1181	2.0 mm	21 mm	2.0 mm	4	6 mm	75 mm			SBMM-030-421X	78.00
.1250 .1250	.100 .250	.100	.100	4	.2500	3.0	SBM-125-4	73.10	SBM-125-4X	78.00
4 mm .1575	2.7 mm	12 mm	2.7 mm	2	6 mm	75 mm	SBMM-040-212	73.10	SBMM-040-212X	78.00
4 mm .1575	2.7 mm	12 mm	2.7 mm	4	6 mm	75 mm	SBMM-040-412	73.10	SBMM-040-412X	78.00
4 mm .1575	2.7 mm	20 mm	2.7 mm	2	6 mm	75 mm	SBMM-040-220	73.10	SBMM-040-220X	78.00
4 mm .1575	2.7 mm	20 mm	2.7 mm	4	6 mm	75 mm	SBMM-040-420	73.10	SBMM-040-420X	78.00
4 mm .1575	2.7 mm	32 mm	2.7 mm	2	6 mm	100 mm	SBMM-040-232	73.10	SBMM-040-232X	78.00
4 mm .1575	2.7 mm	32 mm	2.7 mm	4	6 mm	100 mm	SBMM-040-432	73.10	SBMM-040-432X	77.70
.1875 .1875	.150 .350	.150	.150	4	.2500	3.0	SBM-187-4	73.10	SBM-187-4X	78.00
6 mm .2362	4.0 mm	18 mm	4.0 mm	2	6 mm	75 mm	SBMM-060-218	73.10	SBMM-060-218X	78.00
6 mm .2362	4.0 mm	18 mm	4.0 mm	3	6 mm	75 mm	SBMM-060-318	73.10		
6 mm .2362	4.0 mm	18 mm	4.0 mm	4	6 mm	75 mm	SBMM-060-418	73.10	SBMM-060-418X	78.00
6 mm .2362	4.0 mm	30 mm	4.0 mm	2	6 mm	75 mm			SBMM-060-230X	78.00
6 mm .2362	4.0 mm	30 mm	4.0 mm	4	6 mm	75 mm	SBMM-060-430	73.10	SBMM-060-430X	78.00
6 mm .2362	4.0 mm	32 mm	4.0 mm	2	6 mm	100 mm	SBMM-060-248	73.10	SBMM-060-248X	78.00
6 mm .2362	4.0 mm	32 mm	4.0 mm	3	6 mm	100 mm	SBMM-060-348	73.10	SBMM-060-348X	78.00
6 mm .2362	4.0 mm	32 mm	4.0 mm	4	6 mm	100 mm	SBMM-060-448	73.10	SBMM-060-448X	77.70
.2500 .2500	.200 .500	.200	.200	2	.2500	3.0	SBM-250-2	73.10	SBM-250-2X	78.00
.2500 .2500	.200 .500	.200	.200	3	.2500	3.0	SBM-250-3	73.10	SBM-250-3X	78.00
.2500 .2500	.200 .500	.200	.200	4	.2500	3.0	SBM-250-4	73.10	SBM-250-4X	78.00

\*.0005" / .013 mm max TIR

Continued on next page



## SBM / SBMM

## Undercutting End Mills

220° (cont.)

Continued from previous page

Cutter Diameter*		Length of Cut	Overall Reach	Neck Dia.	Flutes	Shank Dia.	Overall Length	Uncoated		AlTiN Coated	
D <sub>1</sub> +.0000" -.0030"	+.00mm -.08mm	L <sub>2</sub>	L <sub>3</sub> +.030" -.000" +.78 mm -.00 mm	D <sub>3</sub> +.003" -.005" +.08mm -.13mm		D <sub>2</sub> (h6)	L <sub>1</sub>	Tool #	Price	Tool #	Price
.3125	.3125	.250	.600	.250	4	.3125	4.0	SBM-312-4	91.90		
8 mm	.3150	5.4 mm	24 mm	5.4 mm	3	8 mm	100 mm	SBMM-080-324	91.90		
8 mm	.3150	5.4 mm	24 mm	5.4 mm	4	8 mm	100 mm	SBMM-080-424	91.90	SBMM-080-424X	100.30
8 mm	.3150	5.4 mm	40 mm	5.4 mm	2	8 mm	100 mm	SBMM-080-240	91.90	SBMM-080-240X	100.30
8 mm	.3150	5.4 mm	40 mm	5.4 mm	3	8 mm	100 mm	SBMM-080-340	91.90	SBMM-080-340X	100.30
8 mm	.3150	5.4 mm	40 mm	5.4 mm	4	8 mm	100 mm			SBMM-080-440X	100.30
8 mm	.3150	5.4 mm	55 mm	5.4 mm	2	8 mm	100 mm			SBMM-080-264X	100.30
8 mm	.3150	5.4 mm	55 mm	5.4 mm	4	8 mm	100 mm			SBMM-080-464X	100.30
.3750	.3750	.300	.800	.300	2	.3750	4.0			SBM-375-2X	126.45
.3750	.3750	.300	.800	.300	4	.3750	4.0	SBM-375-4	118.05	SBM-375-4X	126.45
10 mm	.3937	6.7 mm	30 mm	6.7 mm	2	10 mm	100 mm	SBMM-100-230	123.95	SBMM-100-230X	132.35
10 mm	.3937	6.7 mm	30 mm	6.7 mm	4	10 mm	100 mm	SBMM-100-430	123.95	SBMM-100-430X	132.35
10 mm	.3937	6.7 mm	50 mm	6.7 mm	2	10 mm	100 mm	SBMM-100-250	123.95	SBMM-100-250X	132.35
10 mm	.3937	6.7 mm	50 mm	6.7 mm	4	10 mm	100 mm	SBMM-100-450	123.95	SBMM-100-450X	132.35
10 mm	.3937	6.7 mm	55 mm	6.7 mm	2	10 mm	100 mm	SBMM-100-272	123.95	SBMM-100-272X	132.35
10 mm	.3937	6.7 mm	55 mm	6.7 mm	4	10 mm	100 mm	SBMM-100-472	123.95	SBMM-100-472X	132.35
12 mm	.4724	8.0 mm	36 mm	8.0 mm	2	12 mm	100 mm	SBMM-120-236	144.95	SBMM-120-236X	155.25
12 mm	.4724	8.0 mm	36 mm	8.0 mm	4	12 mm	100 mm	SBMM-120-436	144.95	SBMM-120-436X	155.25
12 mm	.4724	8.0 mm	55 mm	8.0 mm	4	12 mm	100 mm			SBMM-120-472X	155.25
.5000	.5000	.400	.900	.400	2	.5000	4.0	SBM-500-2	146.85	SBM-500-2X	157.15
.5000	.5000	.400	.900	.400	4	.5000	4.0	SBM-500-4	146.85	SBM-500-4X	157.15
.6250	.6250	.500	1.000	.500	2	.6250	4.0	SBM-625-2	182.60	SBM-625-2X	195.00
.6250	.6250	.500	1.000	.500	3	.6250	4.0	SBM-625-3	182.60	SBM-625-3X	195.00
.6250	.6250	.500	1.000	.500	4	.6250	4.0	SBM-625-4	182.60	SBM-625-4X	195.00

\*.0005" / .013 mm max TIR

# Drill/End Mills

## 2 & 4 Flute

### DM / DMM

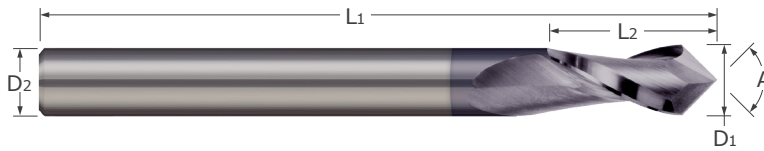

- Designed for chamfering, milling, and some spotting applications
- 2 flute design effective in spotting and drilling applications
- AlTiN coating option for added lubricity and increased wear resistance in difficult-to-machine materials
- 30° helix ■ Solid carbide ■ CNC ground in the USA

Drill/End Mills

Included Angle	Cutter Diameter*	Length of Cut	Flutes	Shank Diameter	Overall Length	Uncoated		AlTiN Coated	
						Tool #	Price	Tool #	Price
$A \begin{smallmatrix} +1^\circ \\ -1^\circ \end{smallmatrix}$	D1	$L2 \begin{smallmatrix} +.030'' \\ -.000'' \\ +.76 \text{ mm} \\ -.00 \text{ mm} \end{smallmatrix}$		D2 (h6)	L1				
90°	3 mm	8 mm	2	3 mm	38 mm	DMM-030-290	16.20	DMM-030-290X	18.70
	3 mm	8 mm	4	3 mm	38 mm	DMM-030-490	17.00	DMM-030-490X	19.50
	.1250	.500	2	.1250	1.5	DM-125-290	16.20	DM-125-290X	18.70
	.1250	.500	4	.1250	1.5	DM-125-490	17.00	DM-125-490X	19.50
	4 mm	11 mm	2	4 mm	50 mm	DMM-040-290	22.70	DMM-040-290X	25.60
	4 mm	11 mm	4	4 mm	50 mm	DMM-040-490	23.65	DMM-040-490X	26.55
	.1875	.625	2	.1875	2.0	DM-187-290	22.70	DM-187-290X	25.60
	.1875	.625	4	.1875	2.0	DM-187-490	23.75	DM-187-490X	26.65
	5 mm	13 mm	2	6 mm	57 mm	DMM-050-290	28.40	DMM-050-290X	33.30
	6 mm	16 mm	2	6 mm	57 mm	DMM-060-290	28.40	DMM-060-290X	33.30
	6 mm	16 mm	4	6 mm	57 mm	DMM-060-490	29.70	DMM-060-490X	34.60
	.2500	.750	2	.2500	2.5	DM-250-290	28.40	DM-250-290X	33.30
	.2500	.750	4	.2500	2.5	DM-250-490	29.70	DM-250-490X	34.60
	.3125	.813	2	.3125	2.5	DM-312-290	35.35	DM-312-290X	42.15
	.3125	.813	4	.3125	2.5	DM-312-490	37.15	DM-312-490X	43.95
	8 mm	22 mm	2	8 mm	63 mm	DMM-080-290	35.35	DMM-080-290X	42.15
	8 mm	22 mm	4	8 mm	63 mm	DMM-080-490	36.90	DMM-080-490X	43.70
	.3750	1.000	2	.3750	2.5	DM-375-290	44.30	DM-375-290X	51.10
	.3750	1.000	4	.3750	2.5	DM-375-490	46.65	DM-375-490X	53.45
	10 mm	25 mm	2	10 mm	72 mm	DMM-100-290	44.30	DMM-100-290X	51.10
	10 mm	25 mm	4	10 mm	72 mm	DMM-100-490	46.15	DMM-100-490X	52.95
	12 mm	30 mm	2	12 mm	83 mm	DMM-120-290	66.95	DMM-120-290X	77.25
	12 mm	30 mm	4	12 mm	83 mm	DMM-120-490	73.25		
	.5000	1.000	2	.5000	3.0	DM-500-290	66.95	DM-500-290X	75.15
.5000	1.000	4	.5000	3.0	DM-500-490	73.25	DM-500-490X	81.45	
.6250	1.250	2	.6250	3.5	DM-625-290	134.35	DM-625-290X	146.75	
.6250	1.250	4	.6250	3.5	DM-625-490	140.65	DM-625-490X	153.05	
.7500	1.500	2	.7500	4.0	DM-750-290	197.60	DM-750-290X	211.90	
.7500	1.500	4	.7500	4.0	DM-750-490	206.90	DM-750-490X	221.20	
20 mm	45 mm	2	20 mm	104 mm			DMM-200-490X	232.65	

\*.0005" / .013 mm max TIR. Tolerances for cutter diameters .125"-.250": .000" / -.002"; diameters .313"-.750": .000" / -.003".

Continued on next page

DM / DMM

Drill/End Mills  
2 & 4 Flute (cont.)

Continued from previous page

Included Angle	Cutter Diameter*	Length of Cut	Flutes	Shank Diameter	Overall Length	Uncoated		AlTiN Coated	
						Tool #	Price	Tool #	Price
A $\begin{matrix} +1^\circ \\ -1^\circ \end{matrix}$	D1	L2 $\begin{matrix} +.030'' \\ -.000'' \\ +.76 \text{ mm} \\ -.00 \text{ mm} \end{matrix}$		D2 (h6)	L1				
	3 mm	8 mm	2	3 mm	38 mm	DMM-030-2120	16.20	DMM-030-2120X	18.70
	3 mm	8 mm	4	3 mm	38 mm	DMM-030-4120	17.00	DMM-030-4120X	19.50
	.1250	.500	2	.1250	1.5			DM-125-2120X	18.70
	.1250	.500	4	.1250	1.5	DM-125-4120	17.00	DM-125-4120X	19.50
	4 mm	11 mm	2	4 mm	50 mm	DMM-040-2120	22.70	DMM-040-2120X	25.60
	4 mm	11 mm	4	4 mm	50 mm	DMM-040-4120	23.65	DMM-040-4120X	26.55
	.1875	.625	2	.1875	2.0	DM-187-2120	22.70	DM-187-2120X	25.60
	.1875	.625	4	.1875	2.0	DM-187-4120	23.75	DM-187-4120X	26.65
	5 mm	13 mm	2	6 mm	57 mm	DMM-050-2120	28.40	DMM-050-2120X	33.30
	5 mm	13 mm	4	6 mm	57 mm	DMM-050-4120	29.70		
	6 mm	16 mm	2	6 mm	57 mm	DMM-060-2120	28.40	DMM-060-2120X	33.30
	.2500	.750	2	.2500	2.5	DM-250-2120	28.40	DM-250-2120X	33.30
	.2500	.750	4	.2500	2.5	DM-250-4120	29.70	DM-250-4120X	34.60
	.3125	.813	2	.3125	2.5	DM-312-2120	35.35	DM-312-2120X	42.15
	.3125	.813	4	.3125	2.5	DM-312-4120	37.15	DM-312-4120X	43.95
	8 mm	22 mm	2	8 mm	63 mm	DMM-080-2120	35.35		
	8 mm	22 mm	4	8 mm	63 mm	DMM-080-4120	36.90	DMM-080-4120X	43.70
	.3750	1.000	2	.3750	2.5	DM-375-2120	44.30	DM-375-2120X	51.10
	.3750	1.000	4	.3750	2.5	DM-375-4120	46.65	DM-375-4120X	53.45
	10 mm	25 mm	2	10 mm	72 mm	DMM-100-2120	44.30		
	10 mm	25 mm	4	10 mm	72 mm	DMM-100-4120	46.15		
	.4375	1.000	4	.4375	2.5	DM-437-4120	62.95		
	.4375	1.000	4	.4375	2.5			DM-437-2120X	66.90
	12 mm	30 mm	2	12 mm	83 mm	DMM-120-2120	66.95	DMM-120-2120X	77.25
	.5000	1.000	2	.5000	3.0	DM-500-2120	66.95	DM-500-2120X	75.15
	.5000	1.000	4	.5000	3.0	DM-500-4120	73.25	DM-500-4120X	81.45
	.6250	1.250	2	.6250	3.5	DM-625-2120	134.35	DM-625-2120X	146.75
	.6250	1.250	4	.6250	3.5	DM-625-4120	140.65	DM-625-4120X	153.05
	16 mm	35 mm	2	16 mm	92 mm	DMM-160-2120	134.35		
	16 mm	35 mm	4	16 mm	92 mm	DMM-160-4120	140.30	DMM-160-4120X	152.70
	18 mm	45 mm	4	18 mm	92 mm			DMM-180-4120X	212.80
.7500	1.500	2	.7500	4.0	DM-750-2120	197.60	DM-750-2120X	211.90	
.7500	1.500	4	.7500	4.0	DM-750-4120	206.90	DM-750-4120X	221.20	

\* .0005" / .013 mm max TIR. Tolerances for cutter diameters .125"-.250": .000" / -.002"; diameters .313"-.750": .000" / -.003".

Drill/End Mills

# Chamfer Cutters

CS

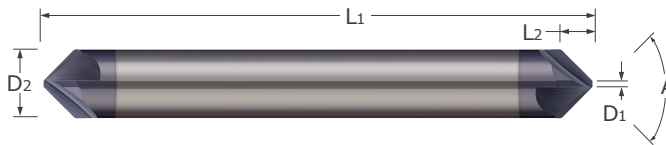

- Designed for chamfer milling, countersinking, and deburring
- Double-ended
- Available in 60°, 82°, 90°, 100°, and 120° included angles
- Tip Diameter (D<sub>1</sub>) is non-cutting
- Multi-tooth for greater metal removal rates
- AlTiN coating option for added lubricity and increased wear resistance in difficult-to-machine materials
- Solid carbide
- CNC ground in the USA

Chamfer Cutters

Included Angle	Tip Diameter	Length of Cut	Flutes	Shank Diameter	Overall Length	Uncoated		AlTiN Coated	
						Tool #	Price	Tool #	Price
A $+1^\circ$ $-1^\circ$	D <sub>1</sub> $+0.0001$ $-0.003$	L <sub>2</sub>		D <sub>2</sub> (h6)	L <sub>1</sub>				
60°	.030	.082	3	.1250	1.5	CS-125-060	23.95	CS-125-060X	27.65
	.040	.128	4	.1875	2.0			CS-187-060X	32.90
	.050	.173	6	.2500	2.5	CS-250-060	31.25	CS-250-060X	39.05
	.060	.219	6	.3125	2.5	CS-312-060	43.75	CS-312-060X	54.95
	.070	.264	6	.3750	2.5	CS-375-060	49.95	CS-375-060X	61.05
	.080	.364	6	.5000	3.0	CS-500-060	72.50	CS-500-060X	86.10
82°	.030	.055	3	.1250	1.5	CS-125-082	23.95	CS-125-082X	27.65
	.040	.085	4	.1875	2.0	CS-187-082	28.50	CS-187-082X	32.90
	.050	.115	6	.2500	2.5	CS-250-082	31.25	CS-250-082X	39.05
	.060	.145	6	.3125	2.5	CS-312-082	43.75	CS-312-082X	54.95
	.070	.175	6	.3750	2.5	CS-375-082	49.95	CS-375-082X	61.05
	.080	.242	6	.5000	3.0	CS-500-082	72.50	CS-500-082X	86.10
90°	.030	.047	3	.1250	1.5	CS-125-090	23.95	CS-125-090X	27.65
	.040	.074	4	.1875	2.0	CS-187-090	28.50	CS-187-090X	32.90
	.050	.100	6	.2500	2.5	CS-250-090	31.25	CS-250-090X	39.05
	.060	.126	6	.3125	2.5	CS-312-090	43.75	CS-312-090X	54.95
	.070	.152	6	.3750	2.5	CS-375-090	49.95	CS-375-090X	61.05
	.080	.210	6	.5000	3.0	CS-500-090	72.50	CS-500-090X	86.10
100°	.030	.040	3	.1250	1.5	CS-125-100	23.95	CS-125-100X	27.65
	.040	.062	4	.1875	2.0	CS-187-100	28.50	CS-187-100X	32.90
	.050	.084	6	.2500	2.5	CS-250-100	31.25	CS-250-100X	39.05
	.060	.106	6	.3125	2.5	CS-312-100	43.75	CS-312-100X	54.95
	.070	.128	6	.3750	2.5	CS-375-100	49.95	CS-375-100X	61.05
	.080	.176	6	.5000	3.0	CS-500-100	72.50	CS-500-100X	86.10
120°	.030	.027	3	.1250	1.5	CS-125-120	23.95	CS-125-120X	27.65
	.040	.043	4	.1875	2.0	CS-187-120	28.50	CS-187-120X	32.90
	.050	.058	6	.2500	2.5	CS-250-120	31.25	CS-250-120X	39.05
	.060	.073	6	.3125	2.5			CS-312-120X	54.95
	.070	.088	6	.3750	2.5			CS-375-120X	61.05
	.080	.121	6	.5000	3.0			CS-500-120X	86.10

MBC

**Chamfer Cutters**  
Back Chamfer Cutters

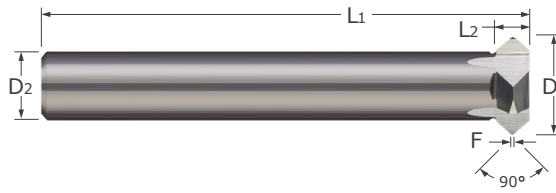

- 90° included angle for chamfer milling the top and bottom of a part
- Multiple flutes for improved finish and increased metal removal rates
- Cuts on angle only
- Solid carbide head brazed on a carbide shank
- CNC ground in the USA

Cutter Diameter	Cutter Width	Flat	Flutes	Shank Diameter	Overall Length	Uncoated	
						Tool #	Price
$D_1 \begin{smallmatrix} +.000'' \\ -.005'' \end{smallmatrix}$	$L_2 \begin{smallmatrix} +.000'' \\ -.015'' \end{smallmatrix}$	$F \begin{smallmatrix} +.000'' \\ -.005'' \end{smallmatrix}$		$D_2 \text{ (h6)}$	$L_1$		
.375	.125	.031	4	.2500	2.63	MBC-375	73.20
.500	.125	.031	5	.3125	2.63	MBC-500	89.20
.750	.156	.031	6	.3750	2.66	MBC-750	110.70
1.000	.188	.031	7	.5000	3.19	MBC-001	144.45

Chamfer Cutters

# Runner Cutters

MRF / MRT

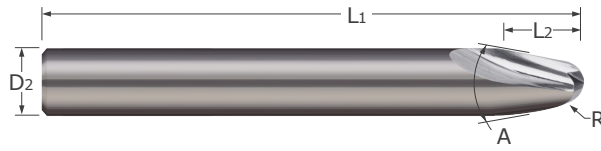

- Designed to mill 20° and 30° channels in molds
- 2 helical flutes
- Center cutting
- Solid carbide
- CNC ground in the USA

Runner Cutters

Included Angle	Radius	Length of Cut	Flutes	Shank Diameter	Overall Length	Uncoated	
						Tool #	Price
$A \begin{matrix} +1^\circ \\ -1^\circ \end{matrix}$	$R \begin{matrix} +.0030'' \\ -.0000'' \end{matrix}$	L2		D2 (h6)	L1		
20°	.0312	.383	2	.1875	2.0	MRT-187-031	38.10
	.0469	.308	2	.1875	2.0	MRT-187-046	38.10
	.0625	.414	2	.2500	2.5	MRT-250-062	42.25
	.0781	.338	2	.2500	2.5	MRT-250-078	42.25
	.0938	.437	2	.3125	2.5	MRT-312-093	51.35
	.1094	.366	2	.3125	2.5	MRT-312-109	51.35
	.1250	.468	2	.3750	2.5	MRT-375-125	54.00
	.1562	.675	2	.5000	3.0	MRT-500-156	67.80
30°	.0312	.262	2	.1875	2.0	MRF-187-031	38.10
	.0469	.216	2	.1875	2.0	MRF-187-046	38.10
	.0625	.287	2	.2500	2.5	MRF-250-062	42.25
	.0781	.243	2	.2500	2.5	MRF-250-078	42.25
	.1094	.270	2	.3125	2.5	MRF-312-109	51.35

RTC / RTCM / RSC  
RSCM / RNC / RNCM

Engraving Cutters  
Tipped Off – Single Ended

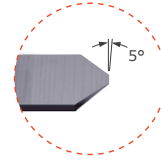
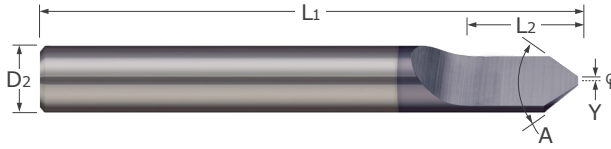

- Designed for engraving and v-grooving in various applications
- Tipped off end diameter for improved cutting
- Point offset (Y) represents half of flat generated in workpiece (Workpiece Flat = 2Y)
- Half round style
- Relieved for right hand milling
- AlTiN coating option for added lubricity and increased wear resistance in difficult-to-machine materials
- Solid carbide ■ CNC ground in the USA

Included Angle	Shank Diameter	Point Offset	Split Length	Overall Length	Uncoated		AlTiN Coated	
					Tool #	Price	Tool #	Price
A <sup>+0°30'</sup> -0°30'	D2 (h6)	Y +.001" -.001" +.02 mm -.02 mm	L2 +.015" -.015" +.38 mm -.38 mm	L1				
30°	3 mm	0.10 mm	7 mm	38 mm	RTCM-030-1	13.05	RTCM-030-1X	15.55
	.1250	.004	.375	1.5	RTC-125-1	17.90	RTC-125-1X	19.30
	.1250	.004	.375	3.0	RTC-125-13	18.40	RTC-125-13X	20.60
	4 mm	0.10 mm	10 mm	50 mm	RTCM-040-1	16.70	RTCM-040-1X	19.60
	.1875	.004	.437	2.0	RTC-187-1	22.20		
	5 mm	0.10 mm	12 mm	50 mm	RTCM-050-1	18.95		
	6 mm	0.10 mm	12 mm	57 mm	RTCM-060-1	20.15	RTCM-060-1X	25.05
	.2500	.004	.500	2.5	RTC-250-1	24.00	RTC-250-1X	34.70
	.2500	.004	.500	4.0	RTC-250-14	35.00		
	.2500	.010	.500	2.5	RTC-250-120	23.20	RTC-250-120X	34.70
	.2500	.015	.500	2.5	RTC-250-130	28.80		
	.2500	.022	.500	2.5	RTC-250-145	30.40		
	.2500	.030	.500	2.5	RTC-250-160	30.40		
	.3125	.004	.500	2.5	RTC-312-1	44.90		
	.3125	.004	.500	4.0	RTC-312-14	56.40		
	8 mm	0.10 mm	12 mm	63 mm	RTCM-080-1	32.35	RTCM-080-1X	39.15
.3750	.004	.500	2.5	RTC-375-1	56.20			
12 mm	0.10 mm	14 mm	83 mm			RTCM-120-1X	77.20	
.5000	.004	.625	3.0	RTC-500-1	87.90			
60°	3 mm	0.10 mm	5 mm	38 mm	RSCM-030-1	13.05	RSCM-030-1X	15.55
	.1250	.004	.375	1.5	RSC-125-1	17.60	RSC-125-1X	18.70
	.1250	.004	.375	3.0	RSC-125-13	18.80		
	4 mm	0.10 mm	6 mm	50 mm	RSCM-040-1	16.70	RSCM-040-1X	19.60
	.1875	.004	.375	2.0	RSC-187-1	21.50	RSC-187-1X	28.40
	.1875	.004	.375	3.0	RSC-187-13	22.90		
	5 mm	0.10 mm	7 mm	50 mm			RSCM-050-1X	22.85
	6 mm	0.10 mm	8 mm	57 mm	RSCM-060-1	20.15	RSCM-060-1X	25.05
	.2500	.004	.375	2.5	RSC-250-1	25.60		
	.2500	.004	.375	4.0	RSC-250-14	38.10		
	.2500	.010	.375	2.5	RSC-250-120	25.40	RSC-250-120X	34.70
	.2500	.015	.375	2.5	RSC-250-130	28.30		
	.2500	.022	.375	2.5	RSC-250-145	30.40		

Continued on next page

Engraving Cutters

# Engraving Cutters

## Tipped Off – Single Ended (cont.)

RTC / RTCM / RSC  
RSCM / RNC / RNCM

Continued from previous page

Included Angle	Shank Diameter	Point Offset	Split Length	Overall Length	Uncoated		AlTiN Coated	
					Tool #	Price	Tool #	Price
A $+0^{\circ}30'$ $-0^{\circ}30'$	D <sub>2</sub> (h6)	Y $+0.001"$ $-0.001"$ $+0.02$ mm $-0.02$ mm	L <sub>2</sub> $+0.015"$ $-0.015"$ $+0.38$ mm $-0.38$ mm	L <sub>1</sub>				
60°	.2500	.030	.375	2.5	RSC-250-160	30.40		
	.3125	.004	.500	2.5	RSC-312-1	44.70		
	.3125	.004	.500	4.0	RSC-312-14	56.40		
	8 mm	0.10 mm	10 mm	63 mm	RSCM-080-1	32.35	RSCM-080-1X	39.15
	.3750	.004	.500	2.5	RSC-375-1	55.10	RSC-375-1X	64.20
	.3750	.004	.500	4.0	RSC-375-14	79.70		
	10 mm	0.10 mm	12 mm	72 mm	RSCM-100-1	47.65	RSCM-100-1X	54.45
	12 mm	0.10 mm	14 mm	83 mm	RSCM-120-1	66.90	RSCM-120-1X	77.20
.5000	.004	.625	3.0	RSC-500-1	87.90	RSC-500-1X	93.00	
90°	3 mm	0.10 mm	5 mm	38 mm	RNCM-030-1	13.05	RNCM-030-1X	15.55
	.1250	.004	.375	1.5	RNC-125-1	16.60	RNC-125-1X	24.00
	.1250	.004	.375	3.0	RNC-125-13	21.70		
	4 mm	0.10 mm	6 mm	50 mm	RNCM-040-1	16.70	RNCM-040-1X	19.60
	.1875	.004	.375	2.0	RNC-187-1	23.30	RNC-187-1X	21.60
	.1875	.004	.375	3.0	RNC-187-13	24.30	RNC-187-13X	30.50
	5 mm	0.10 mm	7 mm	50 mm	RNCM-050-1	18.95	RNCM-050-1X	22.85
	6 mm	0.10 mm	8 mm	57 mm	RNCM-060-1	20.15	RNCM-060-1X	25.05
	.2500	.004	.375	2.5	RNC-250-1	26.60	RNC-250-1X	27.80
	.2500	.004	.375	4.0	RNC-250-14	32.30	RNC-250-14X	42.80
	.2500	.015	.375	2.5	RNC-250-130	30.40		
	.2500	.022	.375	2.5	RNC-250-145	30.40		
	.2500	.030	.375	2.5	RNC-250-160	30.40		
	.3125	.004	.500	2.5	RNC-312-1	36.20		
	8 mm	0.10 mm	10 mm	63 mm	RNCM-080-1	32.35	RNCM-080-1X	39.15
	.3750	.004	.500	2.5	RNC-375-1	52.90	RNC-375-1X	64.20
	10 mm	0.10 mm	12 mm	72 mm	RNCM-100-1	47.65		
	12 mm	0.10 mm	14 mm	83 mm	RNCM-120-1	66.90	RNCM-120-1X	77.20
.5000	.004	.625	3.0	RNC-500-1	85.60			



**RTC / RTCM / RSC  
RSCM / RNC / RNCM**

**Engraving Cutters**  
Tipped Off – Doubled Ended

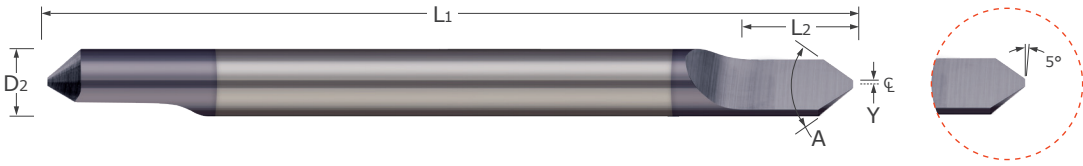

- Designed for engraving and v-grooving in various applications
- Tipped off end diameter for improved cutting
- Point offset (Y) represents half of flat generated in workpiece (Workpiece Flat = 2Y)
- Double ended
- Half round drill style
- Relieved for right hand milling
- AlTiN coating option for added lubricity and increased wear resistance in difficult-to-machine materials
- Solid carbide ■ CNC ground in the USA

Included Angle	Shank Diameter	Point Offset	Split Length	Overall Length	Uncoated		AITIN Coated	
					Tool #	Price	Tool #	Price
A <sup>+0°30'</sup> -0°30'	D2 (h6)	Y <sup>+ .001"</sup> <sup>- .001"</sup> <sup>+ .02 mm</sup> <sup>- .02 mm</sup>	L2 <sup>+ .015"</sup> <sup>- .015"</sup> <sup>+ .38 mm</sup> <sup>- .38 mm</sup>	L1				
<b>30°</b>	3 mm	0.10 mm	7 mm	38 mm	RTCM-030-2	17.45	RTCM-030-2X	21.05
	.1250	.004	.375	2.0	RTC-125-2	21.00	RTC-125-2X	29.50
	.1250	.004	.375	3.0	RTC-125-23	26.20	RTC-125-23X	34.30
	4 mm	0.10 mm	10 mm	50 mm	RTCM-040-2	22.25	RTCM-040-2X	26.55
	.1875	.004	.437	2.0	RTC-187-2	27.60	RTC-187-2X	35.80
	.1875	.004	.437	3.0	RTC-187-23	31.90	RTC-187-23X	42.00
	5 mm	0.10 mm	12 mm	50 mm	RTCM-050-2	25.10	RTCM-050-2X	29.40
	6 mm	0.10 mm	12 mm	57 mm	RTCM-060-2	27.45	RTCM-060-2X	35.25
	.2500	.004	.500	2.5	RTC-250-2	32.20	RTC-250-2X	41.00
	.2500	.004	.500	4.0	RTC-250-24	44.70		
	.2500	.010	.500	2.5	RTC-250-220	34.00	RTC-250-220X	41.70
	.2500	.015	.500	2.5	RTC-250-230	29.70		
	.2500	.022	.500	2.5	RTC-250-245	38.00	RTC-250-245X	45.50
	.2500	.030	.500	2.5	RTC-250-260	38.00		
	.3125	.004	.500	2.5	RTC-312-2	56.40		
	.3125	.004	.500	4.0	RTC-312-24	68.70		
8 mm	0.10 mm	12 mm	63 mm	RTCM-080-2	43.45	RTCM-080-2X	54.65	
.3750	.004	.500	2.5	RTC-375-2	70.00			
.3750	.004	.500	4.0	RTC-375-24	88.60			
10 mm	0.10 mm	12 mm	72 mm	RTCM-100-2	62.10			
.5000	.004	.625	3.0	RTC-500-2	96.10			
<b>60°</b>	2 mm	0.10 mm	4 mm	38 mm			RSCM-020-2X	18.90
	3 mm	0.10 mm	5 mm	38 mm	RSCM-030-2	17.45	RSCM-030-2X	21.05
	.1250	.004	.375	2.0	RSC-125-2	21.90	RSC-125-2X	26.10
	.1250	.004	.375	3.0	RSC-125-23	26.00		
	4 mm	0.10 mm	6 mm	50 mm	RSCM-040-2	22.25	RSCM-040-2X	26.55
	.1875	.004	.375	2.0	RSC-187-2	26.60	RSC-187-2X	31.30
	.1875	.004	.375	3.0	RSC-187-23	33.10		
	5 mm	0.10 mm	7 mm	50 mm			RSCM-050-2X	28.45
	6 mm	0.10 mm	8 mm	57 mm	RSCM-060-2	27.45	RSCM-060-2X	35.25
	.2500	.004	.375	2.5	RSC-250-2	33.40	RSC-250-2X	43.80

Continued on next page

Engraving Cutters

# Engraving Cutters

Tipped Off – Doubled Ended (cont.)

RTC / RTCM / RSC  
RSCM / RNC / RNCM

Continued from previous page

Included Angle	Shank Diameter	Point Offset	Split Length	Overall Length	Uncoated		AITIN Coated	
					Tool #	Price	Tool #	Price
A $+0^{\circ}30'$ $-0^{\circ}30'$	D <sub>2</sub> (h6)	Y $+0.001"$ $-0.001"$ $+0.02$ mm $-0.02$ mm	L <sub>2</sub> $+0.015"$ $-0.015"$ $+0.38$ mm $-0.38$ mm	L <sub>1</sub>				
60°	.2500	.004	.375	4.0	RSC-250-24	48.70		
	.2500	.010	.375	2.5	RSC-250-220	33.70	RSC-250-220X	43.80
	.2500	.015	.375	2.5	RSC-250-230	34.50		
	.2500	.030	.375	2.5	RSC-250-260	38.00		
	.3125	.004	.500	2.5	RSC-312-2	57.70	RSC-312-2X	60.60
	.3125	.004	.500	4.0	RSC-312-24	68.70		
	.3750	.004	.500	2.5	RSC-375-2	67.10	RSC-375-2X	83.30
	.3750	.004	.500	4.0	RSC-375-24	88.00		
	10 mm	0.10 mm	12 mm	72 mm	RSCM-100-2	62.10	RSCM-100-2X	73.30
	12 mm	0.10 mm	14 mm	83 mm	RSCM-120-2	84.40		
.5000	.004	.625	3.0	RSC-500-2	103.10			
90°	3 mm	0.10 mm	5 mm	38 mm	RNCM-030-2	17.45	RNCM-030-2X	21.05
	.1250	.004	.375	2.0	RNC-125-2	22.20	RNC-125-2X	31.30
	.1250	.004	.375	3.0	RNC-125-23	27.10	RNC-125-23X	35.30
	4 mm	0.10 mm	6 mm	50 mm	RNCM-040-2	22.25	RNCM-040-2X	26.55
	.1875	.004	.375	2.0	RNC-187-2	27.50	RNC-187-2X	32.60
	.1875	.004	.375	3.0	RNC-187-23	32.40		
	5 mm	0.10 mm	7 mm	50 mm	RNCM-050-2	25.10		
	6 mm	0.10 mm	8 mm	57 mm	RNCM-060-2	27.45	RNCM-060-2X	35.25
	.2500	.004	.375	2.5	RNC-250-2	34.10	RNC-250-2X	41.80
	.2500	.004	.375	4.0	RNC-250-24	44.70	RNC-250-24X	57.70
	.2500	.010	.375	2.5	RNC-250-220	33.80	RNC-250-220X	45.50
	.2500	.015	.375	2.5	RNC-250-230	35.30	RNC-250-230X	45.50
	.2500	.030	.375	2.5	RNC-250-260	38.00		
	.3125	.004	.500	2.5	RNC-312-2	55.00		
	.3125	0.004	.500	4.0	RNC-312-24	68.70	RNC-312-24X	83.90
	8 mm	0.10 mm	10 mm	63 mm	RNCM-080-2	43.45	RNCM-080-2X	54.65
	.3750	.004	.500	2.5	RNC-375-2	69.50	RNC-375-2X	83.30
	.3750	.004	.500	4.0	RNC-375-24	86.60		
	.5000	.004	.625	3.0	RNC-500-2	100.90	RNC-500-2X	116.60
	.5000	.004	.625	4.0	RNC-500-24	144.90		

Engraving Cutters

KC

Keyseat Cutters  
Square

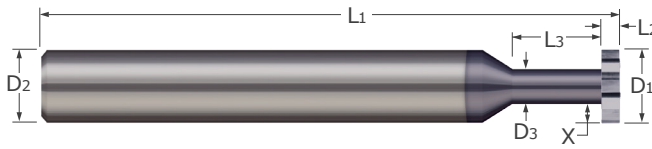

- Keyseat cutters down to .093" diameter
- Both sides of cutter are dished for clearance
- Standard and long length styles
- AlTiN coating option for added lubricity and increased wear resistance in difficult-to-machine materials
- Solid carbide ■ CNC ground in the USA

Cutter Diameter	Cutter Width	Neck Diameter	Radial Depth of Cut	Neck Length	Flutes	Shank Diameter	Overall Length	Uncoated		AlTiN Coated	
								Tool #	Price	Tool #	Price
$D_1 \begin{smallmatrix} +.0000" \\ -.0020" \end{smallmatrix}$	$L_2 \begin{smallmatrix} +.001" \\ -.000" \end{smallmatrix}$	$D_3 \begin{smallmatrix} +.000" \\ -.002" \end{smallmatrix}$	X	$L_3 \begin{smallmatrix} +.010" \\ -.000" \end{smallmatrix}$		D <sub>2</sub> (h6)	L <sub>1</sub>				
.0938	.010	.047	.019	.140	4	.1250	1.5	KC-093-140-010	38.35	KC-093-140-010X	40.85
.0938	.015	.047	.019	.140	4	.1250	1.5	KC-093-140-015	36.25	KC-093-140-015X	38.75
.0938	.020	.047	.019	.140	4	.1250	1.5	KC-093-140-020	36.25	KC-093-140-020X	38.75
.0938	.040	.047	.019	.140	4	.1250	1.5	KC-093-140-040	36.25	KC-093-140-040X	38.75
.1250	.010	.062	.028	.190	6	.1250	1.5			KC-125-190-010X	40.85
.1250	.015	.062	.028	.190	6	.1250	1.5	KC-125-190-015	36.25	KC-125-190-015X	38.75
.1250	.020	.062	.028	.190	6	.1250	1.5	KC-125-190-020	36.25	KC-125-190-020X	38.75
.1250	.025	.062	.028	.190	6	.1250	1.5	KC-125-190-025	36.25	KC-125-190-025X	38.75
.1250	.030	.062	.028	.190	6	.1250	1.5	KC-125-190-030	36.25	KC-125-190-030X	38.75
.1250	.030	.062	.028	.375	6	.1250	1.5	KC-125-375-030	36.25	KC-125-375-030X	38.75
.1250	.035	.062	.028	.190	6	.1250	1.5	KC-125-190-035	36.25	KC-125-190-035X	38.75
.1250	.040	.062	.028	.190	6	.1250	1.5	KC-125-190-040	36.25	KC-125-190-040X	38.75
.1250	.045	.062	.028	.190	6	.1250	1.5	KC-125-190-045	36.25	KC-125-190-045X	38.75
.1250	.050	.062	.028	.190	6	.1250	1.5	KC-125-190-050	36.25	KC-125-190-050X	38.75
.1250	.055	.062	.028	.190	6	.1250	1.5	KC-125-190-055	36.25	KC-125-190-055X	38.75
.1250	.060	.062	.028	.190	6	.1250	1.5	KC-125-190-060	36.25	KC-125-190-060X	38.75
.1250	.062	.062	.028	.190	6	.1250	1.5	KC-125-190-062	36.25	KC-125-190-062X	38.75
.1250	.062	.062	.028	.375	6	.1250	1.5	KC-125-375-062	36.25	KC-125-375-062X	38.75
.1250	.093	.062	.028	.190	6	.1250	1.5	KC-125-190-093	36.25	KC-125-190-093X	38.75
.1250	.093	.062	.028	.375	6	.1250	1.5	KC-125-375-093	36.25		
.1875	.010	.090	.045	.300	6	.1875	2.0	KC-187-300-010	40.45		
.1875	.015	.090	.045	.300	6	.1875	2.0	KC-187-300-015	38.35	KC-187-300-015X	41.25
.1875	.018	.090	.045	.300	6	.1875	2.0			KC-187-300-018X	41.25
.1875	.020	.090	.045	.300	6	.1875	2.0	KC-187-300-020	38.35	KC-187-300-020X	41.25
.1875	.025	.090	.045	.300	6	.1875	2.0	KC-187-300-025	38.35		
.1875	.029	.090	.045	.300	6	.1875	2.0	KC-187-300-029	38.35	KC-187-300-029X	41.25
.1875	.030	.090	.045	.300	6	.1875	2.0	KC-187-300-030	38.35	KC-187-300-030X	41.25
.1875	.035	.090	.045	.550	6	.1875	2.0	KC-187-550-035	38.35	KC-187-550-035X	41.25
.1875	.040	.090	.045	.300	6	.1875	2.0	KC-187-300-040	38.35	KC-187-300-040X	41.25
.1875	.045	.090	.045	.300	6	.1875	2.0			KC-187-300-045X	41.25

Continued on next page

Keyseat Cutters

# Keyseat Cutters

## Square (cont.)

KC

Continued from previous page

Cutter Diameter	Cutter Width	Neck Diameter	Radial Depth of Cut	Neck Length	Flutes	Shank Diameter	Overall Length	Uncoated		AlTiN Coated	
								Tool #	Price	Tool #	Price
D1 $\begin{smallmatrix} +.000" \\ -.002" \end{smallmatrix}$	L2 $\begin{smallmatrix} +.001" \\ -.000" \end{smallmatrix}$	D3 $\begin{smallmatrix} +.000" \\ -.002" \end{smallmatrix}$	X	L3 $\begin{smallmatrix} +.010" \\ -.000" \end{smallmatrix}$		D2 (h6)	L1				
.1875	.050	.090	.045	.300	6	.1875	2.0	KC-187-300-050	38.35	KC-187-300-050X	41.25
.1875	.055	.090	.045	.300	6	.1875	2.0			KC-187-300-055X	41.25
.1875	.060	.090	.045	.300	6	.1875	2.0	KC-187-300-060	38.35	KC-187-300-060X	41.25
.1875	.062	.090	.045	.550	6	.1875	2.0	KC-187-550-062	45.95	KC-187-550-062X	48.85
.1875	.093	.090	.045	.300	6	.1875	2.0	KC-187-300-093	38.35		
.1875	.093	.090	.045	.550	6	.1875	2.0	KC-187-550-093	38.35	KC-187-550-093X	41.25
.1875	.125	.090	.045	.300	6	.1875	2.0	KC-187-300-125	38.35		
.1875	.125	.090	.045	.550	6	.1875	2.0	KC-187-550-125	38.35	KC-187-550-125X	41.25
.2500	.030	.125	.059	.375	6	.2500	2.5			KC-250-375-030X	43.65
.2500	.030	.125	.059	.750	6	.2500	2.5			KC-250-750-030X	51.55
.2500	.035	.125	.059	.375	6	.2500	2.5			KC-250-375-035X	43.65
.2500	.040	.125	.059	.375	6	.2500	2.5	KC-250-375-040	40.70	KC-250-375-040X	43.65
.2500	.045	.125	.059	.375	6	.2500	2.5	KC-250-375-045	40.70		
.2500	.050	.125	.059	.375	6	.2500	2.5	KC-250-375-050	40.70		
.2500	.055	.125	.059	.375	6	.2500	2.5	KC-250-375-055	40.70		
.2500	.060	.125	.059	.375	6	.2500	2.5	KC-250-375-060	40.70	KC-250-375-060X	43.65
.2500	.062	.125	.059	.375	6	.2500	2.5	KC-250-375-062	40.70	KC-250-375-062X	43.65
.2500	.062	.125	.059	.750	6	.2500	2.5			KC-250-750-062X	43.65
.2500	.093	.125	.059	.375	6	.2500	2.5	KC-250-375-093	40.70	KC-250-375-093X	43.65
.2500	.093	.125	.059	.750	6	.2500	2.5	KC-250-750-093	40.70		
.2500	.125	.125	.059	.375	6	.2500	2.5	KC-250-375-125	40.70		
.2500	.125	.125	.059	.750	6	.2500	2.5	KC-250-750-125	40.70		
.3750	.020	.190	.089	.600	8	.3750	2.5			KC-375-600-020X	66.15
.3750	.030	.190	.089	.600	8	.3750	2.5	KC-375-600-030	59.35		
.3750	.035	.190	.089	.600	8	.3750	2.5	KC-375-600-035	59.35		
.3750	.040	.190	.089	.600	8	.3750	2.5	KC-375-600-040	59.35	KC-375-600-040X	66.15
.3750	.060	.190	.089	.600	8	.3750	2.5	KC-375-600-060	59.35	KC-375-600-060X	66.15
.3750	.062	.190	.089	1.125	8	.3750	2.5	KC-375-1125-062	65.65	KC-375-1125-062X	72.45
.3750	.068	.190	.089	.600	8	.3750	2.5	KC-375-600-068	59.35	KC-375-600-068X	66.15
.3750	.080	.190	.089	.600	8	.3750	2.5				
.3750	.086	.190	.089	.600	8	.3750	2.5	KC-375-600-086	59.35	KC-375-600-086X	66.15
.3750	.093	.190	.089	.600	8	.3750	2.5	KC-375-600-093	59.35	KC-375-600-093X	66.15
.3750	.093	.190	.089	1.125	8	.3750	2.5	KC-375-1125-093	59.35	KC-375-1125-093X	66.15
.3750	.125	.190	.089	.600	8	.3750	2.5	KC-375-600-125	59.35	KC-375-600-125X	66.15
.3750	.125	.190	.089	1.125	8	.3750	2.5	KC-375-1125-125	59.35	KC-375-1125-125X	66.15
.3750	.156	.190	.089	.600	8	.3750	2.5	KC-375-600-156	59.35	KC-375-600-156X	66.15
.3750	.156	.190	.089	1.125	8	.3750	2.5	KC-375-1125-156	59.35	KC-375-1125-156X	66.15
.3750	.187	.190	.089	.600	8	.3750	2.5	KC-375-600-187	59.35		
.3750	.187	.190	.089	1.125	8	.3750	2.5	KC-375-1125-187	59.35	KC-375-1125-187X	66.15

Continued on next page

Keyseat Cutters

## KC

# Keyseat Cutters

## Square (cont.)

Continued from previous page

Cutter Diameter	Cutter Width	Neck Diameter	Radial Depth of Cut	Neck Length	Flutes	Shank Diameter	Overall Length	Uncoated		AlTiN Coated	
								Tool #	Price	Tool #	Price
D1 $^{+.000''}_{-.002''}$	L2 $^{+.001''}_{-.000''}$	D3 $^{+.000''}_{-.002''}$	X	L3 $^{+.010''}_{-.000''}$		D2 (h6)	L1				
.5000	.030	.250	.121	.750	8	.5000	3.0	KC-500-750-030	76.60		
.5000	.035	.250	.121	.750	8	.5000	3.0	KC-500-750-035	76.60	KC-500-750-035X	84.80
.5000	.040	.250	.121	.750	8	.5000	3.0	KC-500-750-040	76.60	KC-500-750-040X	84.80
.5000	.060	.250	.121	.750	8	.5000	3.0			KC-500-750-060X	84.80
.5000	.062	.250	.121	.750	8	.5000	3.0	KC-500-750-062	76.60		
.5000	.062	.250	.121	1.500	8	.5000	3.0	KC-500-1500-062	86.65	KC-500-1500-062X	94.85
.5000	.093	.250	.121	.750	8	.5000	3.0	KC-500-750-093	76.60	KC-500-750-093X	84.80
.5000	.093	.250	.121	1.500	8	.5000	3.0	KC-500-1500-093	86.65	KC-500-1500-093X	94.85
.5000	.103	.250	.121	.750	8	.5000	3.0	KC-500-750-103	76.60	KC-500-750-103X	84.80
.5000	.118	.250	.121	.750	8	.5000	3.0	KC-500-750-118	76.60	KC-500-750-118X	84.80
.5000	.118	.250	.121	1.500	8	.5000	3.0	KC-500-1500-118	86.65		
.5000	.120	.250	.121	.750	8	.5000	3.0	KC-500-750-120	76.60	KC-500-750-120X	84.80
.5000	.125	.250	.121	.750	8	.5000	3.0	KC-500-750-125	76.60	KC-500-750-125X	84.80
.5000	.125	.250	.121	1.500	8	.5000	3.0	KC-500-1500-125	86.65	KC-500-1500-125X	94.85
.5000	.156	.250	.121	.750	8	.5000	3.0	KC-500-750-156	76.60		
.5000	.156	.250	.121	1.500	8	.5000	3.0	KC-500-1500-156	86.65	KC-500-1500-156X	94.85
.5000	.187	.250	.121	.750	8	.5000	3.0	KC-500-750-187	76.60	KC-500-750-187X	84.80
.5000	.187	.250	.121	1.500	8	.5000	3.0	KC-500-1500-187	86.65	KC-500-1500-187X	94.85
.5000	.250	.250	.121	.750	8	.5000	3.0	KC-500-750-250	76.60	KC-500-750-250X	84.80
.5000	.250	.250	.121	1.500	8	.5000	3.0	KC-500-1500-250	86.65	KC-500-1500-250X	94.85

# Corner Rounding End Mills

CREM

## 3 Flute – Single Ended

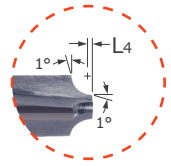
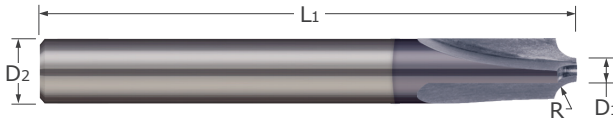

- Designed to mill corner radii into a part
- 1° max flares tangent at pilot and shoulder to avoid steps and burrs
- Cuts on radius only
- AlTiN coating option for added lubricity and increased wear resistance in difficult-to-machine materials
- Solid carbide ■ CNC ground in the USA

Minor Diameter	Radius	Max Lead in Length	Shank Diameter	Overall Length	Uncoated		AlTiN Coated	
					Tool #	Price	Tool #	Price
D1 $\begin{matrix} +.000 \text{ mm} \\ -.076 \text{ mm} \end{matrix}$	R $\begin{matrix} +.000 \text{ mm} \\ -.013 \text{ mm} \end{matrix}$	L4	D2 (h6)	L1				
1.5 mm	0.3 mm	.13 mm	6 mm	57 mm	CREM-060-030	37.00	CREM-060-030X	41.90
1.5 mm	0.5 mm	.13 mm	6 mm	57 mm			CREM-060-050X	41.90
1.5 mm	0.8 mm	.13 mm	6 mm	57 mm	CREM-060-080	37.00	CREM-060-080X	41.90
1.5 mm	1.0 mm	.13 mm	6 mm	57 mm	CREM-060-100	37.00	CREM-060-100X	41.90
1.5 mm	1.25 mm	.13 mm	6 mm	57 mm			CREM-060-125X	41.90
1.5 mm	1.5 mm	.13 mm	6 mm	57 mm	CREM-060-150	37.00	CREM-060-150X	41.90
1.5 mm	2.0 mm	.13 mm	6 mm	57 mm	CREM-060-200	37.00	CREM-060-200X	41.90
1.5 mm	2.5 mm	.13 mm	8 mm	63 mm			CREM-080-250X	51.30
1.5 mm	3.0 mm	.13 mm	8 mm	63 mm	CREM-080-300	44.50	CREM-080-300X	51.30
1.5 mm	4.0 mm	.13 mm	10 mm	73 mm	CREM-100-400	60.45	CREM-100-400X	67.25

CRE

Corner Rounding End Mills

3 Flute – Double Ended

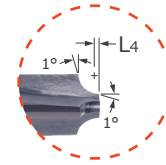
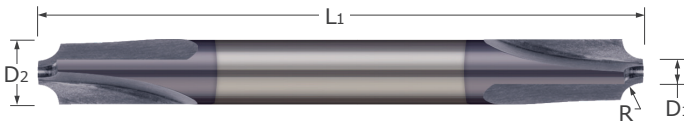

- Designed to mill corner radii into a part
- 1° max flares tangent at pilot and shoulder to avoid steps and burrs
- Cuts on radius only
- Double-ended
- AlTiN coating option for added lubricity and increased wear resistance in difficult-to-machine materials
- Solid carbide ■ CNC ground in the USA

Minor Diameter	Radius	Max Lead in Length	Shank Diameter	Overall Length	Uncoated		AlTiN Coated	
					Tool #	Price	Tool #	Price
D1 $^{+.000''}_{-.002''}$	R $^{+.0000''}_{-.0005''}$	L4	D2 (h6)	L1				
.060	.0100	.005	.1250	2.0	CRE-125-010	33.00	CRE-125-010X	36.60
.060	.0156	.005	.1250	2.0	CRE-125-015	33.00	CRE-125-015X	36.60
.060	.0200	.005	.1250	2.0	CRE-125-020	33.00	CRE-125-020X	36.60
.060	.0250	.005	.1250	2.0	CRE-125-025	33.00	CRE-125-025X	36.60
.060	.0300	.005	.1250	2.0	CRE-125-030	33.00	CRE-125-030X	36.60
.060	.0312	.005	.1250	2.0	CRE-125-031	33.00	CRE-125-031X	36.60
.060	.0350	.005	.1875	2.0	CRE-187-035	35.55	CRE-187-035X	39.95
.060	.0400	.005	.1875	2.0	CRE-187-040	35.55	CRE-187-040X	39.95
.060	.0450	.005	.1875	2.0	CRE-187-045	35.55	CRE-187-045X	39.95
.060	.0469	.005	.1875	2.0	CRE-187-047	35.55	CRE-187-047X	39.95
.060	.0500	.005	.1875	2.0	CRE-187-050	35.55	CRE-187-050X	39.95
.060	.0550	.005	.1875	2.0	CRE-187-055	35.55	CRE-187-055X	39.95
.060	.0600	.005	.1875	2.0	CRE-187-060	35.55	CRE-187-060X	39.95
.060	.0625	.005	.1875	2.0	CRE-187-062	35.55	CRE-187-062X	39.95

Minor Diameter	Radius	Max Lead in Length	Shank Diameter	Overall Length	Uncoated		AlTiN Coated	
					Tool #	Price	Tool #	Price
D1 $^{+.000''}_{-.003''}$	R $^{+.0000''}_{-.0005''}$	L4	D2 (h6)	L1				
.060	.0700	.005	.2500	2.5	CRE-250-070	46.05	CRE-250-070X	52.85
.060	.0750	.005	.2500	2.5	CRE-250-075	46.05	CRE-250-075X	52.85
.060	.0781	.005	.2500	2.5	CRE-250-078	46.05	CRE-250-078X	52.85
.060	.0800	.005	.2500	2.5	CRE-250-080	46.05	CRE-250-080X	52.85
.060	.0900	.005	.2500	2.5	CRE-250-090	46.05	CRE-250-090X	52.85
.060	.0938	.005	.2500	2.5	CRE-250-093	46.05	CRE-250-093X	52.85
.060	.1000	.005	.3125	2.5	CRE-312-100	55.60	CRE-312-100X	66.80
.060	.1094	.005	.3125	2.5	CRE-312-109	55.60	CRE-312-109X	66.80
.060	.1250	.005	.3125	2.5	CRE-312-125	55.60	CRE-312-125X	66.80
.060	.1406	.005	.3750	2.5	CRE-375-140	75.55	CRE-375-140X	86.65
.060	.1562	.005	.3750	2.5	CRE-375-156	75.55	CRE-375-156X	86.65
.120	.1718	.010	.5000	3.0	CRE-500-171	117.05	CRE-500-171X	129.55
.120	.1875	.010	.5000	3.0	CRE-500-187	117.05	CRE-500-187X	129.55
.120	.2031	.010	.6250	3.5	CRE-625-203	125.45	CRE-625-203X	145.55
.120	.2188	.010	.6250	3.5	CRE-625-218	125.45	CRE-625-218X	145.55
.120	.2344	.010	.6250	3.5	CRE-625-234	125.45	CRE-625-234X	145.55
.120	.2500	.010	.6250	3.5	CRE-625-250	125.45	CRE-625-250X	145.55
.120	.2812	.010	.7500	4.0	CRE-750-281	176.00		
.120	.3125	.010	.7500	4.0	CRE-750-312	176.00	CRE-750-312X	199.40
.120	.3750	.010	1.0000	4.0	CRE-001-375	328.35	CRE-001-375X	360.95
.120	.4370	.010	1.0000	4.0	CRE-001-437	328.35	CRE-001-437X	360.95

Corner Rounding End Mills

# Dovetail Cutters

DT

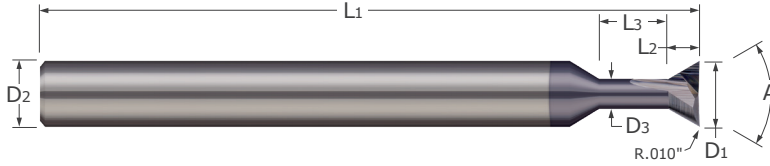

- Designed to mill dovetail grooves into a part
- Offered with 30°, 60°, and 90° included angles
- AlTiN coating option for added lubricity and increased wear resistance in difficult-to-machine materials
- Solid carbide
- CNC ground in the USA

Included Angle	Cutter Diameter*	Length of Cut	Neck Diameter	Neck Length	Corner Radius	Flutes	Shank Diameter	Overall Length	Uncoated		AlTiN Coated	
									Tool #	Price	Tool #	Price
A $+1^\circ$ $-1^\circ$	D1 $+0.0000''$ $-0.0020''$	L2	D3	L3 $+0.030''$ $-0.000''$	R		D2 (h6)	L1				
30°	.1250	.095	.080	.125	.010	2	.1250	1.5	DT-125-030-010	52.00	DT-125-030-010X	54.50
	.1875	.127	.125	.125	.010	2	.1875	2.0	DT-187-030-010	55.60	DT-187-030-010X	58.50
	.2500	.161	.170	.125	.010	2	.2500	2.5	DT-250-030-010	70.10	DT-250-030-010X	75.00
	.3125	.221	.200	.312	.010	2	.3125	2.5	DT-312-030-010	75.90	DT-312-030-010X	82.70
	.3750	.263	.240	.375	.010	3	.3750	2.5	DT-375-030-010	80.10	DT-375-030-010X	86.90
	.5000	.347	.320	.500	.010	3	.5000	3.0	DT-500-030-010	103.90	DT-500-030-010X	112.10
60°	.1250	.065	.065	.125	.010	2	.1250	1.5	DT-125-060-010	52.00	DT-125-060-010X	54.50
	.1875	.093	.095	.125	.010	2	.1875	2.0	DT-187-060-010	55.60	DT-187-060-010X	58.50
	.2500	.125	.120	.125	.010	2	.2500	2.5	DT-250-060-010	70.10	DT-250-060-010X	75.00
	.3125	.162	.140	.312	.010	2	.3125	2.5	DT-312-060-010	75.90	DT-312-060-010X	82.70
	.3750	.190	.170	.375	.010	3	.3750	2.5	DT-375-060-010	80.10	DT-375-060-010X	86.90
	.5000	.255	.220	.500	.010	3	.5000	3.0	DT-500-060-010	103.90	DT-500-060-010X	112.10
90°	.1250	.042	.070	.125	.010	2	.1250	1.5	DT-125-090-010	52.00	DT-125-090-010X	54.50
	.1875	.048	.120	.125	.010	2	.1875	2.0	DT-187-090-010	55.60	DT-187-090-010X	58.50
	.2500	.064	.150	.125	.010	2	.2500	2.5	DT-250-090-010	70.10	DT-250-090-010X	75.00
	.3125	.095	.150	.312	.010	2	.3125	2.5	DT-312-090-010	75.90	DT-312-090-010X	82.70
	.3750	.127	.150	.375	.010	3	.3750	2.5	DT-375-090-010	80.10	DT-375-090-010X	86.90
	.5000	.164	.200	.500	.010	3	.5000	3.0	DT-500-090-010	103.90	DT-500-090-010X	112.10

\* .0005" max TIR

Dovetail Cutters



DSC

Die Sink Cutters

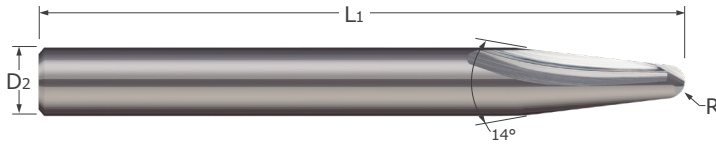

- Utilized for die sinking and finish milling operations
- 2 straight flutes
- 14° included angle with a radius end
- Solid carbide ■ CNC ground in the USA

Radius	Flutes	Shank Diameter	Overall Length	Uncoated	
				Tool #	Price
R $\begin{matrix} +.0030'' \\ -.0000'' \end{matrix}$		D <sub>2</sub> (h6)	L <sub>1</sub>		
.0400	2	.1562	2.0	DSC-156	30.50
.0700	2	.3125	2.5	DSC-312	50.40
.0930	2	.3750	2.5	DSC-375	58.60
.1250	2	.5000	3.0	DSC-500	93.30

# Indexable

## Milling – Tool Holders

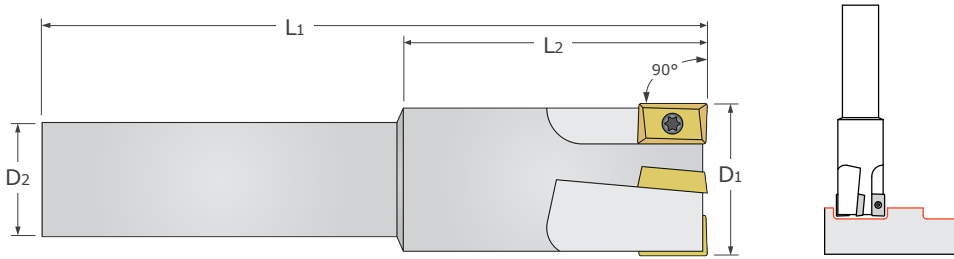

- 90° orientation angle allows for square shoulder cutting
- Utilizes ANSI standard APKT style inserts (not included)
- Each tool holder includes a M2.5 x T-8 torx screw and torx key (part # 16-1020)
- Non coolant-through
- Insert not included

Cutter Diameter	Body Length	Flutes	Shank Diameter	Overall Length	Insert Part Number	Holder Nomenclature	Tool Holder	
							Tool #	Price
D1	L2		D2	L1				
.375	1.500	1	.5000	3.0	50-2100	BAAP 1216 2	31-1216	105.75
.500	1.500	1	.5000	3.0	50-2100	BAAP 1616 2	31-1616	118.15
.625	1.500	2	.5000	3.0	50-2100	BAAP 1816 2	31-1816	130.60
.750	2.000	3	.7500	4.4	50-2100	BAAP 2424 2	31-2424	180.30
1.000	2.000	4	.7500	4.4	50-2100	BAAP 3224 2	31-3224	192.70
1.250	2.000	5	.7500	4.4	50-2100	BAAP 4024 2	31-4024	287.15

See pg 283 for indexable insert accessories

Indexable

Milling – Tool Holders – Coolant Through

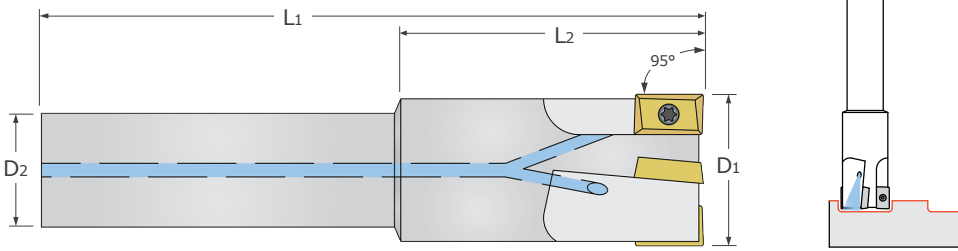

- Coolant-through milling tool holders designed to enhance chip evacuation
- 90° orientation angle allows for square shoulder cutting
- Utilizes ANSI standard APKT style inserts (not included)
- Each tool holder includes a M2.5 x T-8 torx screw and torx key (part # 16-1020)
- Insert not included

Cutter Diameter	Body Length	Flutes	Shank Diameter	Overall Length	Insert Part Number	Holder Nomenclature	Tool Holder	
							Tool #	Price
D <sub>1</sub>	L <sub>2</sub>		D <sub>2</sub>	L <sub>1</sub>				
.375	1.500	1	.5000	3.0	50-2100	AAAP 1216 2	30-1216	130.60
.500	1.500	1	.5000	3.0	50-2100	AAAP 1616 2	30-1616	142.95
.625	1.500	2	.5000	3.0	50-2100	AAAP 1816 2	30-1816	156.05
.750	2.000	3	.7500	4.4	50-2100	AAAP 2424 2	30-2424	183.80
1.000	2.000	4	.7500	4.4	50-2100	AAAP 3224 2	30-3224	294.60
1.250	2.000	5	.7500	4.4	50-2100	AAAP 4024 2	30-4024	315.75

See pg 283 for indexable insert accessories

See pg 282 for tool set options

# Drills

SPD

## Spotting & Centering Drill

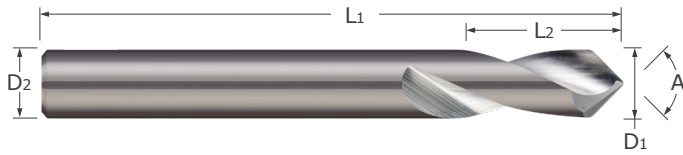

- Optimized for spotting and chamfering applications
- Available in 82°, 90°, 100°, and 120° included point angles
- Can be utilized for countersinking and chamfering existing holes
- Maximum drill depth not to exceed included angle
- Solid carbide ■ CNC ground in the USA
- Insert not included

Included Angle	Drill Diameter	Flute Length	Shank Diameter	Overall Length	Uncoated	
					Tool #	Price
$A \begin{smallmatrix} +1^\circ \\ -1^\circ \end{smallmatrix}$	$D1 \begin{smallmatrix} +.0000'' \\ -.0005'' \end{smallmatrix}$	$L2 \begin{smallmatrix} +.031'' \\ -.031'' \end{smallmatrix}$	D2 (h6)	L1		
82°	.2500	.750	.2500	2.5	SPD-250-082	22.90
	.3125	.750	.3125	2.5	SPD-312-082	26.70
	.3750	1.000	.3750	2.5	SPD-375-082	33.60
	.5000	1.000	.5000	2.5	SPD-500-082	50.05
	.6250	1.125	.6250	2.5	SPD-625-082	88.50
	.7500	1.125	.7500	2.5	SPD-750-082	134.25
90°	.2500	.750	.2500	2.5	SPD-250-090	22.90
	.3125	.750	.3125	2.5	SPD-312-090	26.70
	.3750	1.000	.3750	2.5	SPD-375-090	33.60
	.5000	1.000	.5000	2.5	SPD-500-090	50.05
	.6250	1.125	.6250	2.5	SPD-625-090	88.50
	.7500	1.125	.7500	2.5	SPD-750-090	134.25
	1.0000	1.250	1.0000	2.5	SPD-001-090	203.50
100°	.2500	.750	.2500	2.5	SPD-250-100	22.90
	.3125	.750	.3125	2.5	SPD-312-100	26.70
	.3750	1.000	.3750	2.5	SPD-375-100	33.60
	.5000	1.000	.5000	2.5	SPD-500-100	50.05
	.6250	1.125	.6250	2.5	SPD-625-100	88.50
	.7500	1.125	.7500	2.5	SPD-750-100	134.25
	1.0000	1.250	1.0000	2.5	SPD-001-100	203.50
120°	.2500	.750	.2500	2.5	SPD-250-120	22.90
	.3125	.750	.3125	2.5	SPD-312-120	26.70
	.3750	1.000	.3750	2.5	SPD-375-120	33.60
	.5000	1.000	.5000	2.5	SPD-500-120	50.05
	.6250	1.125	.6250	2.5	SPD-625-120	88.50
	.7500	1.125	.7500	2.5	SPD-750-120	134.25

SD

Drills  
Spade Drill

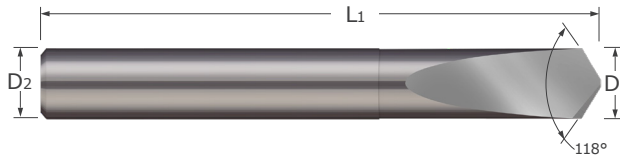

- Designed for drilling in hardened materials
- Excellent option when requiring holes free of retract marks in non-ferrous materials
- Solid carbide
- CNC ground in the USA

Drill Diameter	Web Thickness	Shank Diameter	Overall Length	Uncoated	
				Tool #	Price
$D_1^{+.0000''}$ $D_1^{-.0005''}$	$+.002''$ $-.002''$	D2 (h6)	L1		
.0312	.010	.0312	1.25	SD-031	12.85
.0625	.012	.0625	1.50	SD-062	13.35
.0937	.016	.0938	1.50	SD-093	13.70
.1250	.020	.1250	1.50	SD-125	15.05
.1562	.025	.1562	2.00	SD-156	16.50
.1875	.028	.1875	2.00	SD-187	19.15
.2188	.030	.2188	2.00	SD-218	22.55
.2500	.035	.2500	2.00	SD-250	25.85
.3125	.040	.3125	2.50	SD-312	35.75
.3750	.046	.3750	2.50	SD-375	43.10
.4375	.050	.4375	2.50	SD-437	49.40
.5000	.060	.5000	2.50	SD-500	60.30

# Drills

DR

## Jobber Length Drills

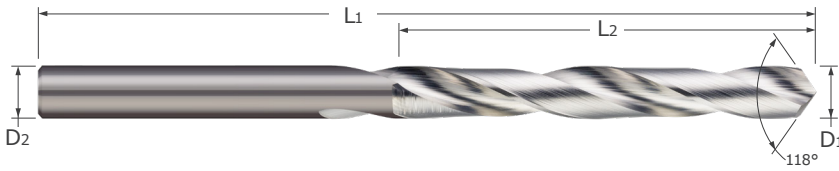

- 118° included point jobber drills can be used for general purpose drilling
- Solid carbide
- CNC ground in the USA

Drill Diameter	Flute Length	Shank Diameter	Overall Length	Uncoated	
				Tool #	Price
$D_1 \begin{matrix} +.0000'' \\ -.0005'' \end{matrix}$	$L_2 \begin{matrix} +.062'' \\ -.062'' \end{matrix}$	$D_2 \text{ (h6)}$	$L_1$		
.0312	.500	.0312	1.25	DR-031-2	11.55
.0469	.750	.0469	1.50	DR-046-2	15.20
.0625	.750	.0625	1.50	DR-062-2	15.50
.0781	.875	.0781	1.75	DR-078-2	16.40
.0938	1.000	.0938	2.00	DR-093-2	18.00
.1094	1.250	.1094	2.25	DR-109-2	19.75
.1250	1.250	.1250	2.25	DR-125-2	20.85
.1875	1.625	.1875	2.75	DR-187-2	30.65
.2500	2.000	.2500	3.25	DR-250-2	45.50
.3125	2.375	.3125	3.75	DR-312-2	60.45

DC / DCM

Combined Drill & Countersinks

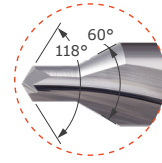
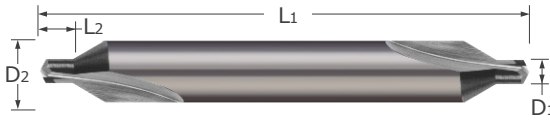

- Designed for predrilling 60° live center holes
- Can be utilized for countersinking and spot drilling
- Double-ended for quicker tool changes
- Solid carbide ■ CNC ground in the USA

Drill Diameter			Drill Length	Shank Diameter	Overall Length	Uncoated	
D1			L2	D2 (h6)	L1	Tool #	Price
+ .0030" - .0000"	+ .08 mm - .00 mm	decimal equiv.					
	0.5 mm	.0200	0.8 mm	3.15 mm	35 mm	DCM-005	21.60
.0250		.0250	.031	.1250	1.500	DC-00	22.45
.0312		.0312	.038	.1250	1.500	DC-01	22.45
	0.8 mm	.0320	1.1 mm	3.15 mm	35 mm	DCM-008	21.60
	1.0 mm	.0390	1.3 mm	3.15 mm	35 mm	DCM-010	21.60
.0469		.0469	.047	.1250	1.500	DC-1	22.45
	1.25 mm	.0490	1.6 mm	3.15 mm	35 mm	DCM-013	21.60
	1.6 mm	.0630	2.0 mm	4 mm	35.5 mm	DCM-016	31.65
.0781		.0781	.078	.1875	1.875	DC-2	35.35
	2.5 mm	.0980	3.1 mm	6.3 mm	45 mm	DCM-025	37.95
.1094		.1094	.109	.2500	2.000	DC-3	39.55
	3.15 mm	.1240	3.9 mm	8 mm	50 mm	DCM-032	50.75
.1250		.1250	.125	.3125	2.125	DC-4	52.85
.1875		.1875	.188	.4375	2.750	DC-5	79.60
.2188		.2188	.219	.5000	3.000	DC-6	101.95

See pg 282 for tool set options

# Thread Milling Cutters

## Single Form – UN Threads

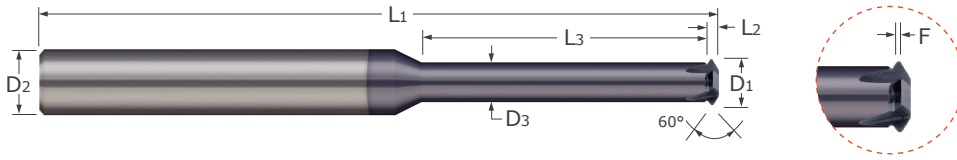

- Mills internal and external 60° UN threads
- Single thread form designed to mill common pitch sizes
- Single form design reduces tool pressure for deep thread milling applications
- Mills right hand and left hand threads
- AlTiN coating option for added lubricity and increased wear resistance in difficult-to-machine materials
- Solid carbide ■ CNC ground in the USA

Threads Per Inch	Cutter Diameter	Neck Length	Neck Diameter	Flat	Cutter Width	Flutes	Shank Diameter	Overall Length	Uncoated		AlTiN Coated	
									Tool #	Price	Tool #	Price
TPI	$D_1^{+.0000}_{-.0050}$	$L_3^{+.0150}_{-.0000}$	$D_3$	$F^{+.0010}_{-.0000}$	$L_2$		$D_2$ (h6)	$L_1$	Tool #	Price	Tool #	Price
56 - 80	.060	.250	.030	SHARP	.017	2	.1250	1.5	TM-060-4	57.55	TM-060-4X	60.05
56 - 80	.060	.375	.030	SHARP	.017	2	.1250	1.5	TM-060-6	57.55	TM-060-6X	60.05
40 - 64	.080	.250	.035	SHARP	.026	2	.1250	1.5	TM-080-4	54.00	TM-080-4X	56.50
40 - 64	.080	.500	.035	SHARP	.026	2	.1250	1.5	TM-080-8	54.00	TM-080-8X	56.50
32 - 64	.100	.375	.050	SHARP	.029	2	.1250	1.5	TM-100-6	46.65	TM-100-6X	49.15
32 - 64	.100	.500	.050	SHARP	.029	2	.1250	1.5	TM-100-8	46.65		
32 - 64	.100	.625	.050	SHARP	.029	2	.1250	2.0	TM-100-10	46.65	TM-100-10X	49.15
32 - 56	.120	.375	.070	.0010	.030	3	.1875	2.0	TM-120-6	55.10	TM-120-6X	58.00
32 - 56	.120	.500	.070	.0010	.030	3	.1875	2.0	TM-120-8	55.10	TM-120-8X	58.00
32 - 56	.120	.625	.070	.0010	.030	3	.1875	2.0	TM-120-10	55.10	TM-120-10X	58.00
24 - 56	.140	.500	.075	.0010	.038	3	.1875	2.0	TM-140-8	55.10	TM-140-8X	58.00
24 - 56	.140	.750	.075	.0010	.038	3	.1875	2.0	TM-140-12	55.10	TM-140-12X	58.00
18 - 56	.180	.500	.090	.0015	.055	4	.2500	2.5	TM-180-8	64.80	TM-180-8X	69.70
18 - 56	.180	.750	.090	.0015	.055	4	.2500	2.5	TM-180-12	64.80	TM-180-12X	69.70
18 - 56	.180	1.000	.090	.0015	.055	4	.2500	2.5	TM-180-16	64.80	TM-180-16X	69.70
16 - 48	.240	1.500	.150	.0015	.055	4	.3125	3.5	TM-250-24	72.35	TM-250-24X	80.85
14 - 48	.250	1.000	.100	.0015	.065	4	.2500	2.5	TM-250-16	64.80	TM-250-16X	69.70
16 - 48	.250	1.125	.150	.0015	.060	4	.2500	2.5	TM-250-18	64.80	TM-250-18X	69.70
14 - 40	.290	1.000	.170	.0020	.071	4	.3750	4.0	TM-290-16	80.45	TM-290-16X	88.85
12 - 32	.360	1.000	.210	.0020	.085	4	.3750	4.0	TM-360-16	80.45	TM-360-16X	88.85
11 - 32	.490	1.000	.300	.0020	.095	5	.5000	4.0	TM-490-16	92.95	TM-490-16X	103.25
11 - 32	.490	1.250	.300	.0020	.095	5	.5000	4.0	TM-490-20	92.95	TM-490-20X	103.25
10 - 32	.600	1.000	.420	.0020	.100	6	.6250	4.0	TM-600-16	115.55	TM-600-16X	127.95
10 - 32	.600	1.250	.420	.0020	.100	6	.6250	4.0	TM-600-20	115.55	TM-600-20X	127.95
TPI	$D_1^{+.0000}_{-.0050}$	$L_3^{+.0150}_{-.0000}$	$D_3$	$F^{+.0030}_{-.0000}$	$L_2$		$D_2$ (h6)	$L_1$	Tool #	Price	Tool #	Price
5 - 12	.720	1.250	.360	.0045	.200	6	.7500	4.0	TM-720-20	132.70	TM-720-20X	147.00
5 - 12	.720	2.000	.360	.0045	.200	6	.7500	4.0	TM-720-32	132.70	TM-720-32X	147.00
5 - 12	.720	2.500	.360	.0045	.200	6	.7500	4.0	TM-720-40	132.70	TM-720-40X	147.00



## TM

## Thread Milling Cutters

### Single Form – UN Threads – Reduced Shank

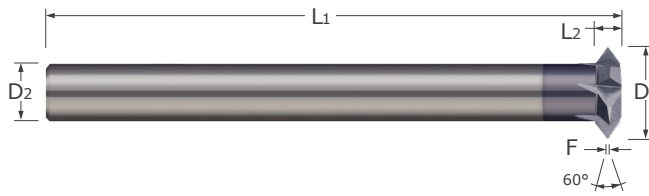

- Mills internal and external 60° threads
- Single thread form designed to mill common UN and metric pitch sizes
- Single form design reduces tool pressure for deep thread milling applications
- Reduced shank design can be chucked at any depth
- Mills right hand and left hand threads
- AlTiN coating option for added lubricity and increased wear resistance in difficult-to-machine materials
- Carbide head brazed to carbide shank
- CNC ground in the USA

Threads Per Inch	Cutter Diameter	Flat	Cutter Width	Flutes	Shank Diameter	Overall Length	Uncoated		AlTiN Coated	
							Tool #	Price	Tool #	Price
TPI	$D_1 \begin{smallmatrix} +.000'' \\ -.005'' \end{smallmatrix}$	$F \begin{smallmatrix} +.0030'' \\ -.0000'' \end{smallmatrix}$	$L_2 \begin{smallmatrix} +.005'' \\ -.005'' \end{smallmatrix}$		D2 (h6)	L1				
12-32	.375	.0020	.093	4	.2500	2.59	TM-375*	71.90	TM-375X*	76.80
11-32	.500	.0020	.125	5	.3125	2.63	TM-500*	87.55	TM-500X*	94.35
7-16	.750	.0040	.156	6	.3750	2.66	TM-750	108.60	TM-750X	115.40
5-12	1.000	.0045	.187	7	.5000	3.19	TM-001	141.80	TM-001X	150.00

\* Reduced Neck

# Thread Milling Cutters

## Multi-Form – UN Threads

TM

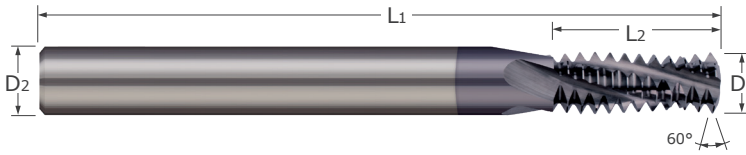

- Mills internal and external 60° UN threads
- Able to cut larger threads of the same pitch
- 100% thread form creates superior threads vs. tapping
- Mills right and left hand threads
- Helical flutes
- AlTiN coating option for added lubricity and increased wear resistance in difficult-to-machine materials
- Solid carbide
- CNC ground in the USA

Thread Size	Cutter Diameter D1 $\begin{matrix} +.0005" \\ -.0005" \end{matrix}$	Length of Cut* L2 $\begin{matrix} +.0500" \\ -.0000" \end{matrix}$	Flutes	Shank Diameter D2 (h6)	Overall Length L1	Uncoated		AlTiN Coated	
						Tool #	Price	Tool #	Price
4-40	.0800	.1875	2	.2500	2.0			TM-112-40X	126.90
6-32	.1000	.2500	2	.2500	2.0	TM-138-32	123.95	TM-138-32X	126.90
8-32	.1150	.2500	3	.2500	2.0			TM-164-32X	126.90
10-24	.1200	.3125	3	.2500	2.0	TM-190-24	129.35	TM-190-24X	132.30
10-28	.1200	.3125	3	.2500	2.0	TM-190-28	129.35	TM-190-28X	132.30
10-32	.1200	.3125	3	.2500	2.0	TM-190-32	129.35	TM-190-32X	132.30
1/4-20	.1800	.5000	3	.2500	2.5	TM-250-20	134.95	TM-250-20X	139.85
1/4-28	.1800	.5000	3	.2500	2.5	TM-250-28	134.95	TM-250-28X	139.85
5/16-18	.2350	.6250	3	.2500	2.5	TM-312-18	147.80	TM-312-18X	152.70
5/16-24	.2350	.6250	3	.2500	2.5			TM-312-24X	152.70
3/8-16	.2850	.7500	4	.3125	2.5	TM-375-16	178.25	TM-375-16X	185.05
3/8-24	.2850	.7500	4	.3125	2.5	TM-375-24	178.25	TM-375-24X	185.05
7/16-14	.3050	.7500	4	.3125	2.5	TM-437-14	178.25	TM-437-14X	185.05
7/16-20	.3350	.8750	4	.3750	3.0	TM-437-20	187.30	TM-437-20X	194.10
1/2-13	.3500	.8750	4	.3750	3.0	TM-500-13	187.30	TM-500-13X	194.10
9/16-12	.3700	.8750	4	.3750	3.0			TM-562-12X	194.10
9/16-18	.3700	.8750	4	.3750	3.0	TM-562-18	187.30	TM-562-18X	194.10
5/8-11	.4700	1.2500	4	.5000	4.0			TM-625-11X	224.75
3/4-10	.4950	1.2500	4	.5000	4.0	TM-750-10	214.45	TM-750-10X	224.75
3/4-12	.4950	1.2500	4	.5000	4.0	TM-750-12	214.45	TM-750-12X	224.75
3/4-16	.4950	1.2500	4	.5000	4.0	TM-750-16	214.45	TM-750-16X	224.75
7/8-14	.4900	1.2500	4	.5000	4.0	TM-875-14	215.30	TM-875-14X	225.60
7/8-9	.6200	1.3750	4	.6250	4.0			TM-875-09X	240.25
1-8	.6200	1.3750	4	.6250	4.0	TM-001-08	230.95	TM-001-08X	243.35

\* Length of cut measured to last full tooth.

TM

Thread Milling Cutters  
Multi-Form – NPT Threads

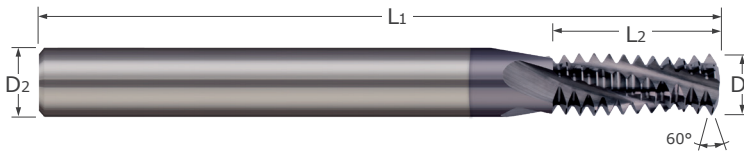

- Mills internal and external 60° NPT threads
- 100% thread form creates superior threads vs. tapping
- Mills right hand and left hand threads
- Helical flutes
- AlTiN coating option for added lubricity and increased wear resistance in difficult-to-machine materials
- Solid carbide ■ CNC ground in the USA

Thread Size	Major Cutter Diameter	Length of Cut*	Flutes	Shank Diameter	Overall Length	Uncoated		AlTiN Coated	
						Tool #	Price	Tool #	Price
	$D_1 \begin{smallmatrix} +.0005'' \\ -.0005'' \end{smallmatrix}$	$L_2 \begin{smallmatrix} +.050'' \\ -.000'' \end{smallmatrix}$		$D_2$ (h6)	$L_1$				
1/16 & 1/8-27 NPT	.2450	.437	3	.2500	2.5	TM-27NPT	148.30	TM-27NPTX	153.20
1/4 & 3/8-18 NPT	.3050	.625	4	.3125	3.0	TM-18NPT	178.80	TM-18NPTX	185.60
1/2 & 3/4-14 NPT	.4950	.875	4	.5000	4.0	TM-14NPT	180.10	TM-14NPTX	190.40
1 & 2-11.5 NPT	.6200	1.125	4	.6250	4.0	TM-11NPT	239.80	TM-11NPTX	252.20

\* Length of cut measured to last full tooth.

TM

Thread Milling Cutters  
Multi-Form – NPTF Threads

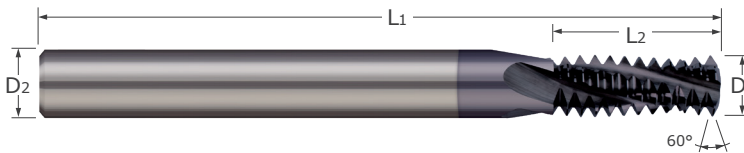

- Mills internal and external 60° NPTF threads
- 100% thread form creates superior threads vs. tapping
- Mills right hand and left hand threads
- Helical flutes
- AlTiN coating option for added lubricity and increased wear resistance in difficult-to-machine materials
- Solid carbide ■ CNC ground in the USA

Thread Size	Major Cutter Diameter	Length of Cut*	Flutes	Shank Diameter	Overall Length	Uncoated		AlTiN Coated	
						Tool #	Price	Tool #	Price
	$D_1 \begin{smallmatrix} +.0005'' \\ -.0005'' \end{smallmatrix}$	$L_2 \begin{smallmatrix} +.030'' \\ -.000'' \end{smallmatrix}$		$D_2$ (h6)	$L_1$				
1/16 & 1/8-27 NPT	.2450	.437	3	.2500	2.5	TM-27NPTF	168.60	TM-27NPTFX	173.50
1/4 & 3/8-18 NPT	.3050	.625	4	.3125	3.0			TM-18NPTFX	197.30
1/2 & 3/4-14 NPT	.4950	.875	4	.5000	4.0	TM-14NPTF	207.30	TM-14NPTFX	217.60
1 & 2-11.5 NPT	.6200	1.125	4	.6250	4.0			TM-11NPTFX	287.25

\* Length of cut measured to last full tooth.

# Thread Milling Cutters

## Multi-Form – Metric Threads

TMM

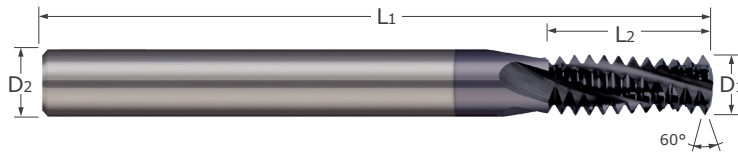

- Mills internal and external 60° metric thread
- Able to cut larger threads of the same pitch
- 100% thread form creates superior threads vs. tapping
- Mills right hand threads
- Helical flutes
- AlTiN coating option for added lubricity and increased wear resistance in difficult-to-machine materials
- Solid carbide ■ CNC ground in the USA

Thread Size	Cutter Diameter	Length of Cut*	Flutes	Shank Diameter	Overall Length	Uncoated		AlTiN Coated	
						Tool #	Price	Tool #	Price
	D <sub>1</sub> (h8)	L <sub>2</sub> <sup>+1.3 mm</sup> <sub>-0.0 mm</sub>		D <sub>2</sub> (h6)	L <sub>1</sub>				
M4.5-0.75	3.00 mm	6 mm	3	6 mm	57 mm	TMM-045075	122.55	TMM-045075X	127.45
M5.0-0.80	3.00 mm	8 mm	3	6 mm	57 mm			TMM-050080X	127.45
M6.0-1.00	4.30 mm	12 mm	3	6 mm	57 mm			TMM-060100X	140.60
M8.0-0.75	6.00 mm	16 mm	3	6 mm	57 mm	TMM-080075	171.35	TMM-080075X	176.25
M8.0-1.25	6.00 mm	16 mm	3	6 mm	57 mm			TMM-080125X	176.25
M10.0-1.50	7.62 mm	20 mm	4	8 mm	75 mm	TMM-100150	194.30	TMM-100150X	201.10
M12.0-1.00	9.15 mm	22 mm	4	10 mm	100 mm			TMM-120100X	203.20
M12.0-1.75	9.15 mm	22 mm	4	10 mm	100 mm			TMM-120175X	203.20
M18.0-1.50	11.94 mm	32 mm	4	12 mm	100 mm	TMM-180150	237.80	TMM-180150X	249.10
M20.0-2.50	11.94 mm	32 mm	4	12 mm	100 mm			TMM-200250X	249.10
M24.0-3.00	15.75 mm	35 mm	4	16 mm	100 mm	TMM-240300	277.40		

\* Length of cut measured to last full tooth.

## MTR

## Thread Milling Cutters

### Thread Relief Cutter

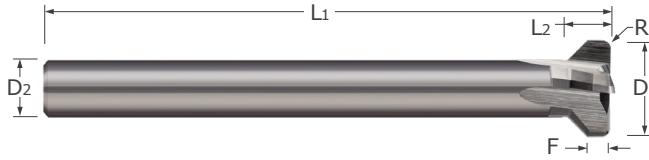

- Designed for milling thread relief at the bottom of a thread
- Relief operation typically done before threading to avoid thread form damage
- Chamfer eliminates burrs and partial threads at last thread
- Carbide head brazed to carbide shank
- CNC ground in the USA

Cutter Diameter	Cutter Width	Flat	Radius	Flutes	Shank Diameter	Overall Length	Uncoated	
							Tool #	Price
$D_1 \begin{smallmatrix} +.000'' \\ -.005'' \end{smallmatrix}$	$L_2 \begin{smallmatrix} +.015'' \\ -.015'' \end{smallmatrix}$	$F \begin{smallmatrix} +.000'' \\ -.005'' \end{smallmatrix}$	$R \begin{smallmatrix} +.002'' \\ -.002'' \end{smallmatrix}$		D2 (h6)	L1		
.375	.141	.075	.010	4	.2500	2.64	MTR-375	73.20
.500	.195	.100	.010	5	.3125	2.70	MTR-500	89.20
.750	.250	.125	.015	6	.3750	2.75	MTR-750	110.70
1.000	.250	.125	.015	7	.5000	3.25	MTR-001	144.45



**"THE ORIGINAL"**  
**SPEEDY SHARP**  
World's Fastest Sharpener®

Utilizing the same strong, durable carbide as Micro 100 cutting tools, the Speedy Sharp sharpens everything from pocket knives to lawn mower blades with ease.

**Quickly &  
Effectively  
Sharpens**

- Knives
- Scissors
- Axes
- Hunting Knives
- Gardening Tools
- Lawn Mower Blades
- Razor Blades
- Chisels
- Planer Blades
- Router Bits
- Fish Hooks

TOOL # KS-1

Add a Speedy Sharp (KS-1) to your tooling order today for only \$11.95!

Learn more at [speedysharp.com](http://speedysharp.com)

# Blanks, Sets & Accessories

Blanks .....	264
Half Round .....	264
Round .....	265
Split End .....	268
Sets .....	270
Standard Turning Sets .....	270
Brazed Sets .....	275
Indexable Sets .....	277
Combined Drill & Countersink Sets .....	282
Accessories .....	283
Indexable Inserts .....	283
Indexable Accessories .....	285



## Blanks

HR / HRM

## Half Round

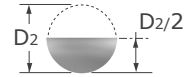
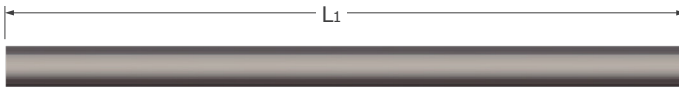

Blanks

- Half round style carbide blanks
- Polished split face
- Solid carbide
- CNC Ground in the USA

Split Height		Shank Diameter	Overall Length	Half Round Blank	
$D_2/2$	decimal equiv.			Tool #	Price
1 mm	.0394	2 mm	38 mm	HRM-020-38	14.80
1.5 mm	.0591	3 mm	38 mm	HRM-030-38	15.60
.0625	.0625	.1250	1.5	HR-125	21.80
.0938	.0938	.1870	2.0	HR-187	28.60
2.5 mm	.0984	5 mm	50 mm	HRM-050-50	26.00
3 mm	.1181	6 mm	57 mm	HRM-060-57	31.10
.1250	.1250	.2500	2.5	HR-250	37.90
4 mm	.1575	8 mm	63 mm	HRM-080-63	51.20
5 mm	.1969	10 mm	72 mm	HRM-100-72	72.10



SR / SRM

Blanks  
Round Blanks

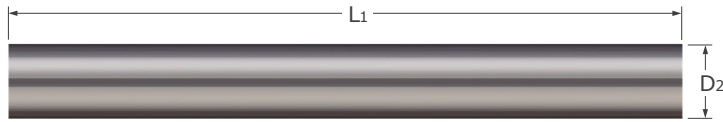

- Round style
- Finish ground blanks
- Solid carbide
- CNC ground in the USA

Shank Diameter		Overall Length	Round Blank	
D2(h6)		L1	Tool #	Price
1 mm	.0394	30 mm	SRM-010-030	4.30
1 mm	.0394	310 mm	SRM-010-310	13.10
1.5 mm	.0591	100 mm	SRM-015-100	6.20
.0625	.0625	1.0	SR-062-1	6.90
.0625	.0625	2.0	SR-062-2	6.80
.0625	.0625	3.0	SR-062-3	6.60
.0625	.0625	4.0	SR-062-4	6.30
.0625	.0625	6.0	SR-062-6	9.80
.0625	.0625	12.0	SR-062-12	17.80
2 mm	.0787	38 mm	SRM-020-038	4.90
2 mm	.0787	100 mm	SRM-020-100	8.10
2 mm	.0787	310 mm	SRM-020-310	17.70
.0938	.0938	1.0	SR-093-1	7.60
.0938	.0938	3.0	SR-093-3	8.90
.0938	.0938	4.0	SR-093-4	11.00
.0938	.0938	6.0	SR-093-6	11.30
.0938	.0938	12.0	SR-093-12	16.50
2.5 mm	.0984	100 mm	SRM-025-100	8.10
3 mm	.1181	38 mm	SRM-030-038	5.50
3 mm	.1181	100 mm	SRM-030-100	9.70
3 mm	.1181	310 mm	SRM-030-310	23.70
.1250	.1250	1.5	SR-125-1.5	6.00
.1250	.1250	2.0	SR-125-2	6.80
.1250	.1250	3.0	SR-125-3	8.20
.1250	.1250	4.0	SR-125-4	10.40
.1250	.1250	6.0	SR-125-6	15.80
.1250	.1250	12.0	SR-125-12	26.90
3.5 mm	.1378	100 mm	SRM-035-100	13.60
.1562	.1562	1.5	SR-156-1.5	7.40
.1562	.1562	2.0	SR-156-2	9.40
.1562	.1562	3.0	SR-156-3	12.20
.1562	.1562	4.0	SR-156-4	14.10
.1562	.1562	6.0	SR-156-6	24.50
.1562	.1562	12.0	SR-156-12	34.50

\*Denotes chamfered end.

Continued on next page

## Blanks

SR / SRM

## Round Blanks (cont.)

Continued from previous page

Shank Diameter		Overall Length	Round Blank	
D2(h6)		L1	Tool #	Price
4 mm	.1575	50 mm	SRM-040-050	6.60
4 mm	.1575	100 mm	SRM-040-100	13.80
4 mm	.1575	310 mm	SRM-040-310	33.90
4.5 mm	.1772	100 mm	SRM-045-100	16.30
.1875	.1875	1.5	SR-187-1.5*	7.70
.1875	.1875	2.0	SR-187-2*	8.90
.1875	.1875	4.0	SR-187-4	17.10
.1875	.1875	6.0	SR-187-6	24.70
.1875	.1875	12.0	SR-187-12	44.40
5 mm	.1969	50 mm	SRM-050-050	8.40
5 mm	.1969	100 mm	SRM-050-100	18.80
5 mm	.1969	310 mm	SRM-050-310	54.30
5.5 mm	.2165	100 mm	SRM-055-100	20.60
6 mm	.2362	57 mm	SRM-060-057	12.70
6 mm	.2362	100 mm	SRM-060-100	25.00
6 mm	.2362	310 mm	SRM-060-310	64.30
.2500	.2500	2.0	SR-250-2*	13.10
.2500	.2500	2.5	SR-250-2.5*	15.60
.2500	.2500	3.0	SR-250-3*	16.30
.2500	.2500	4.0	SR-250-4	24.90
.2500	.2500	6.0	SR-250-6	35.70
.2500	.2500	12.0	SR-250-12	66.50
6.5 mm	.2559	100 mm	SRM-065-100	25.90
7 mm	.2756	100 mm	SRM-070-100	33.00
7 mm	.2756	310 mm	SRM-070-310	94.20
.3125	.3125	2.0	SR-312-2*	16.70
.3125	.3125	2.5	SR-312-2.5*	20.20
.3125	.3125	4.0	SR-312-4*	36.60
.3125	.3125	6.0	SR-312-6	50.90
.3125	.3125	12.0	SR-312-12	91.90
8 mm	.3150	100 mm	SRM-080-100	33.40
8 mm	.3150	310 mm	SRM-080-310	87.00
9 mm	.3543	100 mm	SRM-090-100	34.20
9 mm	.3543	310 mm	SRM-090-310	104.50
.3750	.3750	2.0	SR-375-2*	20.40
.3750	.3750	2.5	SR-375-2.5*	25.10
.3750	.3750	4.0	SR-375-4*	41.00
.3750	.3750	6.0	SR-375-6	62.40
.3750	.3750	12.0	SR-375-12	119.30
10 mm	.3937	72 mm	SRM-100-072	30.30
10 mm	.3937	100 mm	SRM-100-100	50.00
10 mm	.3937	310 mm	SRM-100-310	141.20
.4375	.4375	2.5	SR-437-2.5*	50.50
.4375	.4375	4.0	SR-437-4	74.70
.4375	.4375	6.0	SR-437-6	114.40
.4375	.4375	12.0	SR-437-12	176.30

\*Denotes chamfered end.

Continued on next page

SR / SRM

Blanks  
Round Blanks (cont.)

Continued from previous page

Shank Diameter		Overall Length	Round Blank	
D <sub>2</sub> (h6)		L <sub>1</sub>	Tool #	Price
12 mm	.4724	83 mm	SRM-120-083	47.10
12 mm	.4724	100 mm	SRM-120-100	65.70
12 mm	.4724	310 mm	SRM-120-310	187.70
.5000	.5000	2.5	SR-500-2.5*	39.40
.5000	.5000	3.0	SR-500-3*	41.40
.5000	.5000	4.0	SR-500-4	63.30
.5000	.5000	6.0	SR-500-6	96.60
.5000	.5000	12.0	SR-500-12	217.60
13 mm	.5118	310 mm	SRM-130-310	191.20
14 mm	.5512	100 mm	SRM-140-100	94.10
.5625	.5625	3.5	SR-562-3.5*	79.50
.6250	.6250	3.5	SR-625-3.5*	98.30
.6250	.6250	4.0	SR-625-4	98.60
.6250	.6250	6.0	SR-625-6	143.60
.6250	.6250	12.0	SR-625-12	273.80
16 mm	.6299	100 mm	SRM-160-100	96.90
16 mm	.6299	310 mm	SRM-160-310	277.50
.6875	.6875	6.0	SR-687-6	285.50
18 mm	.7087	100 mm	SRM-180-100	132.50
.7500	.7500	4.0	SR-750-4*	117.60
.7500	.7500	6.0	SR-750-6	225.10
.7500	.7500	12.0	SR-750-12	368.30
20 mm	.7874	100 mm	SRM-200-100	143.20
25 mm	.9843	310 mm	SRM-250-310	618.90
1.0000	1.0000	4.0	SR-001-4*	260.60
1.0000	1.0000	5.0	SR-001-5*	382.60
1.0000	1.0000	6.0	SR-001-6	409.60
1.0000	1.0000	12.0	SR-001-12	640.20

\*Denotes chamfered end.

Blanks

## Blanks

RS /RSM

## Split End – Single Ended

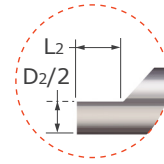
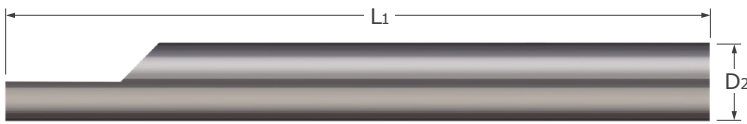

- Precision ground blank designed for custom profiles requiring a split face
- Precision manufactured in the USA

Split Length*			Shank Diameter	Overall Length	Single-Ended Blank	
L2 +.015" -.000"	+1.0 mm -0.0 mm	decimal equiv.	D2 (h6)	L1	Tool #	Price
					4 mm	.1575
6 mm	.2362	4 mm	50 mm	RSM-040-1	12.10	
8 mm	.3150	6 mm	57 mm	RSM-060-1	17.70	
.375	.3750	.1250	1.5	RS-125-1	15.20	
.375	.3750	.1250	3.0	RS-125-13	17.10	
.375	.3750	.1875	2.0	RS-187-1	18.50	
.375	.3750	.1875	3.0	RS-187-13	25.40	
.375	.3750	.2500	2.5	RS-250-1	23.90	
.375	.3750	.2500	4.0	RS-250-14	37.80	
10 mm	.3937	8 mm	63 mm	RSM-080-1	33.20	
12 mm	.4724	10 mm	72 mm	RSM-100-1	43.90	
.500	.5000	.3125	2.5	RS-312-1	35.70	
.500	.5000	.3125	4.0	RS-312-14	54.40	
.500	.5000	.3750	2.5	RS-375-1	46.70	
.500	.5000	.3750	4.0	RS-375-14	73.80	
.625	.6250	.5000	3.0	RS-500-1	79.50	
.625	.6250	.5000	4.0	RS-500-14	109.20	

\* Centerline +.0010" / -.0000" and +.024 mm / -.000 mm

RS /RSM

Blanks

Split End – Double Ended

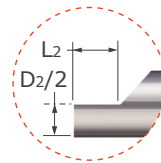
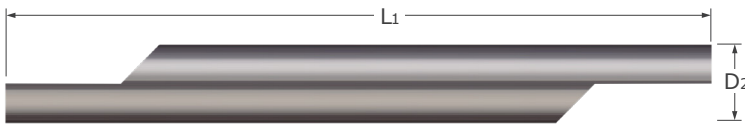

- Precision ground blank designed for custom profiles requiring a split face
- Double-ended allows for maximum utilization of the blank
- Precision manufactured in the USA

Split Length*			Shank Diameter	Overall Length	Double-Ended Blank	
+.015" -.015"	L2 +1.0 mm -0.0 mm	decimal equiv.	D2 (h6)	L1	Tool #	Price
					4 mm	.1575
	5 mm	.1969	3 mm	38 mm	RSM-030-2	12.90
	6 mm	.2362	4 mm	50 mm	RSM-040-2	16.00
	8 mm	.3150	6 mm	57 mm	RSM-060-2	23.60
.375		.3750	.1250	1.5000	RS-125-2	21.00
.375		.3750	.1250	3.0000	RS-125-23	22.60
.375		.3750	.1875	2.0000	RS-187-2	25.60
.375		.3750	.1875	3.0000	RS-187-23	31.60
.375		.3750	.2500	2.5000	RS-250-2	32.40
.375		.3750	.2500	4.0000	RS-250-24	44.50
	10 mm	.3937	8 mm	63 mm	RSM-080-2	42.40
	12 mm	.4724	10 mm	72 mm	RSM-100-2	59.10
.500		.5000	.3125	2.5000	RS-312-2	47.50
.500		.5000	.3125	4.0000	RS-312-24	66.70
.500		.5000	.3750	2.5000	RS-375-2	58.60
.500		.5000	.3750	4.0000	RS-375-24	87.50
.625		.6250	.5000	3.0000	RS-500-2	94.20
.625		.6250	.5000	4.0000	RS-500-24	134.90

\* Centerline +.0010" / -.0000" and +.024 mm / -.000 mm

## Sets

### Standard – Boring Tools – Right Hand – Sharp – Miniature

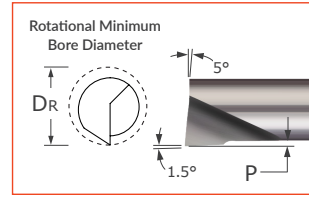
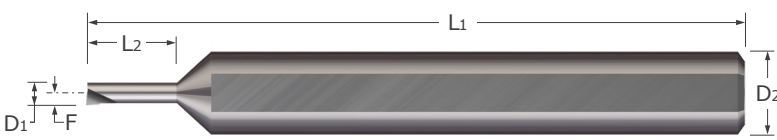

Sets

- Designed for facing and boring applications in bores .015" and larger
- Polished face for improved edge retention and chip evacuation while reducing galling
- Split geometry makes the tool as rigid as possible
- On center neck design allows for static (D<sub>1</sub>) and live/rotating (D<sub>R</sub>) applications
- Sharp corner profile
- Lockdown flat automatically locates tool on center
- AlTiN coated option provides added lubricity and increased wear resistance in difficult to machine materials
- Solid carbide
- CNC ground in the USA



Minimum Bore Diameter	Rotational Minimum Bore Diameter	Maximum Bore Depth	Projection	Centerline Offset	Shank Dia.	OAL	Uncoated	Set
D <sub>1</sub>	D <sub>R</sub>	L <sub>2</sub> <sup>+ .010"</sup> <sub>- .000"</sub>	P	F	D <sub>2</sub> (h6)	L <sub>1</sub>	Tool #	Set #      Price
.0180	.020	.075	.002	.0100	.1250	1.5	MBB-020075	MBB-0      206.60
.0225	.025	.100	.003	.0130	.1250	1.5	MBB-025100	
.0270	.030	.100	.003	.0150	.1250	1.5	MBB-030100	
.0315	.035	.100	.004	.0175	.1250	1.5	MBB-035100	
.0360	.040	.150	.004	.0200	.1250	1.5	MBB-040150	
.0405	.045	.150	.005	.0225	.1250	1.5	MBB-045150	

Sets

Standard – Boring Tools – Right Hand

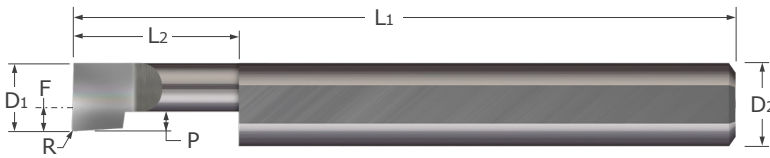

- Designed for facing and boring applications in bores .050" and larger
- Polished split face for improved edge retention and chip evacuation while reducing galling
- Split geometry makes the tool as rigid as possible
- Corner radius profile
- Lockdown flat automatically locates tool on center
- Coating options provide added lubricity and increased wear resistance in difficult to machine materials
- Solid carbide ■ CNC ground in the USA

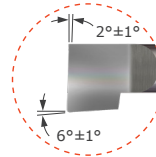

Shank Dia.	Minimum Bore Dia.	Maximum Bore Depth	Radius	Projection	Centerline Offset	Overall Length	Uncoated	Set	
D <sub>2</sub> (h6)	D <sub>1</sub>	L <sub>2</sub> $\begin{smallmatrix} +.050'' \\ -.000'' \end{smallmatrix}$	R $\begin{smallmatrix} +.003'' \\ -.000'' \end{smallmatrix}$	P	F	L <sub>1</sub>	Tool #	Set #	Price
1/8	.050	.300	.003	.012	-.013	1.5	BB-050300	BB-1	156.80
	.060	.300	.003	.015	-.003	1.5	BB-060300		
	.080	.300	.003	.020	.018	1.5	BB-080300		
	.100	.400	.003	.025	.038	1.5	BB-100400		
	.100	.500	.003	.025	.038	1.5	BB-100500		
	.100	.600	.003	.025	.038	1.5	BB-100600		
3/16	.120	.500	.006	.030	.026	2.0	BB-120500	BB-2	166.80
	.120	.700	.006	.030	.026	2.0	BB-120700		
	.140	.400	.006	.035	.046	2.0	BB-140400		
	.140	.700	.006	.035	.046	2.0	BB-140700		
	.160	.400	.006	.040	.066	2.0	BB-160400		
	.160	.750	.006	.040	.066	2.0	BB-160750		
1/4	.180	.500	.006	.045	.055	2.5	BB-180500	BB-3	180.00
	.180	.750	.006	.045	.055	2.5	BB-180750		
	.180	1.000	.006	.045	.055	2.5	BB-1801000		
	.200	.400	.006	.050	.075	2.5	BB-200400		
	.200	.600	.006	.050	.075	2.5	BB-200600		
	.200	1.000	.006	.050	.075	2.5	BB-2001000		
5/16	.230	.400	.006	.057	.074	2.5	BB-230400	BB-4	242.90
	.230	.600	.006	.057	.074	2.5	BB-230600		
	.230	.800	.006	.057	.074	2.5	BB-230800		
	.230	1.000	.006	.057	.074	2.5	BB-2301000		
	.290	.500	.006	.072	.134	2.5	BB-290500		
	.290	1.000	.006	.072	.134	2.5	BB-2901000		
3/8	.320	.500	.006	.080	.133	2.5	BB-320500	BB-5	331.20
	.320	1.000	.006	.080	.133	2.5	BB-3201000		
	.320	1.250	.006	.080	.133	2.5	BB-3201500		
	.360	.750	.006	.090	.173	2.5	BB-360750		
	.360	1.250	.006	.090	.173	2.5	BB-3601250		
	.360	1.800	.006	.090	.173	2.5	BB-3601800		

## Sets

### Standard – Grooving Tools – Retaining Ring – Right Hand

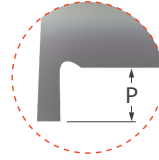
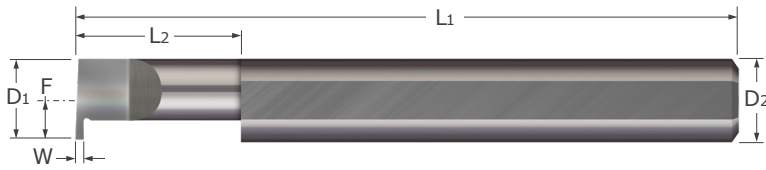

- Designed for generating retaining ring grooves
- Polished split face for improved edge retention and chip evacuation while reducing galling
- Sharp corner profile
- Lockdown flat automatically locates tool on center
- Coating options provide added lubricity and increased wear resistance in difficult to machine materials
- Solid carbide ■ CNC ground in the USA

Width	Min. Bore Diameter	Max. Bore Depth	Projection	Centerline Offset	Shank Diameter	Overall Length	Uncoated	Set	
W $^{+.001"}$ $_{-.000"}$	D1	L2 $^{+.050"}$ $_{-.000"}$	P	F	D2 (h6)	L1	Tool #	Set #	Price
.017	.250	.250	.050	.125	.2500	2.5	RR-017-4	RR-1	227.80
.025	.250	.625	.050	.125	.2500	2.5	RR-025-10		
.030	.250	.500	.050	.125	.2500	2.5	RR-030-8		
.030	.250	.625	.050	.125	.2500	2.5	RR-030-10		
.033	.312	.500	.100	.156	.3125	2.5	RR-033-8		
.033	.312	.750	.100	.156	.3125	2.5	RR-033-12		
W $^{+.002"}$ $_{-.000"}$	D1	L2 $^{+.050"}$ $_{-.000"}$	P	F	D2 (h6)	L1	Tool #	Set #	Price
.039	.375	.750	.100	.188	.3750	2.5	RR-039-12	RR-2	342.60
.046	.375	1.000	.100	.188	.3750	2.5	RR-046-16		
.055	.375	1.250	.100	.188	.3750	2.5	RR-055-20		
.062	.375	.750	.100	.188	.3750	2.5	RR-062-12		
.087	.375	.750	.100	.188	.3750	2.5	RR-087-12		
.087	.375	1.250	.100	.188	.3750	2.5	RR-087-20		

Sets



Sets

Standard – Threading Tools – UN Threads – Single Point – Right Hand

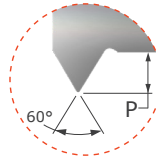
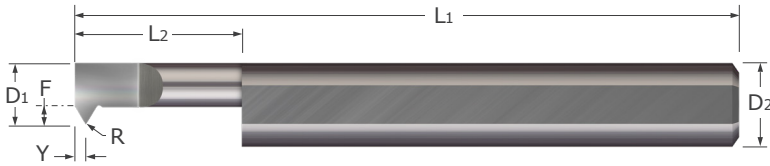

- Designed for threading multiple thread pitches (ANSI, UN, and Metric 60°)
- Polished split face for improved edge retention and chip evacuation while reducing galling
- Split geometry makes the tool as rigid as possible
- Corner radius profile
- Lockdown flat automatically locates tool on center
- AlTiN coated option provides added lubricity and increased wear resistance in difficult to machine materials
- Solid carbide ■ CNC ground in the USA

Threads Per Inch	Minimum Bore Diameter	Maximum Bore Depth	Point Offset	Projection	Radius	Centerline Offset	Shank Diameter	Overall Length	Uncoated	Set	
									Tool #	Set #	Price
TPI	D <sub>1</sub>	L <sub>2</sub>	Y	P	R	F	D <sub>2</sub> (h6)	L <sub>1</sub>			
		$^{+.050''}_{-.000''}$	$^{+.010''}_{-.000''}$		$^{+.001''}_{-.000''}$						
24-56	.180	.500	.023	.040	.002	.055	.2500	2.5	IT-180500	IT-1	287.70
24-40	.200	.600	.026	.045	.002	.075	.2500	2.5	IT-200600		
20-40	.230	.600	.032	.055	.002	.074	.3125	2.5	IT-230600		
14-40	.290	.750	.040	.070	.002	.134	.3125	2.5	IT-290750		
10-32	.320	.750	.043	.075	.002	.133	.3750	2.5	IT-320750		
10-32	.360	.750	.049	.085	.002	.173	.3750	2.5	IT-360750		

Sets

## Sets

### Standard – Boring Tools – Right Hand – Brazed

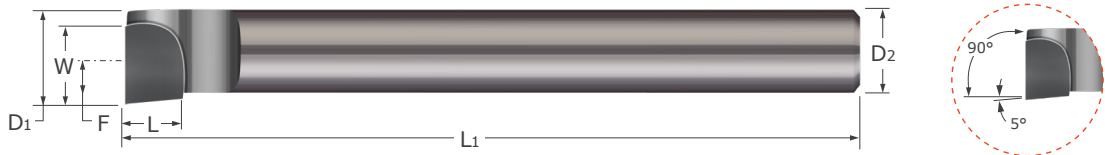

- Designed for right hand facing and boring applications in bores .320" and larger
- Long shank enables flexible reach options (preset at any length)
- Sharp corner profile
- Steel shank with brazed tip ■ CNC ground in the USA

Minimum Groove Diameter	Width	Length	Centerline Offset	Shank Diameter	Overall Length	Brazed Style	Set	
D1	W	L	F	D2 $\begin{smallmatrix} +.000" \\ -.003" \end{smallmatrix}$	L1	Tool #	Set #	Price
.320	.250	.188	.195	.250	4.0	TBB-250	TBB-5	140.10
.463	.313	.250	.276	.375	6.0	TBB-375		
.625	.500	.250	.375	.500	7.0	TBB-500		
.795	.500	.250	.483	.625	8.0	TBB-625		
.935	.625	.250	.560	.750	9.0	TBB-750		

## Sets

### Standard – Boring Tools – Left Hand – Brazed

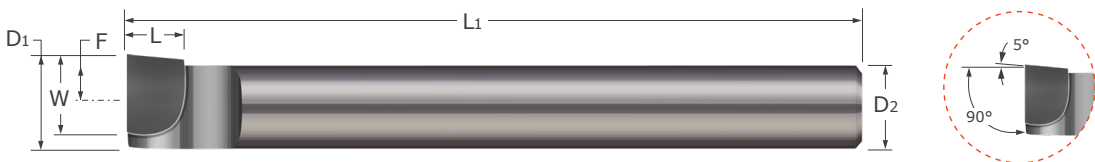

- Designed for left hand facing and boring applications in bores .320" and larger
- Long shank enables flexible reach options (preset at any length)
- Sharp corner profile
- Steel shank with brazed tip ■ CNC ground in the USA

Minimum Bore Diameter	Width	Length	Centerline Offset	Shank Diameter	Overall Length	Brazed Style	Set	
D1	W	L	F	D2 $\begin{smallmatrix} +.000" \\ -.003" \end{smallmatrix}$	L1	Tool #	Set #	Price
.320	.250	.188	.195	.250	4.0	TBBL-250	TBBL-5	137.10
.463	.313	.250	.276	.375	6.0	TBBL-375		
.625	.500	.250	.375	.500	7.0	TBBL-500		
.795	.500	.250	.483	.625	8.0	TBBL-625		
.935	.625	.250	.560	.750	9.0	TBBL-750		

Sets

Brazed – Forming Tools – 90° Radius Concave – Right Hand



- Right hand tool designed for forming a convex radius
- Tangential 5° blend angles aid in providing a burr-free transition
- Zinc coated shanks provide durability and corrosion resistance
- Available in industry standard fractional shank sizes
- Ground in the USA

Radius	Square Shank	Overall Length	Brazed	Set	
$R \begin{smallmatrix} +.0005" \\ -.0005" \end{smallmatrix}$	$A \begin{smallmatrix} +.0000" \\ -.0050" \end{smallmatrix}$	C	Tool #	Set #	Price
.0625	.3750	2.5	RAD-2	RAD-21	170.00
.1250	.3750	2.5	RAD-4		
.2500	.3750	2.5	RAD-8		
.3750	.5000	3.5	RAD-12		
.0312	.3750	2.5	RAD-1	RAD-22	332.00
.0625	.3750	2.5	RAD-2		
.0938	.3750	2.5	RAD-3		
.1250	.3750	2.5	RAD-4		
.1562	.3750	2.5	RAD-5		
.1875	.3750	2.5	RAD-6		
.2188	.3750	2.5	RAD-7		
.2500	.3750	2.5	RAD-8		
.0625	.3750	2.5	RAD-2	RAD-23	358.00
.1250	.3750	2.5	RAD-4		
.1875	.3750	2.5	RAD-6		
.2500	.3750	2.5	RAD-8		
.3125	.5000	3.5	RAD-10		
.3750	.5000	3.5	RAD-12		
.4375	.7500	4.5	RAD-14		
.5000	.7500	4.5	RAD-16		
.0312	.3750	2.5	RAD-1	RAD-24	716.00
.0625	.3750	2.5	RAD-2		
.0938	.3750	2.5	RAD-3		
.1250	.3750	2.5	RAD-4		
.1562	.3750	2.5	RAD-5		
.1875	.3750	2.5	RAD-6		
.2188	.3750	2.5	RAD-7		
.2500	.3750	2.5	RAD-8		
.2812	.5000	3.5	RAD-9		
.3125	.5000	3.5	RAD-10		
.3438	.5000	3.5	RAD-11		
.3750	.5000	3.5	RAD-12		
.4062	.7500	4.5	RAD-13		
.4375	.7500	4.5	RAD-14		
.4688	.7500	4.5	RAD-15		
.5000	.7500	4.5	RAD-16		

Sets

## Sets

### Brazed – Forming Tools – 90° Radius Concave – Left Hand



Sets

- Left hand tool designed for forming a convex radius
- Tangential 5° blend angles
- Zinc coated shanks provide durability and corrosion resistance
- Available in industry standard fractional shank sizes
- Ground in the USA

Radius	Square Shank	Overall Length	Brazed	Set	
$R \begin{matrix} +.0005'' \\ -.0005'' \end{matrix}$	$A \begin{matrix} +.0000'' \\ -.0050'' \end{matrix}$	C	Tool #	Set #	Price
.0625	.3750	2.5	RAL-2	RAL-21	170.00
.1250	.3750	2.5	RAL-4		
.2500	.3750	2.5	RAL-8		
.3750	.5000	3.5	RAL-12		

Sets

Indexable Boring Bars – Boring – Coolant Through – Right Hand

Set Contents	Holder Nomenclature	Part Number	Set	
			Tool #	Set # Price
4 SCLCR Tool Holders 1/4", 5/16", 3/8", and 1/2" Shank Diameters	A04F SCLCR 2	20-0821	40-0100	286.90
	A05H SCLCR 2	20-0823		
	A06J SCLCR 2	20-0825		
	A08K SCLCR 2	20-0827		
4 Inserts	-	50-1100		
4 M2.5 x T-8 Torx Screws	-	16-1020		
1 Torx Key M2.5 x TK-8	-	16-1060		
3 Tool Holders 1/2", 5/8", 3/4" Shank Diameters	A08K SCLCR 3	20-0850	40-2500	341.80
	A10M SCLCR 3	20-0852		
	A12Q SCLCR 3	20-0854		
3 Inserts	-	50-1100		
3 M2.5 x T-8 Torx Screws	-	16-1020		
1 Torx Key M3.5 x TK-15	-	16-1070		



Sets

Sets

Indexable Boring Bars – Facing – Coolant Through – Right Hand

Set Contents	Holder Nomenclature	Part Number	Set	
			Tool #	Set # Price
3 STFCR Tool Holders 3/8", 1/2", and 5/8" Shank Diameters	A06J STFCR 2	20-1031	40-2100	241.30
	A08K STFCR 2	20-1033		
	A10M STFCR 2	20-1035		
3 Inserts	-	50-1300		
3 M2.5 x T-8 Torx Screws	-	16-1020		
1 Torx Key M2.5 x TK-8	-	16-1060		



## Sets

### Indexable Boring Bars – Profiling – Coolant Through – Right Hand

Sets



Set Contents	Holder Nomenclature	Part Number	Set	
			Tool #	Set #
3 SDUCR Tool Holders 3/8", 1/2", and 5/8" Shank Diameters	A06J SDUCR 2	20-0931	40-2400	241.30
	A08K SDUCR 2	20-0933		
	A10M SDUCR 2	20-0935		
3 Inserts	-	50-1200		
3 M2.5 x T-8 Torx Screws	-	16-1020		
1 Torx Key M2.5 x TK-8	-	16-1060		

Sets

Indexable Boring Bars – Multi-Purpose Set 1



Set Contents	Holder Nomenclature	Part Number	Set	
			Tool #	Set #
7 Assorted Tool Holders 1/4" Shank Diameters	SCLCR 0404 D2	10-3231	40-7101	259.50
	SCLCR 0505 D2	10-3232		
	SCBCR 0404 D2	10-3151		
	SCKCR 0404 D2	10-3211		
	SCMCN 0404 D2	10-3311		
	SCSCR 0404 D2	10-3351		
	A04F SCLCR 2	20-0821		
7 Inserts	-	50-1100		
7 M2.5 x T-8 Torx Screws	-	16-1020		
1 Torx Key M2.5 x TK-8	-	16-1060		
7 Assorted Tool Holders 5/16" Shank Diameters	SCLCR 0505 D2	10-3233	40-7102	267.30
	SCLCL 0505 D2	10-3234		
	SCBCR 0505 D2	10-3153		
	SCKCR 0505 D2	10-3212		
	SCMCN 0505 D2	10-3312		
	SCSCR 0505 D2	10-3353		
	A05H SCLCR 2	20-0823		
7 Inserts	-	50-1100		
7 M2.5 x T-8 Torx Screws	-	16-1020		
1 Torx Key M2.5 x TK-8	-	16-1060		
7 Assorted Tool Holders 3/8" Shank Diameters	SCLCR 0606 E2	10-3235	40-7103	280.30
	SCLCL 0606 E2	10-3236		
	SCBCR 0606 E2	10-3155		
	SCKCR 0606 E2	10-3213		
	SCMCN 0606 E2	10-3313		
	SCSCR 0606 E2	10-3355		
	A06J SCLCR 2	20-0825		
7 Inserts	-	50-1100		
7 M2.5 x T-8 Torx Screws	-	16-1020		
1 Torx Key M2.5 x TK-8	-	16-1060		
7 Assorted Tool Holders 1/2" Shank Diameters	SCLCR 0808 F2	10-3237	40-7104	300.00
	SCLCL 0808 F2	10-3238		
	SCBCR 0808 F2	10-3157		
	SCKCR 0808 F2	10-3215		
	SCMCN 0808 F2	10-3314		
	SCSCR 0808 F2	10-3357		
	A08K SCLCR 2	20-0827		
7 Inserts	-	50-1100		
7 M2.5 x T-8 Torx Screws	-	16-1020		
1 Torx Key M2.5 x TK-8	-	16-1060		

Continued on next page

Sets

## Sets

### Indexable Boring Bars – Multi-Purpose Set 1 (cont.)

Continued from previous page



Set Contents	Holder Nomenclature	Part Number	Set	
			Tool #	Set #
7 Assorted Tool Holders 5/8" Shank Diameters	SCLCR 1010 H2	10-3241	40-7105	404.30
	SCLCL 1010 H2	10-3242		
	SCBCR 1010 H2	10-3159		
	SCKCR 1010 H2	10-3217		
	SCMCN 1010 H2	10-3315		
	SCSCR 1010 H2	10-3359		
	A10M SCLCR 2	20-0829		
7 Inserts	-	50-1100		
7 M2.5 x T-8 Torx Screws	-	16-1020		
1 Torx Key M2.5 x TK-8	-	16-1060		

Sets

## Sets

### Indexable Boring Bars – Multi-Purpose Set 2



Set Contents	Holder Nomenclature	Part Number	Set	
			Tool #	Set #
4 Tool Holders 3/4" Shank Diameters	SCLCR 1212 J3	10-3251	40-7150	435.05
	SCLCL 1212 J3	10-3252		
	SCSCR 1212 J3	10-3365		
	A12Q SCLCR 3	20-0854		
4 Inserts	-	50-1105		
4 M2.5 x T-8 Torx Screws	-	16-1020		
1 Torx Key M3.5 x TK-15	-	16-1070		



Sets

Indexable Boring Bars – Multi-Purpose Set 3

Set Contents	Holder Nomenclature	Part Number	Set	
			Tool #	Set # Price
4 Assorted Tool Holders 5/16" Shank Diameters	SDJCR 0505 H2	10-3641	40-7200	212.00
	SDJCL 0505 H2	10-3642		
	SDNCN 0505 H2	10-3761		
	A05H SDQCR 2	20-0901		
	-	50-1200		
4 Inserts	-	50-1200		
4 M2.5 x T-8 Torx Screws	-	16-1020		
1 Torx Key M2.5 x TK-8	-	16-1060		
4 Assorted Tool Holders 3/8" Shank Diameters	SDJCR 0606 H2	10-3651	40-7201	234.70
	SDJCL 0606 H2	10-3652		
	SDNCN 0606 H2	10-3762		
	A06J SDUCR 2	20-0931		
	-	50-1200		
4 Inserts	-	50-1200		
4 M2.5 x T-8 Torx Screws	-	16-1020		
1 Torx Key M2.5 x TK-8	-	16-1060		
4 Assorted Tool Holders 1/2" Shank Diameters	SDJCR 0808H2	10-3653	40-7202	259.50
	SDJCL 0808H2	10-3654		
	SDNCN 0808 H2	10-3763		
	A08K SDUCR 2	20-0933		
	-	50-1200		
4 Inserts	-	50-1200		
4 M2.5 x T-8 Torx Screws	-	16-1020		
1 Torx Key M2.5 x TK-8	-	16-1060		
4 Assorted Tool Holders 5/8" Shank Diameters	SDJCR 1010 H2	10-3615	40-7203	319.50
	SDJCL 1010 H2	10-3616		
	SDNCN 1010 H2	10-3764		
	A10M SDUCR 2	20-0935		
	-	50-1200		
4 Inserts	-	50-1200		
4 M2.5 x T-8 Torx Screws	-	16-1020		
1 Torx Key M2.5 x TK-8	-	16-1060		



Sets

## Sets

### Indexable – Milling – Tool Holders – Coolant Through

Sets

Set Contents	Holder Nomenclature	Part Number		Set	
		Tool #	Set #	Price	
3 Tool Holders 1/2" Shank Diameters	AAAP 1216 2	30-1216	60-3003	319.50	
	AAAP 1616 2	30-1616			
	AAAP 1816 2	30-1816			
4 Inserts	-	50-2100			
4 M2.5 x T-8 Torx Screws	-	16-1020			
1 Torx Key M3.5 x TK-15	-	16-1070			



## Sets

### Combined Drill & Countersinks

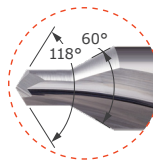
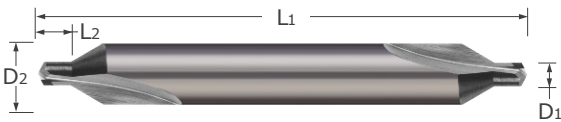



- Designed for predrilling 60° live center holes
- Can be utilized for countersinking and spot drilling
- Double-ended for quicker tool changes
- Solid carbide ■ CNC ground in the USA

Drill Diameter	Drill Length	Shank Diameter	Overall Length	Uncoated	Set	
				Tool #	Set #	Price
D1 $^{+.0030''}$ $_{-.0000''}$	L2	D2 (h6)	L1			
.0469	.047	.1250	1.500	DC-1	DC-0	348.00
.0781	.078	.1875	1.875	DC-2		
.1094	.109	.2500	2.000	DC-3		
.1250	.125	.3125	2.125	DC-4		
.1875	.188	.4375	2.750	DC-5		
.2188	.219	.5000	3.000	DC-6		

# Indexable Inserts

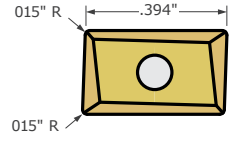
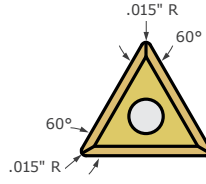
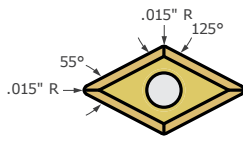
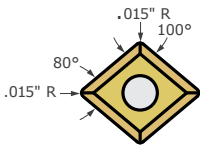
## Indexable Cutters – Inserts



Insert Type	Insert*	
	Tool #	Price
	50-1100	10.15
	50-1105	12.45
	50-1200	10.75
	50-1300	9.05
	50-2100	11.25

\*Must be ordered in quantities of 10.

## Indexable Inserts

CPG / SPG

### Indexable Cutters – Generic Inserts – Diamond Style

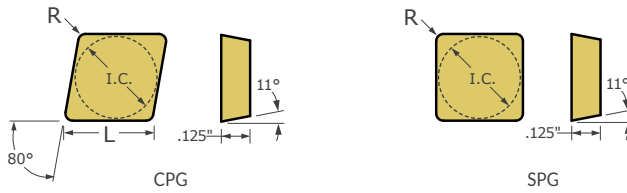

- 80° diamond insert with radius on corner
- For use in clamp locking style holder

Inscribed Circle	Length	Radius	Style	Diamond Style Insert	
				Tool #	Price
IC $^{+.001"}$ $_{-.001"}$	L $^{+.001"}$ $_{-.001"}$	R $^{+.003"}$ $_{-.003"}$			
.464	.471	.015	CPG	CPG-4621	14.30
.464	.471	.031	CPG	CPG-4622	14.30
.500	.508	.015	CPG	CPG-421	12.80
.500	.508	.031	CPG	CPG-422	10.70
.375	-	.031	SPG	SPG-322	12.90
.500	-	.031	SPG	SPG-422	11.40

## Indexable Inserts

TPG / TP / TD

### Indexable Cutters – Generic Inserts – Triangle Style

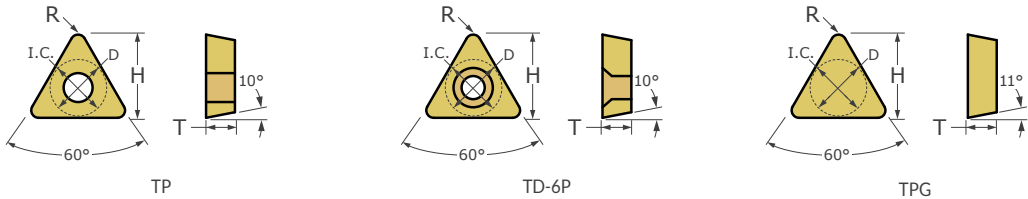

- 60° triangular insert with radius on corner
- For use with clamp locking style holder

Inscribed Circle	Thickness	Height	Radius	Hole Diameter	Set Screw UN	Style	Triangle Style Insert	
							Tool #	Price
IC $^{+.001"}$ $_{-.001"}$	T $^{+.005"}$ $_{-.005"}$	H	R $^{+.003"}$ $_{-.003"}$	D $^{+.003"}$ $_{-.003"}$				
.250	.094	.3438	.031	.137	4-40	TP	TP-42	12.20
.250	.094	.3600	.015	.137	4-40	TP	TP-41	8.30
.250	.125	.3440	.031			TPG	TPG-222	8.80
.375	.125	.5324	.031			TPG	TPG-322	10.70
.375	.125	.5324	.031	.163	6-32	TP	TP-62	14.20
.375	.125	.5324	.031	.125	4-40	TD	TD-6P-2	14.20
.375	.125	.5479	.015			TPG	TPG-321	10.00
.375	.125	.5479	.015	.163	6-32	TP	TP-61	14.20
.375	.125	.5480	.015	.125	4-40	TD	TD-6P-1	14.20
.500	.188	.7030	.047			TPG	TPG-433	16.50
.500	.188	.7199	.031			TPG	TPG-432	12.00

## Accessories

### Indexable Accessories

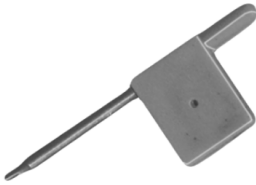
Accessory Type	Compatibility	Description	Accessory	
			Tool #	Price
	Inserts 50-1100 50-1200 50-1300 50-2100	Torx Screw M2.5 x T-8	16-1020	3.80
	Inserts 50-1105	Torx Screw M3.5 x T-15	16-1030	4.40
	Screw 16-1020	Torx Key M2.5 x TK-8	16-1060	3.50
	Screw 16-1030	Torx Key M3.5 x TK-15	16-1070	4.15

Accessories

# Coatings Chart

Coating/ Substrate:	TiN  Titanium Nitride -G	AlTiN  Aluminum Titanium Nitride -X	nACRo®  Aluminum Chromium Nitride Silicone -K	ZrN  Zirconium Nitride -S
Application/ Benefits:	<ul style="list-style-type: none"> <li>General purpose coating with proven performance and increasing tool productivity with higher feeds and speeds in machining of ferrous materials and in applications that are not generating excessive/ extreme heat</li> </ul>	<ul style="list-style-type: none"> <li>Maintains high surface hardness at elevated temperatures, promotes tool life and allows for faster feeds and speeds</li> <li>Higher breakdown temperatures</li> <li>High Performance and versatile coating</li> <li>Excellent for dry-machining</li> </ul>	<ul style="list-style-type: none"> <li>Extremely heat and scratch resistant coating that provides exceptional performance for those "tough and difficult" materials where temperatures increase dramatically during the machining application</li> </ul>	<ul style="list-style-type: none"> <li>Better tool performance over uncoated carbide in numerous non-ferrous materials</li> <li>Characteristics include a high hardness with lubricity and abrasion resistance</li> <li>Generally, an alternative to diamond coatings</li> </ul>
Materials:	General purpose, ferrous and non-ferrous materials	Alloy steels, stainless steels, tool steels, titanium, inconel, nickel and other aerospace materials	Aluminum Alloy Steels, Carbon Steels, Stainless Steels, Hardened Steels, Nickel Alloys, Cast Irons, Titanium and other High Temperature Alloys	Abrasive non-ferrous alloys such as Brass, Bronze, Copper and Abrasive Aluminum Alloys
Color:	Gold	Dark Gray / Black	Black / Gray	Light Gold / Champagne
Structure:	Mono-layer	Multi-layer	Nano-composite	Mono-layer
Hardness (HV 0.05):	2170 (21 GPa)	3569 (35 GPa)	4079(40 GPa)	2460 (24 GPa)
Coefficient of Friction:	.50	.60	0.45	.50
Coating Thickness (microns):	2 - 5	2 - 5	1 - 7	2 - 5
Max. Working Temp:	1000° F	1400° F	2012° F	1100° F

PLEASE NOTE: Information and test results were compiled from multiple sources and testing methods. Data presented is intended to be a general application guideline for comparing various coatings.



**"THE ORIGINAL"**  
**SPEEDY SHARP**  
World's Fastest Sharpener®

Utilizing the same strong, durable carbide as Micro 100 cutting tools, the Speedy Sharp sharpens everything from pocket knives to lawn mower blades with ease.

**Quickly & Effectively Sharpens**

- Knives
- Scissors
- Axes
- Hunting Knives
- Gardening Tools
- Lawn Mower Blades
- Razor Blades
- Chisels
- Planer Blades
- Router Bits
- Fish Hooks

TOOL # KS-1

Add a Speedy Sharp (KS-1) to your tooling order today for only \$11.95!

Learn more at [speedysharp.com](http://speedysharp.com)